

TOSHIBA BI-CMOS INTEGRATED CIRCUITS SILICON MONOLITHIC

TB62713N, TB62713F**7×5 DOT DISPLAY DECODER AND DRIVER
(COMMON CATHODE ROW CAPABILITY)**

The TB62713N and TB62713F are multifunctional, compact, 7×5 dot matrix LED display drivers.

Each of these ICs can directly drive and control one 7×5 dot matrix LED display.

The display shows the common cathode rows.

Row output uses a constant current, which is set using an external resistor.

The column output is standard PNP output.

A synchronous serial port connects the IC to the CPU.

The different modes of control provided by this device, including Duty Control Register Set, Digit Set, Decode Set and Standby Set, are all based on every 16-bit of serial data.

FEATURES

- Control circuit power supply voltage
: $V_{DD} = 4.5$ to $5.5V$
- Digit output rating
: $-17V / -350mA$
- Row output rating
: $17V / 50mA$
- Built-in decoder
: Decoding based on ASCII code.
- Digit control function
: Automatically turns on column output OUT-C₀ to OUT-C₄ in sequence.

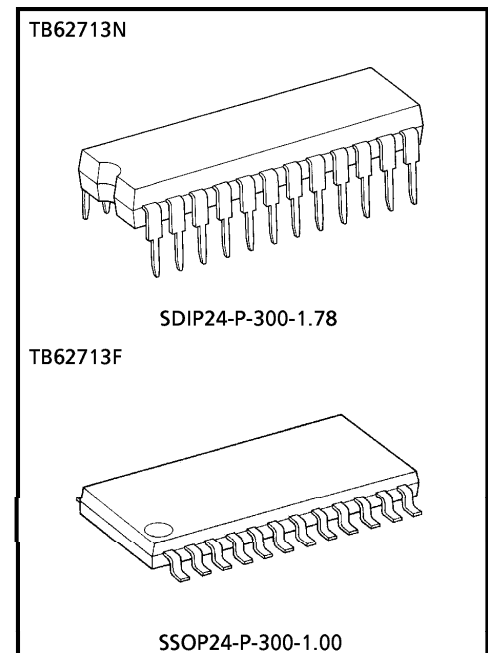

Weight
SDIP24-P-300-1.78 : 1.62g (Typ.)
SSOP24-P-300-1.00 : 0.32g (Typ.)

961001EBA1

- TOSHIBA is continually working to improve the quality and the reliability of its products. Nevertheless, semiconductor devices in general can malfunction or fail due to their inherent electrical sensitivity and vulnerability to physical stress. It is the responsibility of the buyer, when utilizing TOSHIBA products, to observe standards of safety, and to avoid situations in which a malfunction or failure of a TOSHIBA product could cause loss of human life, bodily injury or damage to property. In developing your designs, please ensure that TOSHIBA products are used within specified operating ranges as set forth in the most recent products specifications. Also, please keep in mind the precautions and conditions set forth in the TOSHIBA Semiconductor Reliability Handbook.
- The products described in this document are subject to foreign exchange and foreign trade control laws.
- The information contained herein is presented only as a guide for the applications of our products. No responsibility is assumed by TOSHIBA CORPORATION for any infringements of intellectual property or other rights of the third parties which may result from its use. No license is granted by implication or otherwise under any intellectual property or other rights of TOSHIBA CORPORATION or others.
- The information contained herein is subject to change without notice.

- Maximum transmission frequency (for serial data transmission)
: $f_{CLK} = 15\text{MHz}$
- Row output (OUT-R₀ to OUT-R₆)
Output current can be set to 50mA using an external resistor.
- Constant current tolerance ($T_a = 25^\circ\text{C}$, $V_{DD} = 5.0\text{V}$)
: Variation between bits = $\pm 7\%$, variation between devices (including variation between bits)
= $\pm 15\%$, @ $V_{CE} \geq 0.7\text{V}$
- Package
: 24-pin SDIP (SDIP24-P-300-1.78)
24-pin SSOP (SSOP24-P-300-1.00)

PIN ASSIGNMENT (Top view)

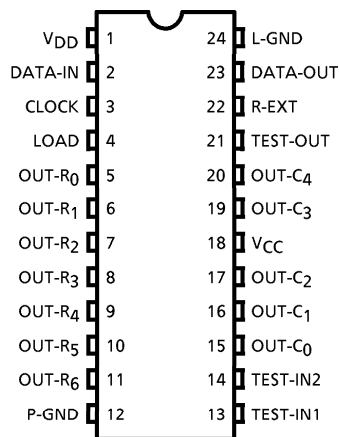

EQUIVALENT CIRCUIT DIAGRAM / BLOCK DIAGRAM

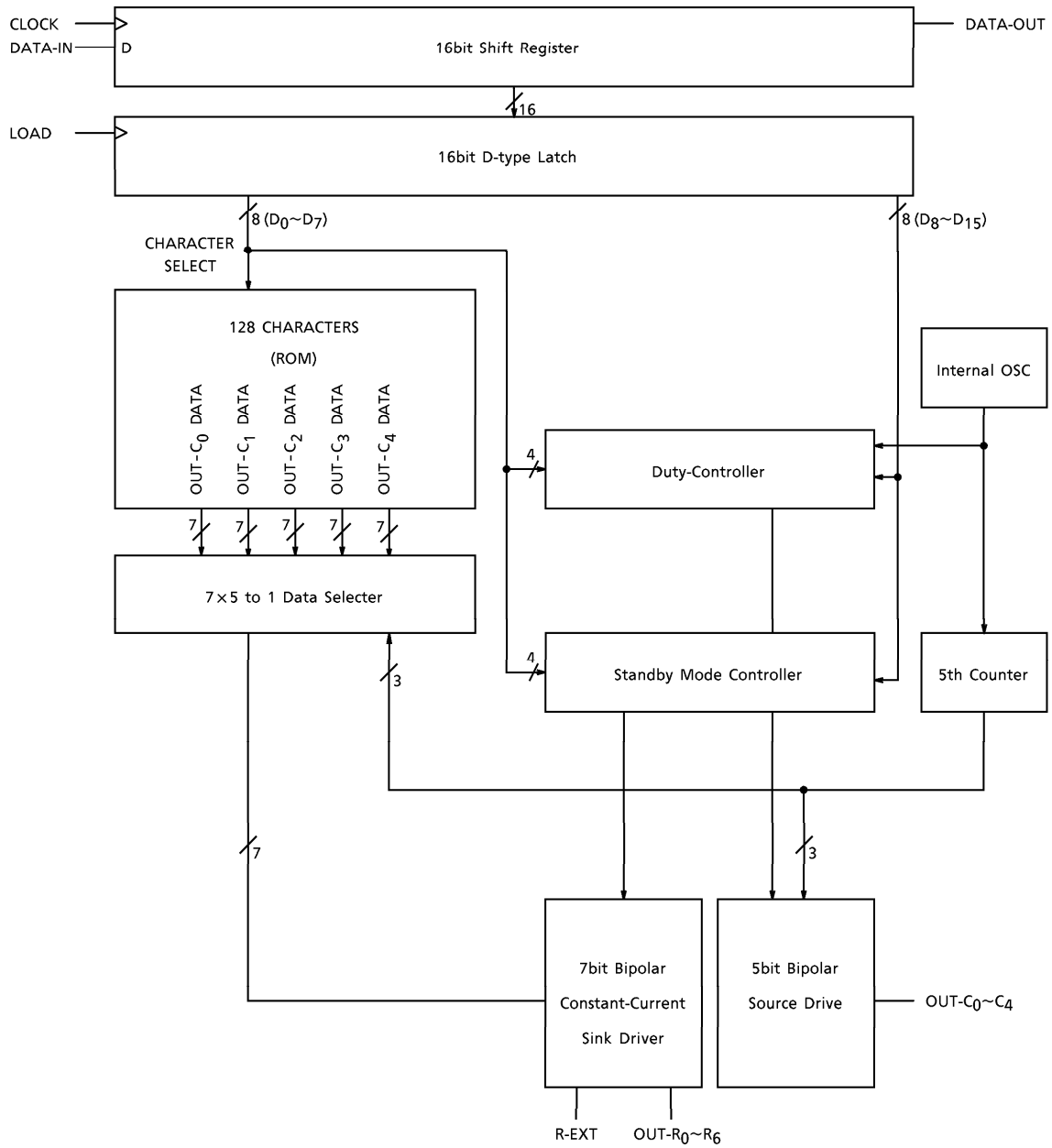

PIN DESCRIPTION

| PIN NUMBER | PIN NAME | FUNCTION |
|-----------------------|--------------------------------------|--|
| 1 | V _{DD} | 5V power pin. |
| 2 | DATA-IN (DI) | Serial data input pin. |
| 3 | CLOCK (CK) | Clock input pin. The shift register shifts data on the clock's rising edge. |
| 4 | LOAD (LD) | Load signal input pin. The data in the D ₈ to D ₁₅ bits of the 16-bit shift register. Are read on the rising edge of the load signal and the current load register is selected from among the Duty Register, the Decode & Digit Register, or Data Registers 0 to 3. The D ₀ to D ₇ bits contain data corresponding to the same registers just described, which are read on the load signal's falling edge. |
| 5~11 | OUT-R ₀ to R ₆ | Row output pins. These pins output constant sink current. Connect these pins to the LED's cathode. |
| 12 | P-GND | Ground pin for row output. |
| 13 | TEST-IN2 | Product test pin. In normal use, be sure to connect to ground. |
| 14 | TEST-IN1 | Product test pin. In normal use, be sure to connect to ground. |
| 15, 16, 17, 19, 20 | OUT-C ₀ to C ₄ | Column output pins. These pins output the V _{CC} pin voltage as a source current output. Connect these pins to the LED common anodes. |
| 18 | V _{CC} | Power pin for column output. |
| 21 | TEST-OUT | Product test pin. In normal use, be sure to leave this pin open. |
| 22 | R-EXT | Current setting pin for the OUT-R ₀ to OUT-R ₆ pins. Connect a resistor between this pin and GND when setting the current. |
| 23 | DATA-OUT (DO) | Serial data output pin. Use this pin when TB62713N or TB62713F devices are cascade-connected. |
| 24 | L-GND | Ground pin for logic and analog circuits. |

TIMING DIAGRAM

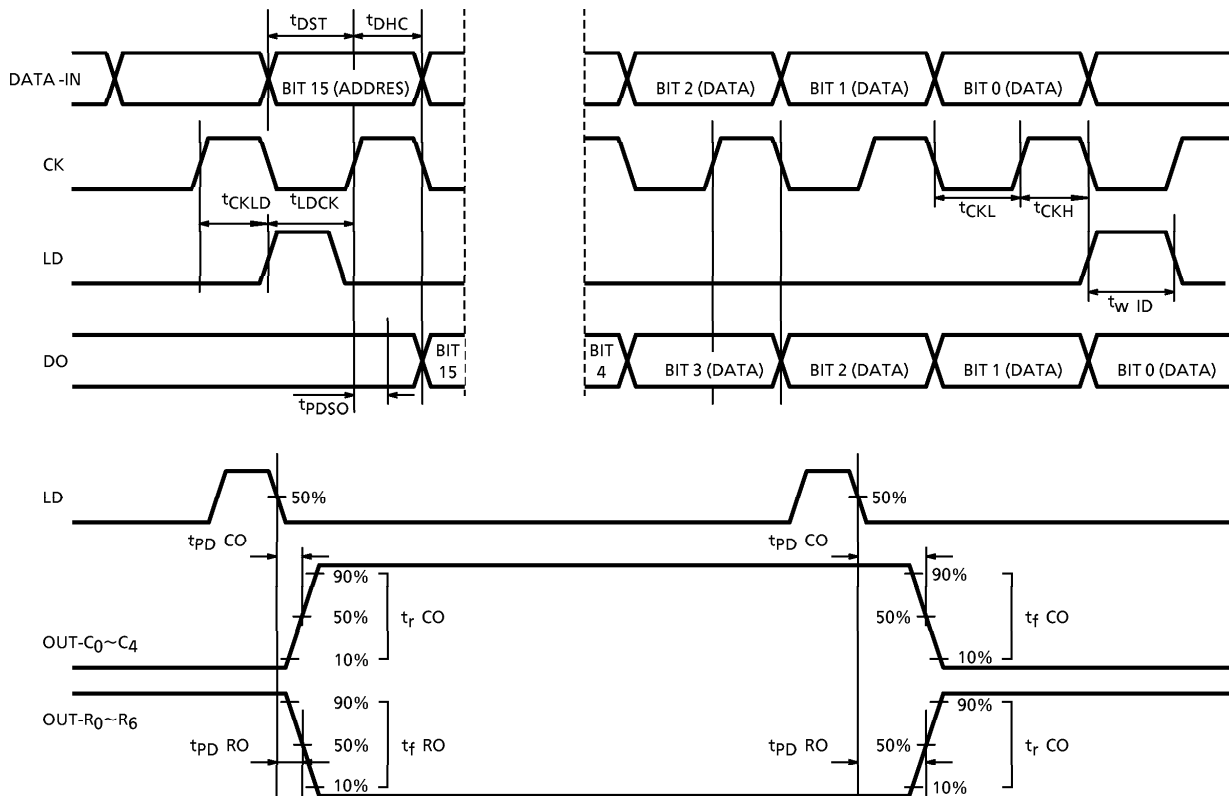

DATA INPUT

- Transfer data to the DATA-IN pin on every 16-bit including address (8bits) and data (8bits). After the 16th clock-signal input following this data transfer, input a load signal from the LD pin.
- Input the load signal using an Active High pulse. The register address is set on the rising edge of the load pulse. On the subsequent falling edge, the data are read as data of the mode of the register.

DESCRIPTION OF OPERATION

- Data input (DATA-IN, CLOCK, LOAD)

The data are input serially using the SERIAL-IN pin. The data input interface consists of a total of three inputs : SERIAL-IN, LOAD, and CLOCK.

Binary code stored in the 16-bit shift register offers control modes including Duty Control Register Set, Digit Set, Decode Set and Standby Set.

The data are shifted, starting from the MSB, on the rising edge of the clock. Cascade-connecting TB62713N or TB62713F devices provides capability for controlling a larger number of digits extensibility.

The serial data in the 16-bit shift register are used as follows : the four bits D₁₅ (MSB) to D₁₂ select the IC operating mode (Table 1), while bits D₁₁ (MSB) to D₈ select the register corresponding to the operating mode (Table 2).

Bits D₇ to D₀ (LSB) are used for detail settings such as number of digits in use, character settings in each digit, and light intensity of these.

The internal registers are loaded on the rising edge of the LOAD signal, which causes loading of data from an external source into the D₁₅ (MSB) to D₈ bits of the shift register, operating mode and the corresponding register selection data. On the subsequent falling edge, the detail setting data of D₇ to D₀ (LSB) are loaded.

Normally LOAD is Low. After a serial transfer of 16bits, the input of a High-level pulse loads the data.

Note the following caution. Use the D₁₅ to D₈ setting and the D₇ to D₀ detail data setting as a pair. If just the D₇ to D₀ data are input without setting D₁₅ to D₈ an error condition may result, in which the device will not operate normally. The register settings will not be normal. If the current mode is set again by a new signal, the data for D₁₅ to D₈ must also be re-input.

- Operating precautions

At power-on or after operation in Clear mode (in initial state), the data are reset. If the IC enters Normal mode after data are input and characters are specified, LEDs are lit according to the input data.

Operating the IC in Blank mode (all lights off) or in All ON mode (all lights lit) does not affect the internal data. Setting the IC to Normal mode again continues the LED lighting in the state governed by the settings made immediately before mode change.

Normal mode (not Shut Down, Clear, Blank, or All On mode) continues the operations set in Load Register mode. In Normal mode, operations are governed by any new settings made in the Load register, as soon as the changed setting values are loaded.

OPERATING MODE SETTINGS

● Operating modes (Table 1)

These ICs support the following five operating modes :

1. Blank : Forcibly turns OFF the constant-current output both for data and digit setting. This mode is not affected by the values in bits D₁₁ to D₀.
2. Normal : Used for display operations after the settings of the digits are complete. This mode is not affected by D₁₁ to D₀. Note that setting this mode without making any other settings results in a blank display (all lights off).
3. Load Register : Used for the detail settings of the Duty Control Register and for inputting display data. D₁₁ to D₀ of the shift register are used for the detail settings of the digits currently being driven. (Table 2).
4. All On : Forcibly turns ON the constant-current data output. This mode is not affected by D₁₁ to D₀.
5. Standby : Used to set Standby state (in which internal data are not cleared) and to clear data (initialization). The settings in D₃ to D₀ determine the choice between standby state or initialization.

Table 1 Operating mode settings

| | REGISTER DATA | | | | | | | | INITIAL SETTING |
|---|-----------------|-----------------|-----------------|-----------------|---------------------------------|--------------------------------|--------------------------------|----------|-----------------|
| | D ₁₅ | D ₁₄ | D ₁₃ | D ₁₂ | D ₁₁ ~D ₈ | D ₇ ~D ₄ | D ₃ ~D ₀ | HEX CODE | |
| BLANK (OUT-n & OUT-R _n ALL-OFF) | 0 | 0 | 0 | 0 | — | — | — | 0---H | ★ |
| NORMAL (OPERATION) | 0 | 0 | 0 | 1 | — | — | — | 1---H | |
| LOAD REGISTER (DUTY & CHARACTER-DATA) | 0 | 0 | 1 | 0 | X | X | X | 2XXXH | |
| ALL ON (OUT-C _n ALL ON) | 0 | 0 | 1 | 1 | — | — | — | 3---H | |
| STANDBY | 0 | 1 | 0 | 0 | — | — | X | 4--XH | |

X = Input H or L. "—" = Are not affected by the truth table.

LOAD REGISTER SELECTION

- Load Register Selection modes (Table 2)

These modes select the register to provide the data to control the IC operation. The Load Register selection mode is determined by the settings of D₁₅ to D₁₂ and D₁₁ to D₈ of the shift register

1. Duty Register : Sets the digit output duty cycle. Duty Settings can be made in 16 steps from 0/16 to 15/16. (Table 3)
2. Data Register : Sets 7×5 display characters. D₇ to D₀ are used to set the display characters.

Table 2 Load register selection

| | REGISTER DATA | | | | | | | HEX CODE |
|------------------------------|----------------------------------|-----------------|-----------------|----------------|----------------|--------------------------------|--------------------------------|----------|
| | D ₁₅ ~D ₁₂ | D ₁₁ | D ₁₀ | D ₉ | D ₈ | D ₇ ~D ₄ | D ₃ ~D ₀ | |
| LOAD DUTY REGISTER | 2H | 0 | 0 | 0 | 0 | X | X | 20XXH |
| LOAD CHARACTER-DATA REGISTER | 2H | 0 | 0 | 0 | 1 | X | X | 21XXH |

X = Input H or L.

DUTY CONTROL REGISTER SETTINGS

- Duty Control Register detail settings and operation (Table 3)

Writing 20H to D₁₅~D₈ and writing 0~FH to D₃~D₀ sets the duty cycle shown in the following table for the digit-side source driver output. The duty cycle can be set in 16 steps.

The initial setting is 15/16. After Data Clear, the setting is also 15/16.

The current settings remain in force until changed (to the initial state, Data Clear state, standby state, or by reset execution).

Table 3 Duty control register settings

| DUTY CYCLE | REGISTER DATA | | | | | | | INITIAL SETTING |
|------------|---------------------------------|--------------------------------|----------------|----------------|----------------|----------------|----------|-----------------|
| | D ₁₅ ~D ₈ | D ₇ ~D ₄ | D ₃ | D ₂ | D ₁ | D ₀ | HEX CODE | |
| 0 / 16 | 20H | — | 0 | 0 | 0 | 0 | 20X0H | |
| 1 / 16 | 20H | — | 0 | 0 | 0 | 1 | 20X1H | |
| 2 / 16 | 20H | — | 0 | 0 | 1 | 0 | 20X2H | |
| 3 / 16 | 20H | — | 0 | 0 | 1 | 1 | 20X3H | |
| 4 / 16 | 20H | — | 0 | 1 | 0 | 0 | 20X4H | |
| 5 / 16 | 20H | — | 0 | 1 | 0 | 1 | 20X5H | |
| 6 / 16 | 20H | — | 0 | 1 | 1 | 0 | 20X6H | |
| 7 / 16 | 20H | — | 0 | 1 | 1 | 1 | 20X7H | |
| 8 / 16 | 20H | — | 1 | 0 | 0 | 0 | 20X8H | |
| 9 / 16 | 20H | — | 1 | 0 | 0 | 1 | 20X9H | |
| 10 / 16 | 20H | — | 1 | 0 | 1 | 0 | 20XAH | |
| 11 / 16 | 20H | — | 1 | 0 | 1 | 1 | 20XBH | |
| 12 / 16 | 20H | — | 1 | 1 | 0 | 0 | 20XCH | |
| 13 / 16 | 20H | — | 1 | 1 | 0 | 1 | 20XDH | |
| 14 / 16 | 20H | — | 1 | 1 | 1 | 0 | 20XEH | |
| 15 / 16 | 20H | — | 1 | 1 | 1 | 1 | 20XFH | ★ |

X=Input H or L. "—" = Are not affected by the truth table.

STANDBY MODE SETTINGS

- Standby mode settings and operation (Table 4)

Writing 4H to D₁₅~D₈ and writing 0001 to D₃~D₀ sets Standby mode. Writing 4H to D₁₅~D₈ and writing 0001 to D₃-D₀ sets All Data Clear mode.

Standby mode maintains the settings made immediately before this mode came in force, turns the output current OFF, and controls the bias current the internal circuits. Resets all settings to their initial states.

Table 7 Standby mode settings

| | REGISTER DATA | | | | | | HEX CODE |
|-------------------------|---------------------------------|--------------------------------|----------------|----------------|----------------|----------------|----------|
| | D ₁₅ ~D ₈ | D ₇ ~D ₄ | D ₃ | D ₂ | D ₁ | D ₀ | |
| STANDBY (NO DATA CLEAR) | 4-H | — | 0 | 0 | 0 | 0 | 4XX0H |
| ALL DATA CLEAR | 4-H | — | 0 | 0 | 0 | 1 | 4XX1H |

X=Input H or L. "—" = Are not affected by the truth table.

Table 6.2 List of ASCII character set decoding data

| | | D0 | 0 | 1 | 0 | 1 | 0 | 1 | 0 | 1 | 0 | 1 | 0 | 1 | 0 | 1 | 0 | 1 | 0 | 1 | 0 | 1 | 0 | 1 | 0 | 1 | |
|----|--------------|-----|----------------|---|---|---|---|---|---|---|---|---|---|---|---|---|---|---|---|---|---|---|---|---|---|---|---|
| | | D1 | 0 | 0 | 1 | 1 | 0 | 0 | 1 | 1 | 0 | 0 | 1 | 1 | 0 | 0 | 1 | 1 | 0 | 0 | 1 | 1 | 0 | 0 | 1 | 1 | 0 |
| | | D2 | 0 | 0 | 0 | 0 | 1 | 1 | 1 | 1 | 0 | 0 | 0 | 1 | 1 | 1 | 0 | 0 | 1 | 1 | 1 | 0 | 0 | 1 | 1 | 0 | 0 |
| | | D3 | 0 | 0 | 0 | 0 | 0 | 0 | 0 | 0 | 1 | 1 | 1 | 1 | 1 | 1 | 1 | 1 | 1 | 1 | 1 | 1 | 1 | 1 | 1 | 1 | 1 |
| D7 | D6 D5 D4 | HEX | 0 | 1 | 2 | 3 | 4 | 5 | 6 | 7 | 8 | 9 | A | B | C | D | E | F | | | | | | | | | |
| 0 | 0 0 0 0 | 0 | See Table 6.1. | | | | | | | | | | | | | | | | | | | | | | | | |
| 0 | 0 0 0 1 | 1 | | | | | | | | | | | | | | | | | | | | | | | | | |
| 0 | 0 0 1 0 | 2 | | | | | | | | | | | | | | | | | | | | | | | | | |
| 0 | 0 0 1 1 | 3 | | | | | | | | | | | | | | | | | | | | | | | | | |
| 0 | 0 1 0 0 | 4 | | | | | | | | | | | | | | | | | | | | | | | | | |
| 0 | 0 1 0 1 | 5 | | | | | | | | | | | | | | | | | | | | | | | | | |
| 0 | 0 1 1 0 | 6 | | | | | | | | | | | | | | | | | | | | | | | | | |
| 0 | 0 1 1 1 | 7 | | | | | | | | | | | | | | | | | | | | | | | | | |

DATA INPUT (Example 1 : Displays A to G, blinks F and G, and adjusts luminance.)

| STEP | D ₁₅ ~D ₁₂ | D ₁₁ ~D ₈ | D ₇ ~D ₄ | D ₃ ~D ₀ | OUT-R ₀ ~R ₆ | OUT-C ₀ ~C ₄ | MODE | DISPLAY INFORMATION |
|------|-------------------------------------|------------------------------------|-----------------------------------|-----------------------------------|------------------------------------|------------------------------------|-------------------------------|---------------------|
| 0 | — | — | — | — | OFF | OFF | At power-on (= CLEAR MODE) | ALL BLANK |
| 1 | 0010 | 0000 | XXXX | 1111 | OFF | OFF | DUTY = 15 / 16 | ALL BLANK |
| 2 | 0010 | 0001 | 0100 | 0001 | OFF | OFF | CHARACTER-DATA = A | ALL BLANK |
| 3 | 0001 | XXXX | XXXX | XXXX | OFF | ON | NORMAL | A |
| 4 | 0010 | 0001 | 0100 | 0010 | ON | ON | CHARACTER-DATA = B | B |
| 5 | 0010 | 0001 | 0100 | 0011 | ON | ON | CHARACTER-DATA = C | C |
| 6 | 0010 | 0001 | 0100 | 0100 | ON | ON | CHARACTER-DATA = D | D |
| 7 | 0010 | 0001 | 0100 | 0101 | ON | ON | CHARACTER-DATA = E | E |
| 8 | 0010 | 0000 | 0100 | 0110 | ON | ON | CHARACTER-DATA = F | F |
| 9 | 0000 | XXXX | XXXX | XXXX | OFF | OFF | BLANK | ALL BLANK |
| 10 | 0010 | 0000 | XXXX | 1000 | OFF | OFF | DUTY = 8 / 16 | ALL BLANK |
| 11 | 0001 | XXXX | XXXX | XXXX | ON | ON | NORMAL | F (MIDDLE BLIGHT) |
| 11 | 0000 | XXXX | XXXX | XXXX | OFF | OFF | BLANK | ALL BLANK |
| 12 | 0010 | 0000 | 0100 | 0111 | ON | OFF | CHARACTER-DATA = G | ALL BLANK |
| 13 | 0001 | XXXX | XXXX | XXXX | ON | ON | NORMAL | G (MIDDLE BLIGHT) |
| 15 | 0100 | XXXX | XXXX | 0000 | OFF | OFF | STANDBY (SHUT DOWN) | ALL BLANK |

STATE TRANSITION DIAGRAM

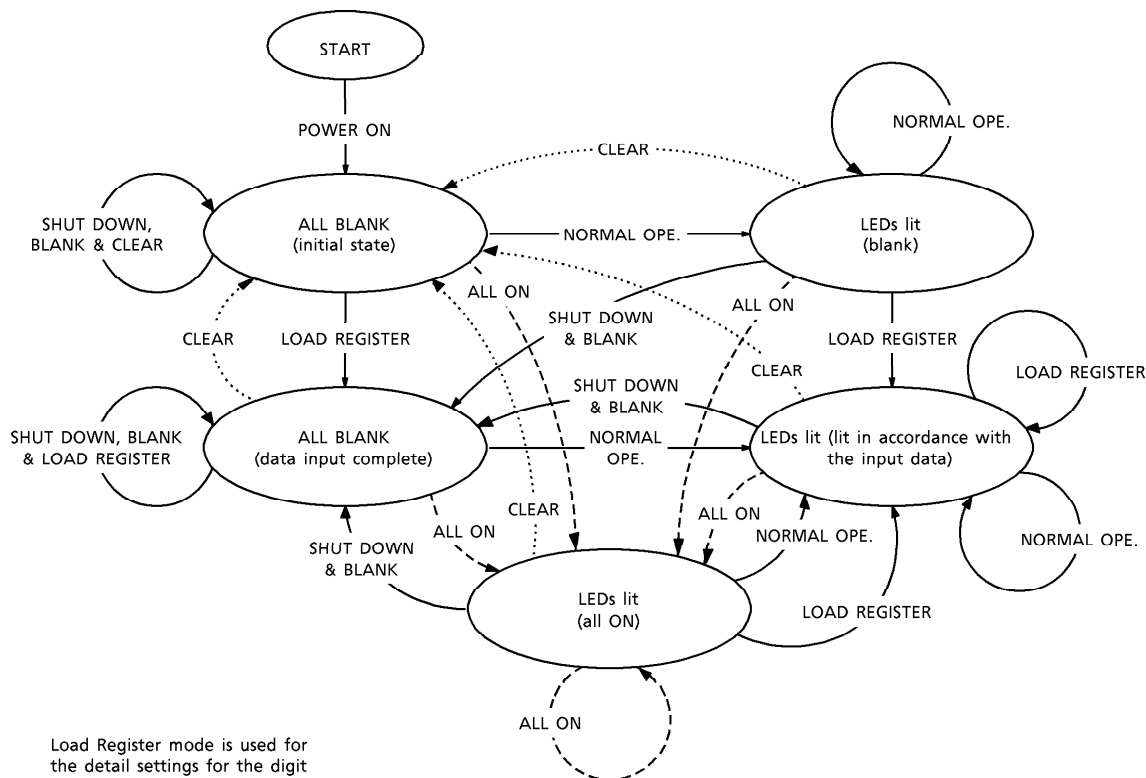

Load Register mode is used for the detail settings for the digit output duty cycle, and for inputting display data.

MAXIMUM RATINGS (Ta = 25°C)

| CHARACTERISTIC | SYMBOL | RATING | UNIT | |
|---|----------------------------------|-----------------------------|------|---|
| Supply Voltage for Logic Circuits | V _{DD} | 7.0 | V | |
| Supply Voltage | V _{CC} | 17 | V | |
| OUT-C ₀ to OUT-C ₃ Output Current | I _{CO} | - 420 | mA | |
| OUT-R ₀ to OUT-R ₆ Output Current | I _{RO} | 60 | mA | |
| Output Current for Logic Block | I _{OH} /I _{OL} | ± 5 | mA | |
| Input Voltage | V _{IN} | - 0.3~V _{DD} + 0.3 | V | |
| Operating Frequency | f _{CK} | 15.0 | MHz | |
| Total Supply Current | I _{VDD} | 420 | mA | |
| Power Dissipation | TB62713N | P _D | 1.78 | W |
| | TB62713F | | 0.62 | |
| Operating Temperature | T _{opr} | - 40~85 | °C | |
| Storage Temperature | T _{stg} | - 55~150 | °C | |

ELECTRICAL CHARACTERISTICS

(Unless otherwise stated, V_{DD} = 5.0V, V_{CC} = 5.0V, R_{EXT} = 580Ω, Ta = - 40 to 85°C)

| CHARACTERISTIC | SYMBOL | TEST CIR-CUIT | TEST CONDITION | MIN. | TYP. | MAX. | UNIT |
|--|--------------------|---------------|--|------|------|------|------|
| Perating Power Supply Current for Output Block | I _{CC1} | 1 | SET NORMAL OPE. MODE, R _{EXT} = 590Ω @OUT-R ₀ ~R ₆ ALL ON, Ta = 25°C | — | 370 | — | mA |
| | I _{CC2} | 1 | SET NORMAL OPE. MODE, R _{EXT} = 590Ω @OUT-R ₀ ~R ₆ ALL ON, V _{CC} = 12V, Ta = 25°C | — | 390 | — | |
| OUT-C ₀ to OUT-C ₄ Scan Frequency | f _{OSC} | 2 | NORMAL OPE. MODE, V _{DD} = 4.5~5.5V | 300 | 600 | 1200 | Hz |
| OUT-R ₀ to OUT-R ₆ Output Sink Current | I _{RO} | 3 | NORMAL OPE. MODE, V _{CE} = 0.7V, R _{EXT} = 590Ω | 36.5 | 43.0 | 49.4 | mA |
| OUT-C ₀ to C ₄ Output Leakage Current | I _{leak1} | 4 | ALL OFF MODE, V _{CC} = 17V | — | — | - 20 | μA |
| OUT-R ₀ to R ₆ Output Leakage Current | I _{leak2} | 4 | ALL OFF MODE, V _{CC} = 17V | — | — | 20 | μA |
| OUT-C ₀ to C ₄ Output Voltage | V _{OUT} | 5 | NORMAL OPE. MODE, I _{OUT-C_n} = - 350mA | 3.0 | — | — | V |

Logic block

| CHARACTERISTIC | SYMBOL | TEST CIR-CUIT | TEST CONDITION | MIN. | TYP. | MAX. | UNIT |
|---|------------------|---------------|---|------|-----------------|------|------|
| Static Power Supply Current for Logic Circuits | I _{DD1} | 6 | STANDBY MODE, Ta = 25°C | — | — | 200 | μA |
| | I _{DD2} | 6 | BLANK MODE, Ta = 25°C | — | — | 12.5 | mA |
| Operating Power Supply Current for Logic Circuits | I _{DD3} | 6 | NORMAL OPE. MODE, f _{CLK} = 10MHz, DATA-IN : OUT-R ₀ ~R ₆ = ON, Ta = 25°C | — | — | 20.5 | mA |
| High Input Current for Logic Circuits | I _{IH} | — | DATA-IN, LOAD & CLOCK : V _{IN} = 5V | — | — | 1 | μA |
| Low Input Current for Logic Circuits | I _{IL} | — | DATA-IN, LOAD & CLOCK : V _{IN} = 0V | — | — | -1 | μA |
| High Output Voltage for Logic Circuits | V _{OH1} | 6 | DATA-OUT, I _{OH} = -1.0mA | 4.6 | — | — | V |
| | V _{OH2} | 6 | DATA-OUT, I _{OH} = -1.0μA | — | V _{DD} | — | |
| Low Output Voltage for Logic Circuits | V _{OL1} | 6 | DATA-OUT, I _{OL} = 1.0mA | — | — | 0.4 | V |
| | V _{OL2} | 6 | DATA-OUT, I _{OH} = 1.0μA | — | 0.1 | — | |
| Clock Frequency | f _{CLK} | 6 | CASCADE CONNECTED, Ta = -40~85°C | 10 | — | — | MHz |

SWITCHING CHARACTERISTICS (Unless otherwise stated, $V_{DD} = 5.0V$, $V_{CC} = 5.0V$, $T_a = 25^\circ C$)

| CHARACTERISTIC | SYMBOL | TEST CIR-CUIT | TEST CONDITION | MIN. | TYP. | MAX. | UNIT |
|---|--------------|---------------|----------------|------|------|------|---------|
| Data Hold Time (D-IN-CLOCK) | t_{DHO} | — | — | — | 10 | — | ns |
| Data Setup Time (D-IN-CLOCK) | t_{DST} | — | — | — | 20 | — | ns |
| Serial Output Delay Time (CLOCK-D-OUT) | t_{PDSO} | — | $C_L = 10pF$ | — | 25 | — | ns |
| High Clock Pulse Width | t_{CKH} | — | — | — | 30 | — | ns |
| Low Clock Pulse Width | t_{CKL} | — | — | — | 30 | — | ns |
| Load Pulse Width | t_{wLD} | — | — | — | 100 | — | ns |
| Load Clock Time (CLOCK-LOAD) | t_{CLK-LD} | — | — | — | 50 | — | ns |
| Clock Load Time (LOAD-CLOCK) | t_{LD-CLK} | — | — | — | 50 | — | ns |
| OUT-C ₀ to OUT-C ₆ Output Delay Time (LOAD-OUT-C _n) | $t_{pD CO}$ | — | $C_L = 10pF$ | — | — | 5.0 | μs |
| OUT-C ₀ to OUT-C ₆ Output Rise Time (OUT-C _n) | $t_r CO$ | — | $C_L = 10pF$ | 0.2 | 1.0 | — | μs |
| OUT-C ₀ to OUT-C ₆ Output Fall Time (OUT-C _n) | $t_f CO$ | — | $C_L = 10pF$ | 0.2 | 1.0 | — | μs |
| OUT-R ₀ to OUT-R ₄ Output Delay Time (LOAD-OUT-R _n) | $t_{pD RO}$ | — | $C_L = 10pF$ | — | — | 10.0 | μs |
| OUT-R ₀ to OUT-R ₄ Output Rise Time (OUT-R _n) | $t_r RO$ | — | $C_L = 10pF$ | 0.4 | 2.0 | — | μs |
| OUT-R ₀ to OUT-R ₄ Output Fall Time (OUT-R _n) | $t_f RO$ | — | $C_L = 10pF$ | 0.4 | 2.0 | — | μs |

RECOMMENDED OPERATING CONDITIONS(Unless otherwise stated, $V_{DD} = 5.0V$, $V_{CC} = 5.0V$, $T_a = -40$ to $85^\circ C$)

| CHARACTERISTIC | SYMBOL | TEST CIR-CUIT | TEST CONDITION | MIN. | TYP. | MAX. | UNIT |
|--|----------|---------------|------------------|------|------|------|------|
| Supply Voltage for Output Block | V_{CC} | — | — | 4.0 | — | 15.0 | V |
| OUT-R ₀ to R ₄ Output Source Current | I_{CO} | — | $V_{OUT} = 3.0V$ | — | — | -280 | mA |
| OUT-C ₀ to C ₆ Output Sink Current | I_{RO} | — | $V_{CE} = 0.7V$ | — | — | 50 | mA |

Logic block

| CHARACTERISTIC | SYMBOL | TEST CIR-CUIT | TEST CONDITION | MIN. | TYP. | MAX. | UNIT |
|---------------------------------------|----------|---------------|---|-----------------|------|-----------------|---------|
| Supply Voltage for Logic Block | V_{DD} | — | — | 4.5 | — | 5.5 | V |
| High Input Current for Logic Circuits | I_{IH} | — | DATA-IN, LOAD & CLOCK, $V_{IN} = V_{DD}$ | — | — | 1 | μA |
| Low Input Current for Logic Circuits | I_{IL} | — | DATA-IN, LOAD & CLOCK, $V_{IN} = 0V$ | — | — | -1 | μA |
| High Input Voltage for Logic Circuits | V_{IH} | — | — | 0.7 V_{DD} | — | — | V |
| Low Input Voltage for Logic Circuits | V_{IL} | — | — | — | — | 0.3 V_{DD} | V |

SWITCHING CONDITIONS

| CHARACTERISTIC | SYMBOL | TEST CIR-CUIT | TEST CONDITION | MIN. | TYP. | MAX. | UNIT |
|--|-------------|---------------|----------------|------|------|------|------|
| Data Hold Time (D-IN-CLOCK) | t_{DHO} | — | — | 30 | — | — | ns |
| Data Setup Time (D-IN-CLOCK) | t_{DST} | — | — | 50 | — | — | ns |
| Serial Output Delay Time (CLOCK-D-OUT) | t_{PDSO} | — | $C_L = 10pF$ | 50 | — | — | ns |
| High Clock Pulse Width | t_{CKH} | — | — | 30 | — | — | ns |
| Low Clock Pulse Width | t_{CKL} | — | — | 30 | — | — | ns |
| Load Pulse Width | t_{wLD} | — | — | 150 | — | — | ns |
| Load Clock Time (CLOCK-LOAD) | t_{CLKLD} | — | — | 100 | — | — | ns |
| Clock Load Time (LOAD-CLOCK) | t_{LDCLK} | — | — | 100 | — | — | ns |

TEST CIRCUITS

(1) I_{CC1} , I_{CC2}

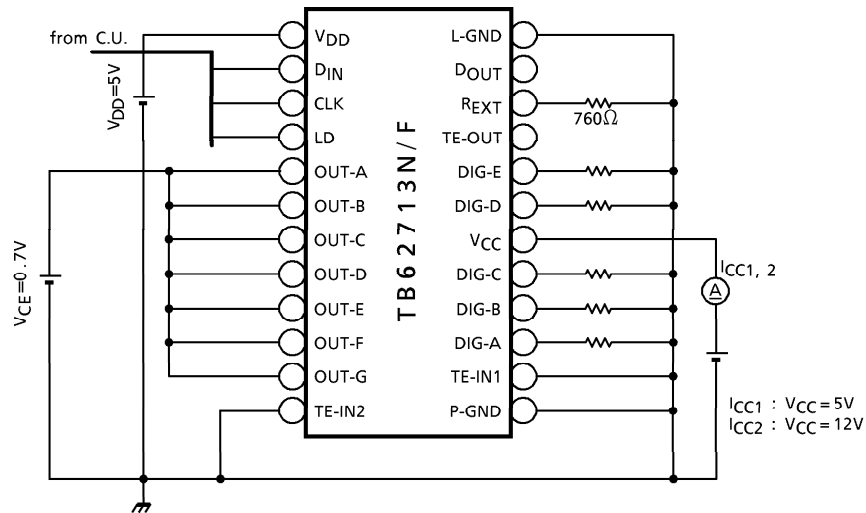

(2) f_{osc}

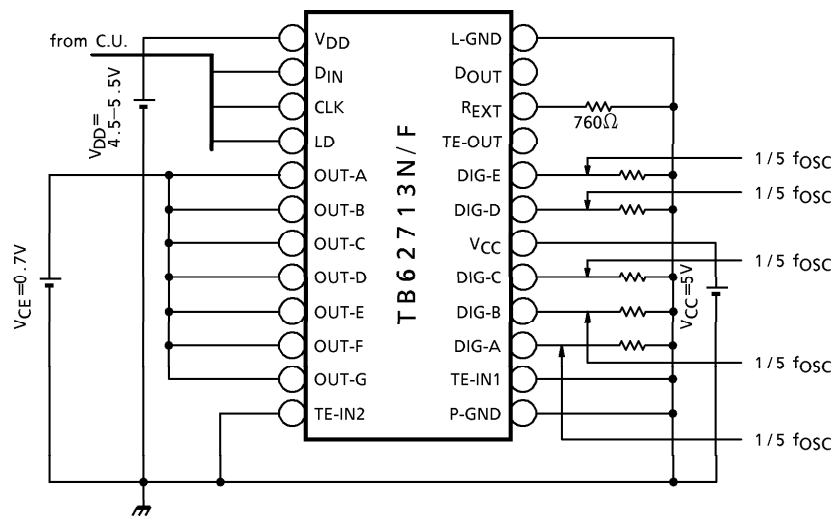

(3) I_{SEG}

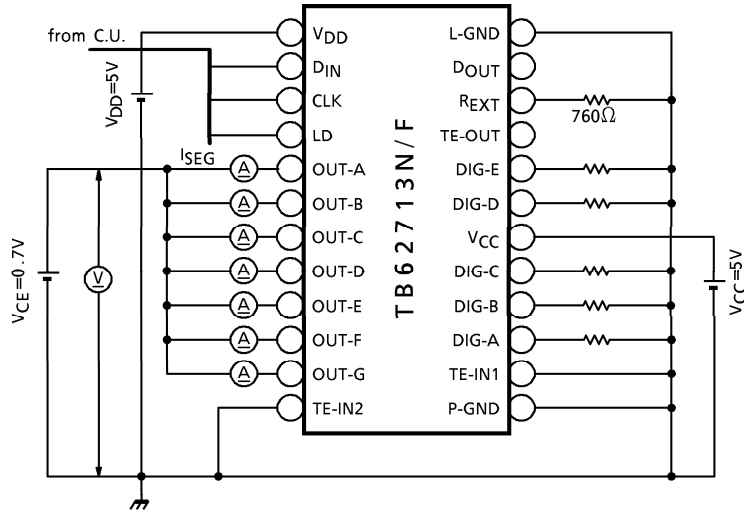

(4) I_{leak1}, I_{leak2}

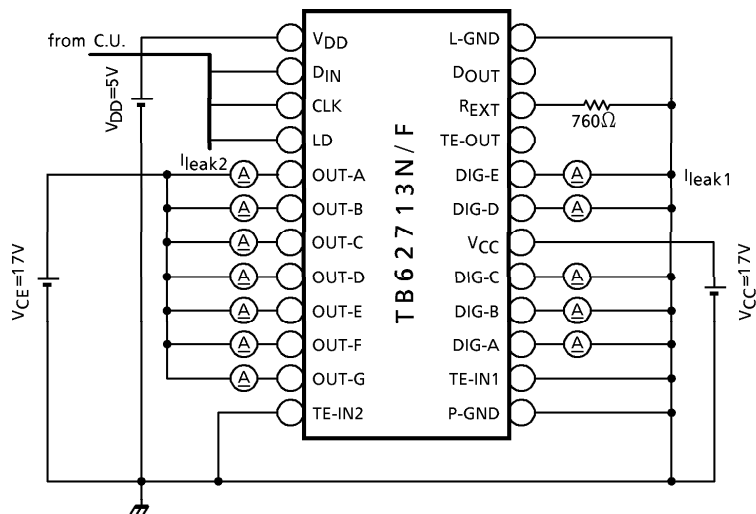

(5) V_{OUT}

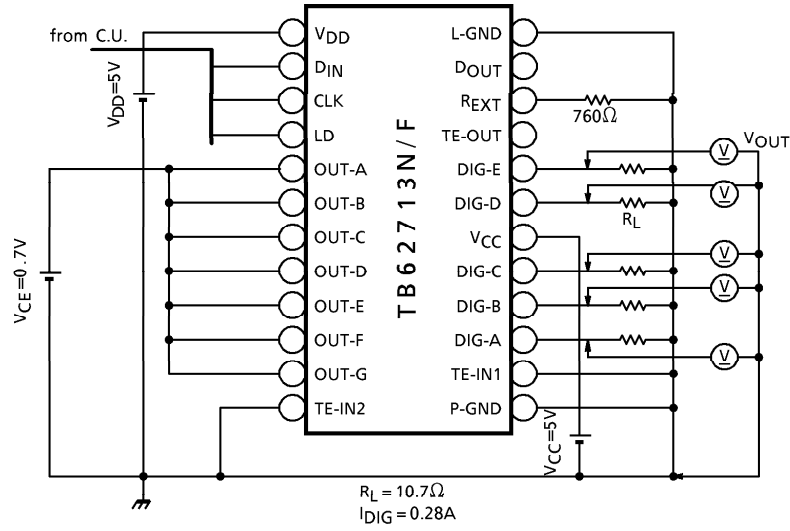

(6) I_{DD1} , I_{DD2} , I_{DD3} , V_{OH1} , V_{OH2} , V_{OL1} , V_{OL2} , f_{CLK}

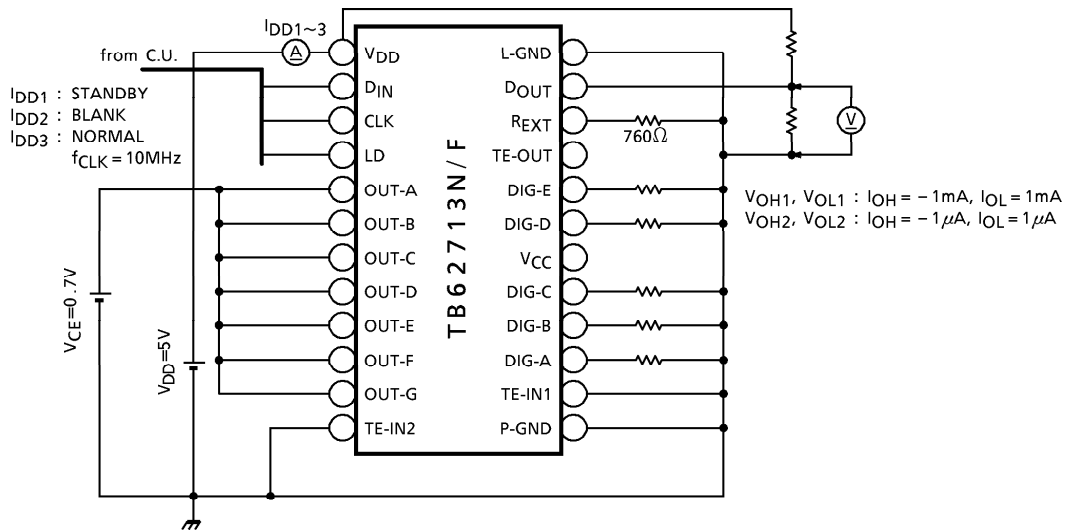

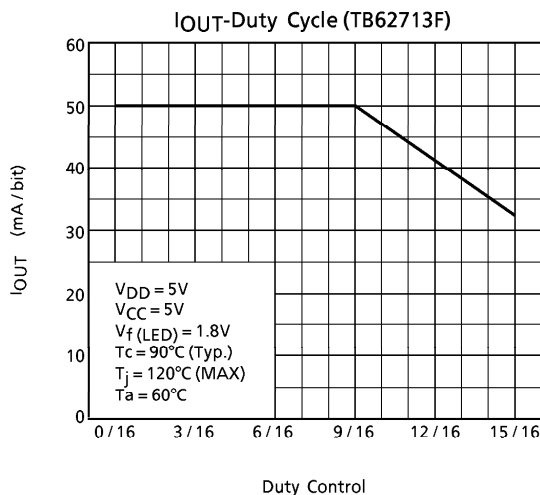
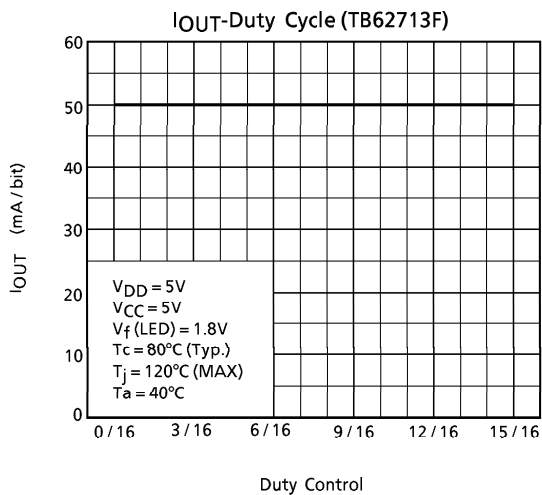
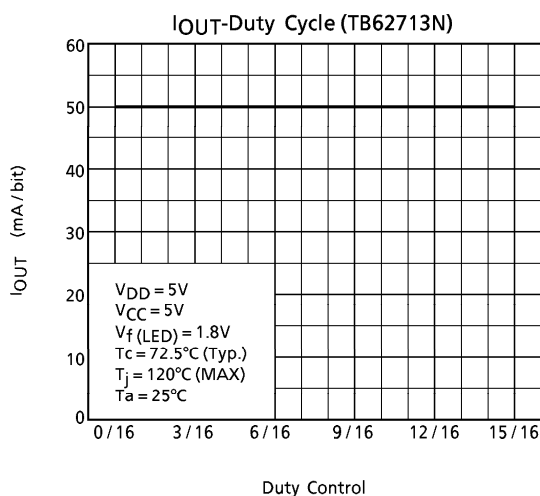
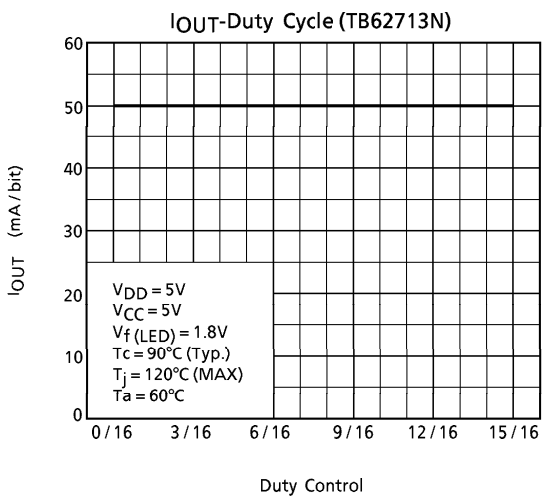

EXTERNAL RESISTANCE AND OUTPUT CURRENT VALUES

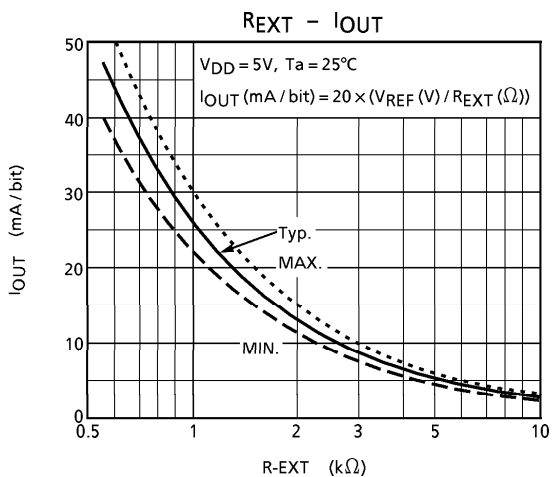

The following diagram shows the application circuit.

Because operation may be unstable due to influences such as the electromagnetic induction of the wiring, the IC should be located as close as possible to the LED.

The L-GND and P-GND of this IC are connected to the substrate in the IC.

Take care to avoid a potential difference exceeding 0.4V at two pins.

When executing the pattern layout, Toshiba recommends not including inductance components in the GND or output pin lines, and not inserting capacitance components exceeding 50pF between the R_{EXT} pin and GND.

APPLICATION CIRCUIT EXAMPLE (Connection example)

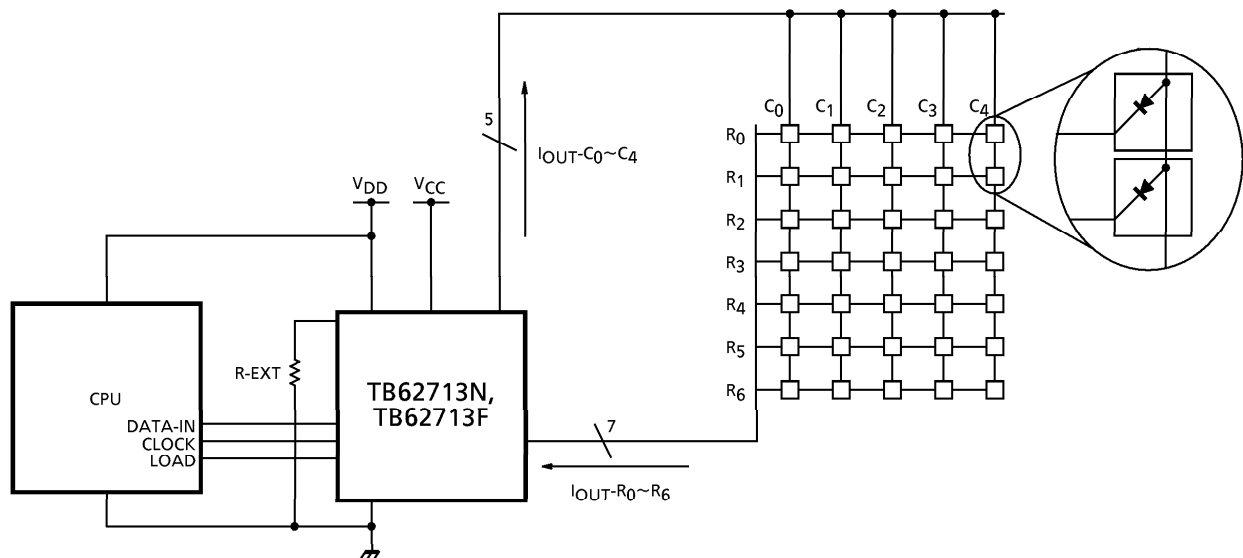

PRECAUTIONS for USING

Utmost care is necessary in the design of the output line, V_{CC} (V_{DD}) and GND (L-GND, P-GND) line since IC may be destroyed due to short-circuit between outputs, air contamination fault, or fault by improper grounding.

OUTLINE DRAWING
SDIP24-P-300-1.78

Unit : mm

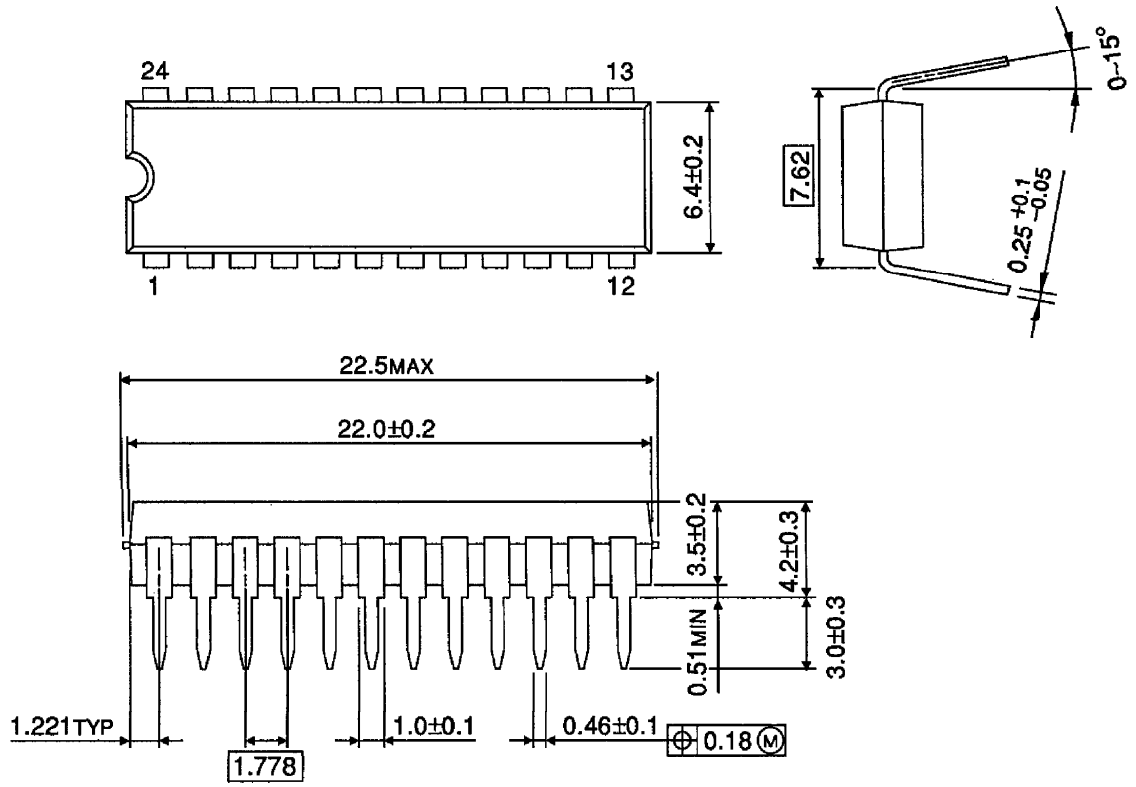

Weight : 1.62g (Typ.)

OUTLINE DRAWING
SSOP24-P-300-1.00

Unit : mm

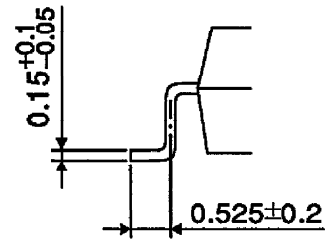
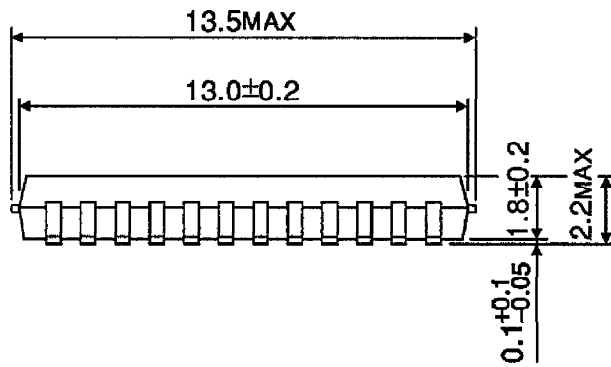
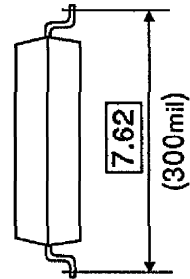
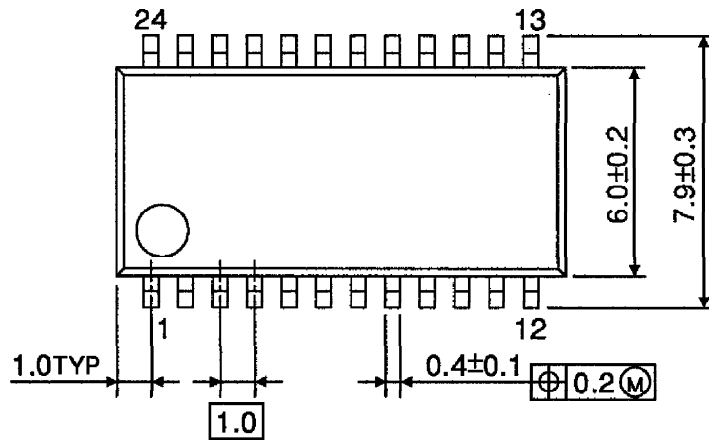

Weight : 0.32g (Typ.)