

TOSHIBA BIPOLAR LINEAR INTEGRATED CIRCUIT SILICON MONOLITHIC

TA8805F,TA1207F

FOR LCD TVS, PIF AND SIF SYSTEM

FEATURES

- PIF circuit
 - High input sensitivity
 - 3-stage variable-gain PIF amplifier
 - Output with black noise inverter (TA8805F)
 - Output without black noise inverter (TA1207F)
 - High-speed response peak AGC with dual time constant
 - Reverse RF AGC output (Emitter follower type)
 - Built-in AFT detection circuit with AFT mute
- SIF circuit
 - 4-stage SIF amplifier
 - Quadrature-type detection circuit
 - Use of a ceramic discriminator device makes the SIF circuit adjustment-free
 - Electronic volume control
 - Built-in audio amplifier (output power : 30 mW (Typ.))

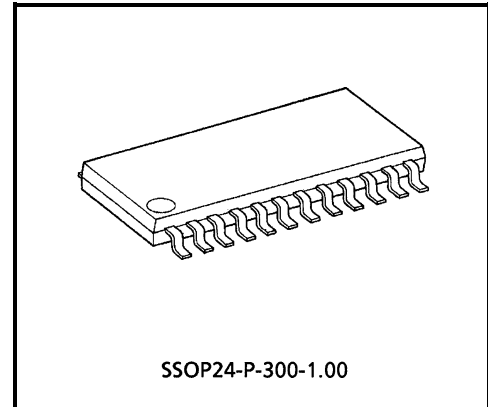

Weight: 0.32 g(Typ.)

000707EBA1

- TOSHIBA is continually working to improve the quality and reliability of its products. Nevertheless, semiconductor devices in general can malfunction or fail due to their inherent electrical sensitivity and vulnerability to physical stress. It is the responsibility of the buyer, when utilizing TOSHIBA products, to comply with the standards of safety in making a safe design for the entire system, and to avoid situations in which a malfunction or failure of such TOSHIBA products could cause loss of human life, bodily injury or damage to property.
In developing your designs, please ensure that TOSHIBA products are used within specified operating ranges as set forth in the most recent TOSHIBA products specifications. Also, please keep in mind the precautions and conditions set forth in the "Handling Guide for Semiconductor Devices," or "TOSHIBA Semiconductor Reliability Handbook" etc..
- The TOSHIBA products listed in this document are intended for usage in general electronics applications (computer, personal equipment, office equipment, measuring equipment, industrial robotics, domestic appliances, etc.). These TOSHIBA products are neither intended nor warranted for usage in equipment that requires extraordinarily high quality and/or reliability or a malfunction or failure of which may cause loss of human life or bodily injury ("Unintended Usage"). Unintended Usage include atomic energy control instruments, airplane or spaceship instruments, transportation instruments, traffic signal instruments, combustion control instruments, medical instruments, all types of safety devices, etc.. Unintended Usage of TOSHIBA products listed in this document shall be made at the customer's own risk.
- The products described in this document are subject to the foreign exchange and foreign trade laws.
- The information contained herein is presented only as a guide for the applications of our products. No responsibility is assumed by TOSHIBA CORPORATION for any infringements of intellectual property or other rights of the third parties which may result from its use. No license is granted by implication or otherwise under any intellectual property or other rights of TOSHIBA CORPORATION or others.
- The information contained herein is subject to change without notice.

BLOCK DIAGRAM (TA8805F)

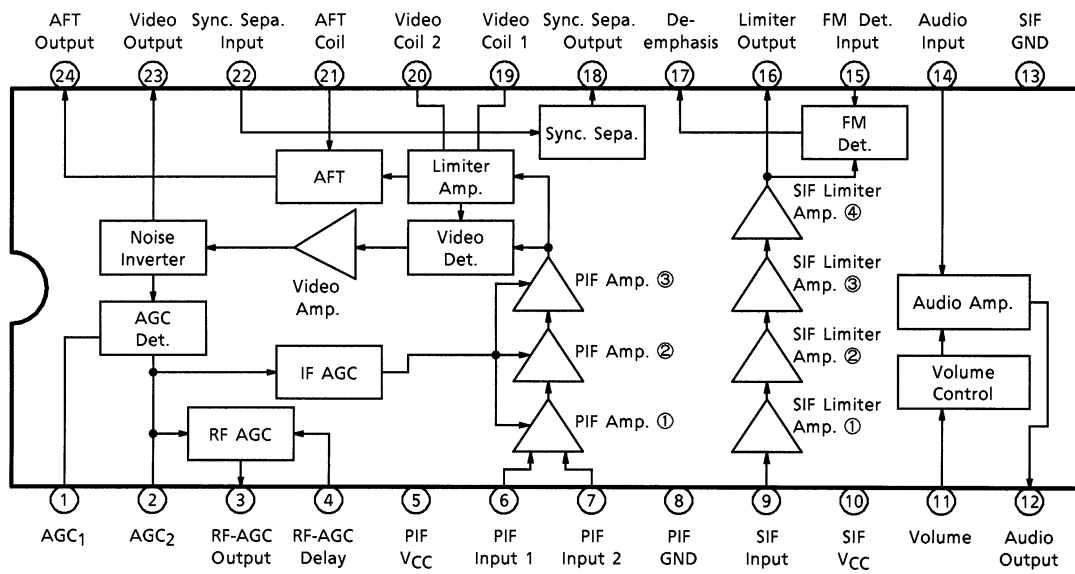

BLOCK DIAGRAM (TA1207F)

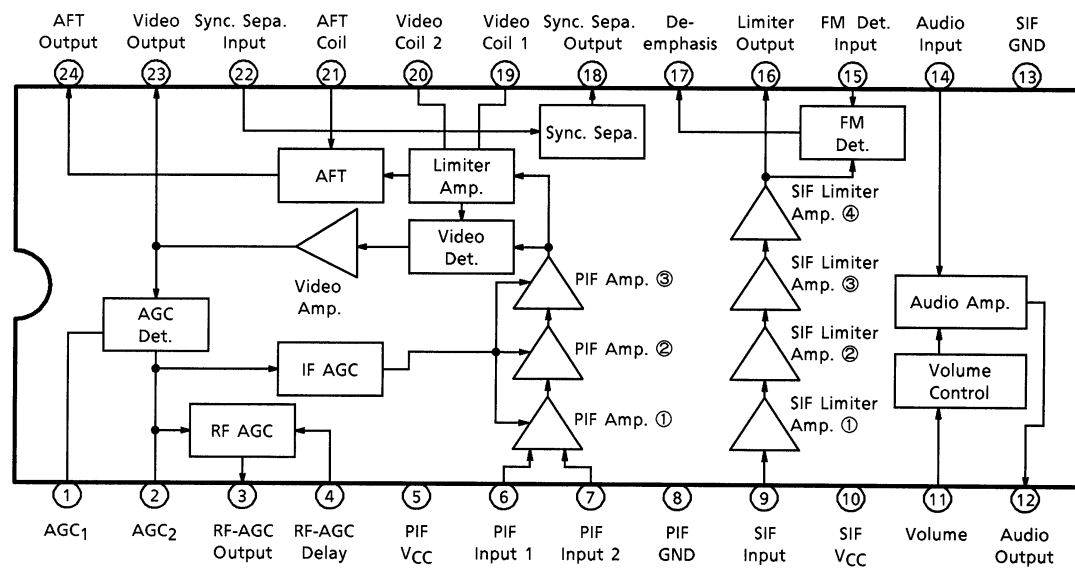

TERMINAL FUNCTION

PIN No.	PIN NAME	FUNCTION	INTERFACE
1 2	PIF AGC ₁ PIF AGC ₂	This IC is adopted dual time constant AGC circuit to improve AGC responsibility. To mute picture, connect to GND	
3	RF AGC Output	RF AGC output terminal. (Emitter follower type) Output current : 3 mA (Typ.)	
4	RF AGC Delay	Changing comparator reference voltage adjusts RF AGC delay point.	
5	PIF V _{CC}	Connect bypass capacitor between this terminal and PIF GND with shortest wiring.	-
6 7	PIF Input 1 PIF Input 2	PIF input terminal. Input impedance 5 kΩ (Typ.)	
8	PIF GND	Connect bypass capacitor between this terminal and PIF V _{CC} with shortest wiring.	-

PIN No.	PIN NAME	FUNCTION	INTERFACE
9	SIF Input	Connect B.P.F. between this terminal and pin 23.	
10	SIF V _{CC}	Connect bypass capacitor between this terminal and SIF GND with shortest wiring.	—
11	Volume	Control audio amp. gain. (Control range 70 dB (Typ.))	
12	Audio Output	Audio signal output terminal. (Output power : 30 mW (Typ.))	
13	SIF GND	Connect bypass capacitor between this terminal and SIF V _{CC} with shortest wiring.	—
14	Audio Input	Audio signal input terminal. Input audio signal from pin 17 through filter	
15	FM Det. Input	Quadrature input terminal for FM detection circuit. Connect FM coil between this terminal and pin 16. Audio output is muted when this terminal is connected to GND.	
17	De-emphasis	Audio signal output terminal.	

PIN No.	PIN NAME	FUNCTION	INTERFACE
16	Limiter Output	Limiter output terminal. Connect FM coil between this terminal and pin 15. Applying ceramic discriminator sets this circuit to non-adjustable circuit.	
18 22	Sync. Sepa.	Sync. sepa. output and input terminal.	
19 20	Video Coil 1 Video Coil 2	Connect video detection coil.	
21	AFT Coil	Connect AFT detection coil. AFT output is defeated when this terminal connected to GND.	
23	Video Output	Video signal output terminal.	
24	AFT Output	AFT detector output terminal based on double balanced multiplier. AFT output is muted when AFT coil terminal is connected to GND.	

MAXIMUM RATINGS (Ta = 25°C)

CHARACTERISTIC	SYMBOL	RATING	UNIT
Power Supply Voltage	V _{CC}	8	V
Power Dissipation	P _D (Note)	500	mW
Operating Temperature	T _{opr}	-20~65	°C
Storage Temperature	T _{stg}	-55~150	°C

Note: When using the device at above Ta = 25°C, decrease the power dissipation by 4 mW for each increase of 1°C.

RECOMMENDED POWER SUPPLY

PIN No.	PIN NAME	MIN	TYP.	MAX	UNIT
5	PIF V _{CC}	3.5	4.5	7.5	V
9	SIF V _{CC}	3.5	4.5	7.5	V

ELECTRIC CHARACTERISTICS (Unless otherwise specified, V_{CC} = 4.5 V, Ta = 25°C)

DC CHARACTERISTICS

PIN No.	PIN NAME	FUNCTION	MIN	TYP.	MAX	UNIT
1	AGC ₁	1st AGC filter	—	4.2	—	V
2	AGC ₂	2nd AGC filter	—	4.2	—	
3	RF AGC	RF AGC output	3.6	3.8	4.0	
4	RF AGC delay	RF AGC delay	—	—	—	
5	PIF V _{CC}	PIF V _{CC}	—	4.5	—	
6	PIF input 1	IF input	2.5	2.9	3.2	
7	PIF input 2	IF input	2.5	2.9	3.2	
8	PIF GND	PIF GND	—	0	—	
9	SIF input	SIF input	4.3	4.45	4.6	
10	SIF V _{CC}	SIF V _{CC}	—	4.5	—	
11	Volume control	Audio volume control	2.0	2.2	2.4	
12	Audio output	Audio output	0.9	1.3	1.7	
13	SIF GND	SIF GND	—	0	—	
14	Audio input	Audio input	—	—	0.5	
15	FM det. Input	FM det. Output	3.5	3.7	3.9	
16	Limiter output	SIF limiter output	2.55	2.75	2.95	
17	De-emphasis	Audio de-emphasis	1.15	1.45	1.75	
18	Sync. sepa. Output	Sync. sepa. signal output	—	—	—	
19	Video coil 1	PIF carrier output	4.05	4.15	4.25	
20	Video coil 2	PIF carrier output	4.05	4.15	4.25	
21	AFT coil	Connecting AFT coil	4.35	4.45	4.55	
22	Sync. sepa. Input	Sync. sepa. signal output	—	—	—	
23	Video output 1	Video signal output	1.40	1.85	2.30	
24	AFT output	AFT output	1.3	1.8	3.2	

AC CHARACTERISTICS (Unless otherwise specified, $V_{CC} = 4.5\text{ V}$, $T_a = 25^\circ\text{C}$) PIF circuit

CHARACTERISTIC	SYMBOL	TEST CIR-CUIT	CONDITION	MIN	TYP.	MAX	UNIT
Power Supply Current at No Signal	I_{PIF}	1	—	—	11	16	mA
Output Signal Voltage	V_D	2	(Note 1)	0.7	1.0	1.3	V_{p-p}
PIF Input Signal Voltage Sensitivity	$V_i \text{ MIN}$	2	(Note 2)	—	43	50	$\text{dB}\mu\text{V}$
Maximum input Signal Voltage	$V_i \text{ MAX}$	2	(Note 3)	95	114	—	$\text{dB}\mu\text{V}$
-3 dB Video Band Width	BW	2	(Note 4)	5	6.5	—	MHz
Dependence of Output Signal Voltage On Power Supply Voltage	V_D / V_{CC}	2	(Note 5)	—	± 5	—	% / V
Deferential Gain	DG	3	(Note 6)	—	5	10	%
Deferential Phase	DP			—	4	8	$^\circ$
Signal-Noise Ratio	S / N	2	(Note 7)	40	45	—	dB
Intermodulation	IM	4	(Note 8)	30	35	—	dB
Suppression of Picture Career	CR	2	(Note 9)	45	50	—	dB
Sync. Voltage Level	V_p	2	87.5%AM, standard color-bar signal	0.6	0.8	1.0	V
Output Voltage at No Signal	V_z	2	(Note 10)	1.6	2.0	2.4	V
Black Noise Inverter Level	V_{BTH}	2	(Note 11) (TA8805F)	0.4	0.6	0.8	V
Black Noise Clamp Level	V_{BCL}			1.0	1.2	1.4	
AFT Control Steepness	$\Delta f / \Delta V$	2	Load : 100 k Ω / 100 k Ω	10	20	30	kHz / V
AFT maximum Output Voltage	V_{MAX}			4.0	4.3	4.5	V
AFT minimum Output Voltage	V_{MIN}			—	0.3	0.5	
AFT Mute Voltage	V_{MUTE}			2.1	2.25	2.4	
PIF Amp. Input Impedance	R_{IN}	2	—	—	5	—	k Ω
	C_{IN}	2	—	—	3.8	—	pF
Video Signal Output Impedance	P_{OUT}	2	—	—	200	—	Ω
Video Amp. Output Impedance	R_{OUT}	2	—	—	200	—	Ω

SIF circuit

CHARACTERISTIC	SYMBOL	TEST CIR-CUIT	CONDITION	MIN	TYP.	MAX	UNIT
Power Supply Current at No Signal	I _{SIF}	1	—	—	6	11	mA
Output Signal Voltage	V _{OD}	2	(Note 12)	120	150	180	mV _{rms}
SIF Input Signal Voltage Sensitivity	V _{LIM}	2	(Note 13)	30	35	40	dB μ V
Total Harmonic Distortion	THD (DET)	2	(Note 14)	—	0.4	1.0	%
AM Rejection	AMR	5	(Note 15)	30	45	—	dB
Signal-Noise Ratio	S / N DET	2	(Note 16)	50	65	—	dB
-3 dB Bandwidth	BW - 3dB	2	(Note 17)	180	230	—	kHz
Dependence of Output Signal Voltage On Power Supply Voltage	V _{OD} / V _{CC}	2	(Note 18)	—	10	15	% / V
Audio Amp. Voltage Gain	G _{AF}	2	(Note 19)	7.0	10.0	13.0	dB
Audio Amp. Total Harmonic Distortion	THD _{AF}	2	(Note 20)	—	0.3	1.0	%
Audio Amp. Maximum Attenuation	ATT _{MAX}	2	(Note 21)	60	70	—	dB
Audio Amp. S / N	S / N _{AF}	2	(Note 22)	40	50	—	dB
Audio Amp. Output Power	P _O	2	(Note 23)	15	30	—	mW

Sync. sepa. circuit

CHARACTERISTIC	SYMBOL	TEST CIR-CUIT	CONDITION	MIN	TYP.	MAX	UNIT
Sync. Sepa. input Voltage	V _{SYNC.IN}	2	—	1.8	2.1	3.0	V
Sync. Sepa. Minimum Output Voltage	V _{SYNC.MIN}	2	Load : 47 k Ω	0	0.2	0.4	V
Sync. Sepa. Maximum Output Voltage	V _{SYNC.MAX}	2		4.3	4.5	—	V

TEST CONDITION

<PIF circuit>

Note 1: Output signal voltage

PIF input : $f_0 = 58.75$ MHz, 87.5%AM, 84 dB μ V, standard TV signal (V / S = 10 : 4 Ramp)

Measure output video signal voltage.

Note 2: PIF input signal voltage sensitivity

PIF input : $f_0 = 58.75$ MHz, $f_m = 15.75$ kHz, 30%AM, 84 dB μ V

Measure output video signal voltage (that voltage is 0 dB). Lower input signal voltage gradually, measure input PIF signal voltage when output video signal voltage is -3 dB.

Note 3: Maximum input signal voltage

PIF input : $f_0 = 58.75$ MHz, $f_m = 15.75$ kHz, 30%AM, 84 dB μ V

Measure output video signal voltage (that voltage is 0 dB). Raise input signal voltage gradually, measure input PIF signal voltage when output video signal voltage is +3 dB

Note 4: -3 dB video band width

(1) PIF input :

$f_0 = 58.75$ MHz, 84 dB μ V, CW

Measure IF AGC voltage and supply that voltage from external source.

(2) Input following composite signals to the PIF input :

SG : 1 58.75 MHz, 84 dB μ V (frequency : fixed)
SG : 2 58.65~45 MHz, 64 dB μ V (frequency : variable)

Monitor spectrum of output signal at pin 24. Change frequency of SG : 2, measure frequency of SG : 2, when video output signal is -3 dB.

Difference between that frequency and 58.75 MHz is -3 dB band width.

Note 5: Dependence of output signal voltage on power supply voltage

PIF input : $f_0 = 58.75$ MHz, 87.5%AM, 84 dB μ V, standard TV signal (V / S = 10 : 4 Ramp)

Measure the output video signal voltage when power supply voltage are 3.5 V and 5.5 V. (4.5 ± 1.0 V)

Compare those voltage and the output video signal voltage when power supply voltage is 4.5 V.

Note 6: Deferential gain / Deferential phase

PIF input : $f_0 = 58.75$ MHz, 87.5%AM, 84 dB μ V, standard TV signal (V / S = 10 : 4 Ramp) IF AGC : free

Measure deferential gain and deferential phase.

- Note 7: Signal-noise ratio
 (1) PIF input : $f_0 = 58.75$ MHz, $f_m = 15.75$ kHz, 30%AM, 84 dB μ V
 Measure IF AGC voltage and supply that voltage from external source.
 (2) Measure output video signal voltage. : V_1
 (3) PIF input : $f_0 = 58.75$ MHz, 84 dB μ V, CW
 Measure output video signal voltage. : V_2
 Signal-noise ratio is calculated by following equality.
 Signal-noise ratio = $20 \log (V_1 \times 6 / V_2)$ [dB]
- Note 8: Intermodulation
 (1) PIF input : $f_0 = 58.75$ MHz, 84 dB μ V, CW
 Supply DC voltage to IF AGC from external source to fix IF AGC voltage.
 (2) PIF input : following composite signals
 $f_0 = 58.75$ MHz, 84 dB μ V, CW
 $f_c = 55.17$ MHz, 74 dB μ V, CW
 $f_s = 54.25$ MHz, 74 dB μ V, CW
 Input
 Measure the difference of signal level at pin 24 920 kHz component and 3.58 MHz component (Chroma sub-carrier).
- Note 9: Suppression of picture career
 (1) PIF input : $f_0 = 58.75$ MHz, $f_m = 15.75$ kHz, 78%AM, 84 dB μ V
 Measure IF AGC voltage and supply that voltage from external source.
 (2) Measure output video signal voltage. : V_1
 (3) PIF input : $f_0 = 58.75$ MHz, 84 dB μ V, CW
 Measure signal level of 58.75 MHz component at pin 24. : V_2
 Signal-noise ratio is calculated by following equality.
 Suppression of picture career = $20 \times \log (V_1 / V_2)$ [dB]
- Note 10: Output voltage at no signal
 PIF input : no input IF AGC : GND
 Measure output video signal DC voltage.
- Note 11: Black noise inverter level / Black noise clamp level
 PIF input : $f_0 = 58.75$ MHz, $f_m = 15.75$ kHz, 78%AM, 84 dB μ V
 Supply 0 V to IF AGC from external source. Raise that voltage gradually, measure black noise inverter level.

<SIF circuit>

- Note 12: Output signal voltage
SIF input : $f_0 = 4.5$ MHz, $f_m = 400$ Hz, 25 kHz / devi, 84 dB μ V
Measure output audio signal voltage.
- Note 13: SIF input signal voltage sensitivity
SIF input : $f_0 = 4.5$ MHz, $f_m = 400$ Hz, 25 kHz / devi, 84 dB μ V
Measure output audio signal voltage (that voltage is 0 dB). Lower input SIF signal voltage gradually, measure input SIF signal voltage when output audio signal voltage is -3 dB.
- Note 14: Total harmonic distortion
SIF input : $f_0 = 4.5$ MHz, $f_m = 400$ Hz, 7.5 kHz / devi, 84 dB μ V
- Note 15: AM Rejection
SIF input :
(1) FM : $f_0 = 4.5$ MHz, $f_m = 400$ Hz, 25 kHz / devi, 84 dB μ V
(2) AM : $f_0 = 4.5$ MHz, $f_m = 400$ Hz, 30%AM, 84 dB μ V
Measure difference of output audio signal voltage between (1) and (2).
- Note 16: Signal-noise ratio
SIF input : $f_0 = 4.5$ MHz, $f_m = 400$ Hz, 25 kHz / devi, 84 dB μ V
Measure audio signal output voltage. : V_1 [mV $_{rms}$]
SIF input : $f_0 = 4.5$ MHz, $f_m = 400$ Hz, 25 kHz / devi, 84 dB μ V
Measure audio signal output voltage. : V_2 [mV $_{rms}$]
Signal-noise ratio is calculated by following equality.
Signal-noise ratio = $20 \log (V_1 / V_2)$ [dB]
- Note 17: -3 dB bandwidth
SIF input : $f_0 = 4.5$ MHz, $f_m = 400$ Hz, 25 kHz / devi, 84 dB μ V
Measure audio signal output voltage (that voltage is 0 dB). Then change input signal frequency, measure bandwidth that audio signal output voltage within -3 dB.
- Note 18: Dependence of output signal voltage on power supply voltage
SIF input : $f_0 = 4.5$ MHz, $f_m = 400$ Hz, 25 kHz / devi, 84 dB μ V
Measure the audio signal output voltage when power supply voltage are 3.5 V and 5.5 V. (4.5 \pm 1.0 V)
Compare those voltage and audio signal output voltage when power supply voltage is 4.5 V.
- Note 19: Audio amp. voltage gain
Audio input : $f = 1$ kHz, $V_{IN} = 100$ mV $_{rms}$, Pin 11 : VCC

- Note 20: Audio amp. total harmonic distortion
Audio input : $f = 1 \text{ kHz}$, $V_{IN} = 100 \text{ mV}_{rms}$, Pin 11 = VCC
- Note 21: Audio amp. maximum attenuation
Audio input : $f = 1 \text{ kHz}$, $V_{IN} = 100 \text{ mV}_{rms}$
Audio output (Pin 11: VCC) = V_{max}
Audio output (Pin 11: GND) = V_{min}
 $ATT_{max} = 20 \log (V_{max} / V_{min})$
- Note 22: Audio amp. S / N
(1) Audio input : $f = 1 \text{ kHz}$, $V_{IN} = 100 \text{ mV}_{rms}$, Pin 11 = VCC
Measure audio output : V_1
(2) Audio input : No signal
Measure audio output : V_2
 $S / N = 20 \log (V_1 / V_2) \text{ [dB]}$
- Note 23: Audio amp. output power
Audio input : $f = 1 \text{ kHz}$, Pin 11 = VCC, Load = 8Ω
Raise input signal voltage gradually, measure output signal voltage when THD is 5%.
 $P_o = V^2 / 8 \text{ [W]}$

TEST CIRCUIT 1 (DC CHARACTERISTIC)

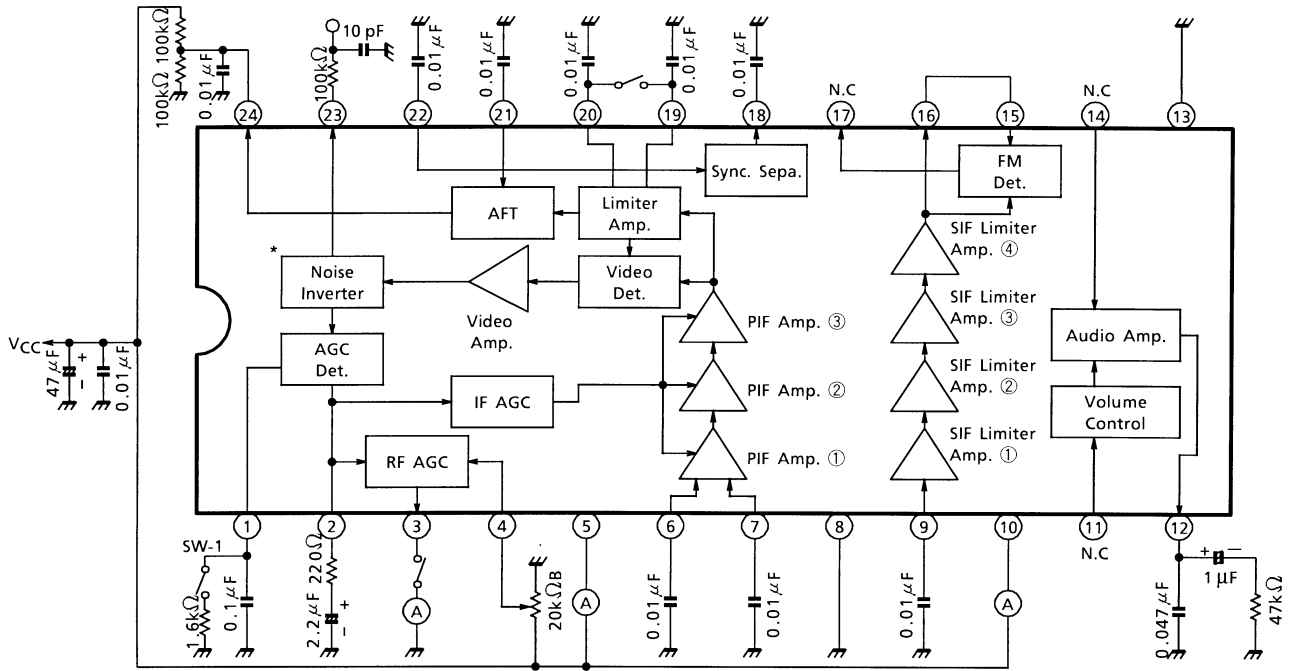

TEST CIRCUIT 2 (AC CHARACTERISTIC)

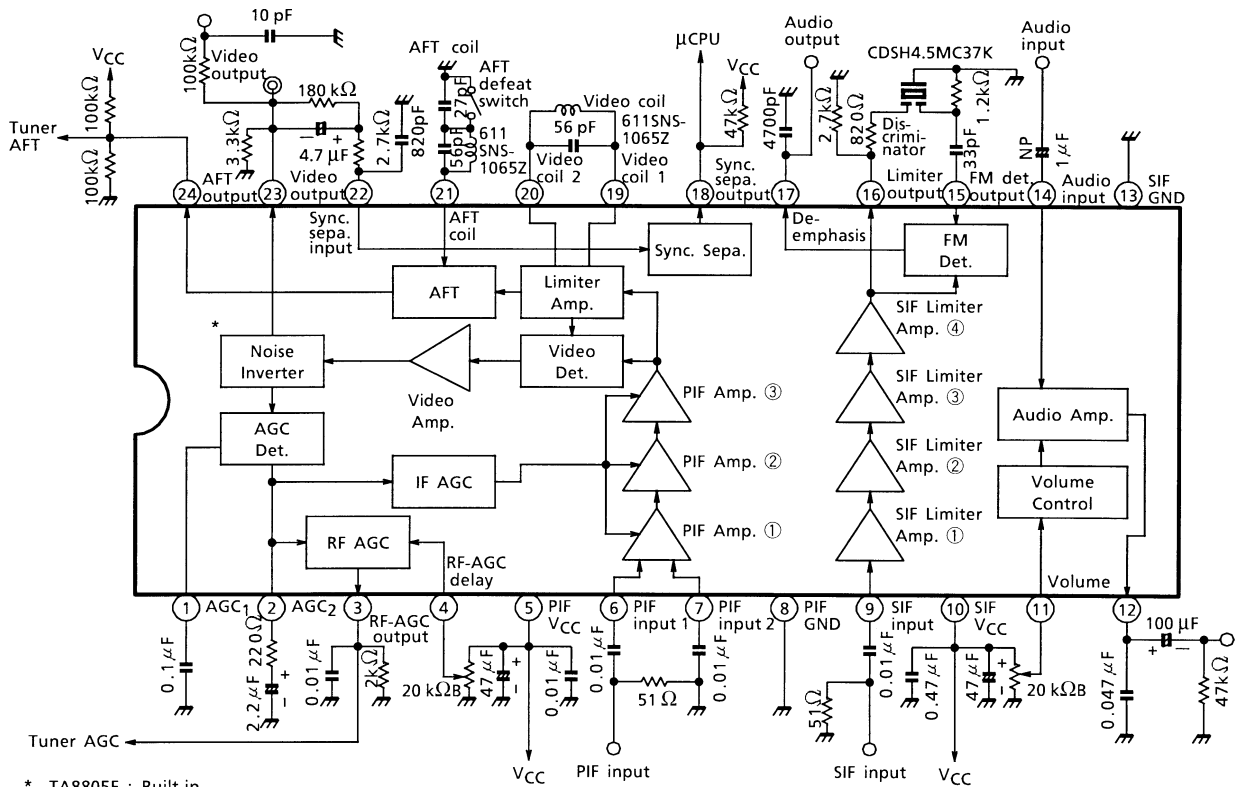

* TA8805F : Built-in
TA1207F : Non built-in

TEST CIRCUIT 3 (DG, DP)

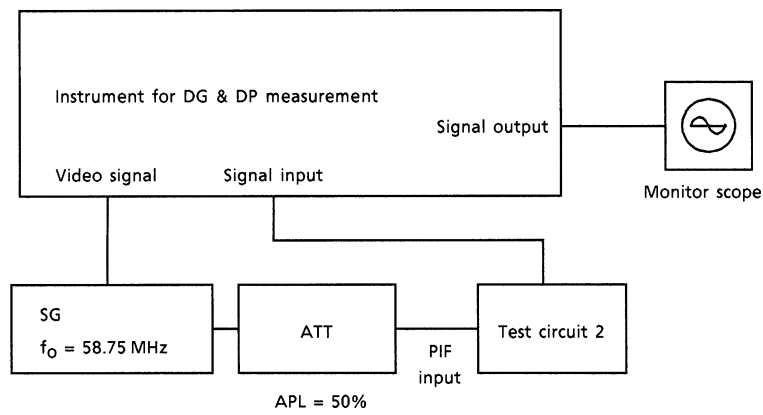

TEST CIRCUIT 4 (INTERMODULATION)

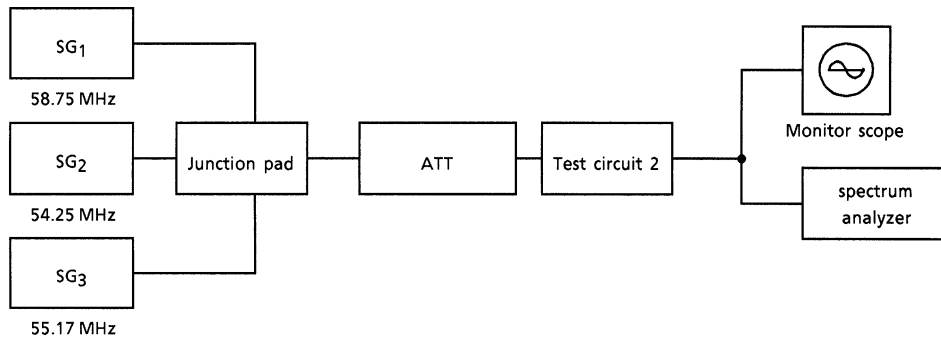

TEST CIRCUIT 5 (AMR)

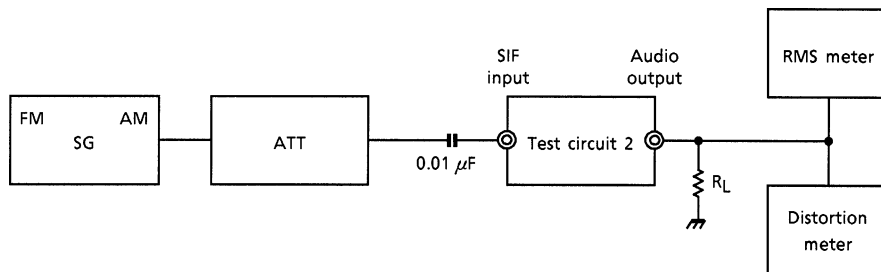

COIL ADJUSTMENT

- Video coil

Measure video signal output DC voltage.

IF AGC : Fix voltage for external voltage source/

PIF input : 58.75MHz, 84dB μ V, CW

Adjust video coil so that video signal output DC voltage is lowest.

- AFT coil

Measure video signal output AFT voltage.

PIF input : 54~62MHz(sweep signal), 84dB μ V

Adjust AFT coil so that AFT output signal is following figure.

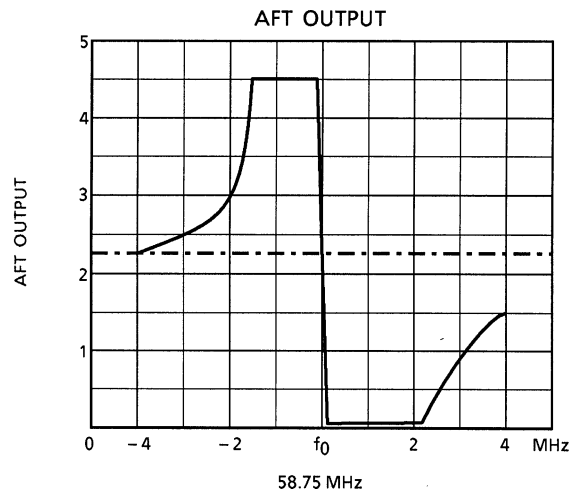

- SIF coil

SIF input : $f_0 = 4.5\text{MHz}$, 84dB μ V, CW

Adjust SIF coil so that pin 17 voltage is $1/2 V_{CC}$.

COILE SPECIFICATION

COIL NAME	PART NUMBER	CONNECTION	SPECIFICATION
Video AFT	611SNS-1065Z (TOKO)		Center frequency : 58.75 MHz Internal capacitor : — External capacitor : — Frequency adjustment range : ±4% Qu : 72 ± 20% Size : 5 mm × 5 mm
SIF	F292MCAS-32971B (TOKO)		Center frequency : 4.5 MHz Internal capacitor : 100 pF External capacitor : — Frequency adjustment range : ±3% Qu : 20 ± 20% Size : 7 mm × 7 mm

APPLICATION CIRCUIT

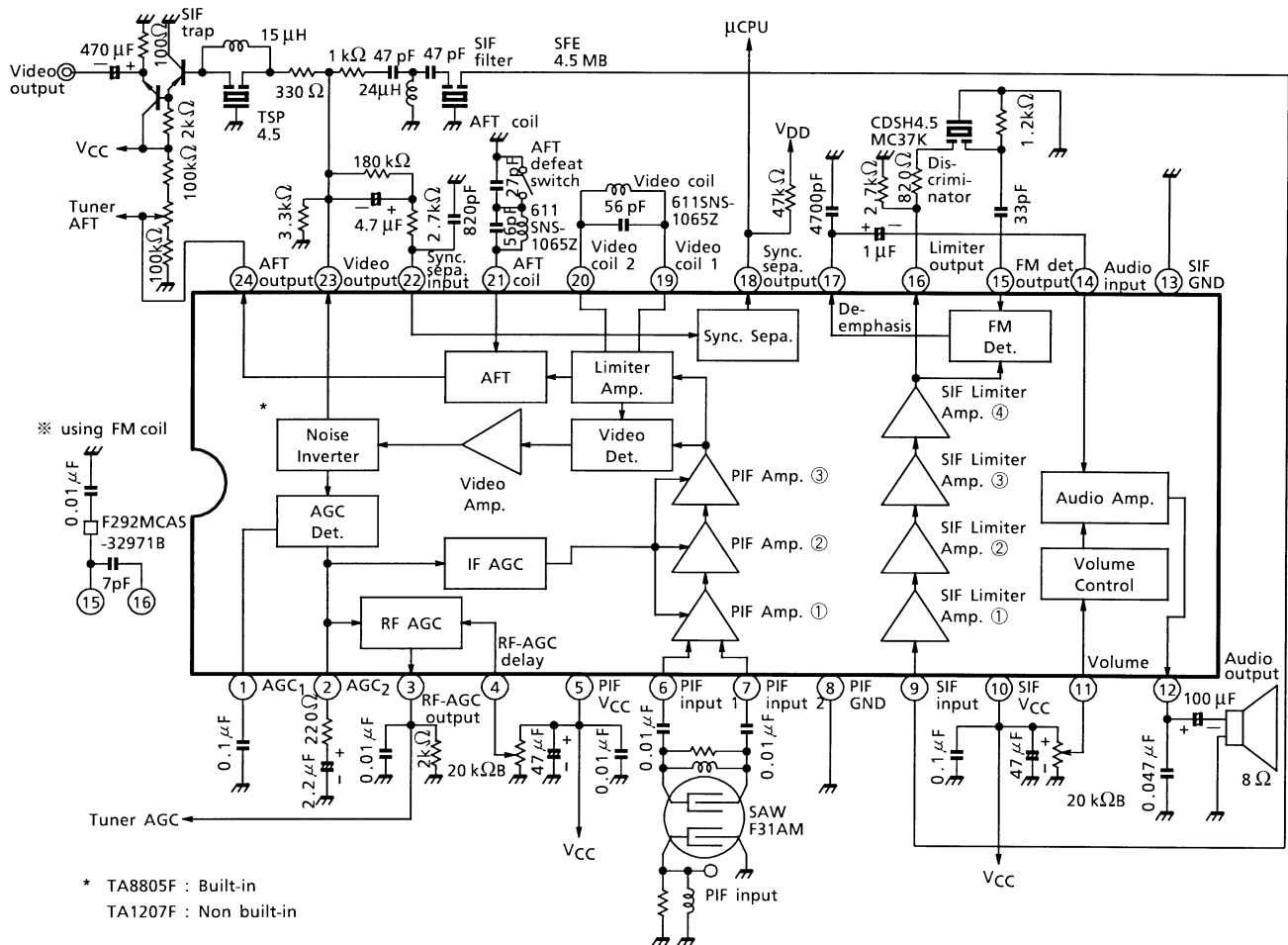

PACKAGE DIMENSIONS

SSOP24-P-300-1.00

Unit : mm

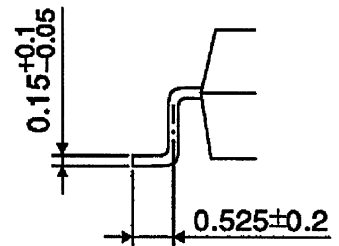
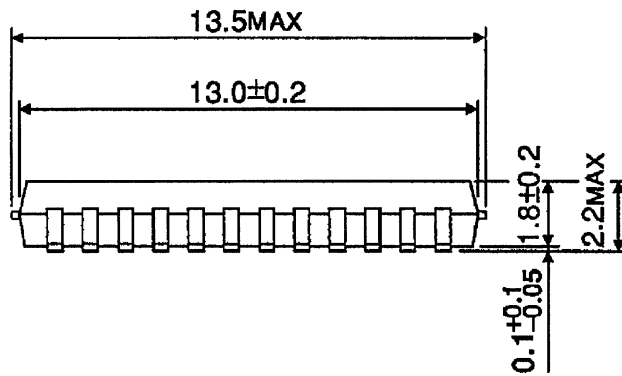
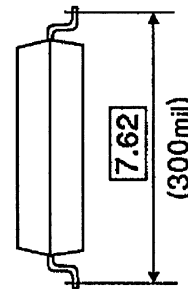

Weight: 0.32 g (Typ.)