

6N137

DIGITAL LOGIC ISOLATION
 TELE-COMMUNICATION
 ANALOG DATA EQUIPMENT CONTROL

The TOSHIBA 6N137 consist of a high emitting diode and a one chip photo IC. This unit is 8-lead DIP package.

- LSTTL/TTL Compatible : 5V Supply
- Ultra High Speed : 10MBd
- Guaranteed Performance Over Temperature : 0°C to 70°C
- High Isolation Voltage : 2500Vrms Min.
- UL Recognized : UL1577, File No. E67349

TRUTH TABLE

INPUT	ENABLE	OUTPUT
H	H	L
L	H	H
H	L	H
L	L	H

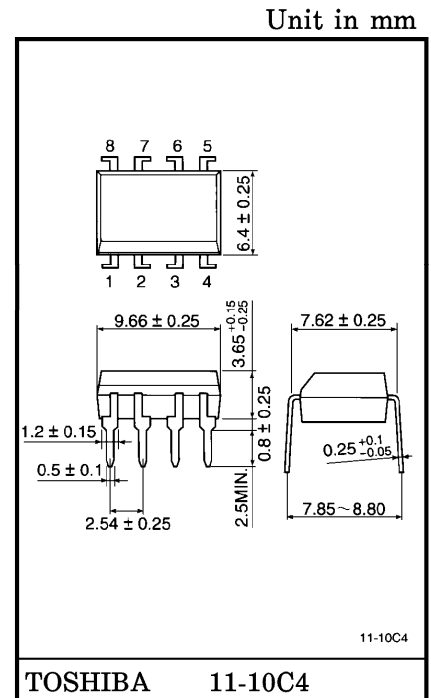
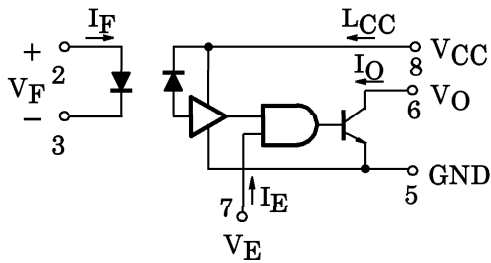

Weight : 0.54g

PIN CONFIGURATIONS (Top view)

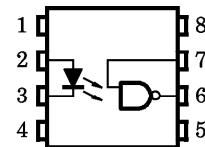

- 1 : N.C.
- 2 : ANODE
- 3 : CATHODE
- 4 : N.C.
- 5 : GND
- 6 : OUTPUT (OPEN COLLECTOR)
- 7 : ENABLE
- 8 : VCC

MAXIMUM RATINGS

CHARACTERISTIC		SYMBOL	RATING	UNIT
LED	Forward Current	I_F	20	mA
	Pulse Forward Current (Note 1)	I_{FP}	40	mA
	Reverse Voltage	V_R	5	V
DETECTOR	Output Current	I_O	50	mA
	Output Voltage	V_O	7	V
	Supply Voltage (1 minute Maximum)	V_{CC}	7	V
	Enable Input Voltage (Not to exceed V_{CC} by More than 500mV)	V_{EH}	5.5	V
	Output Collector Power Dissipation	P_O	85	mW
	Operating Temperature Range	T_{opr}	0~70	°C
	Storage Temperature Range	T_{stg}	-55~125	°C
Lead Solder Temperature (10s) (Note 2)	T_{sol}	260	°C	

(Note 1) 50% duty cycle, 1ms Pulse width.

(Note 2) Soldering portion of lead : up to 2mm from the body of the device.

RECOMMENDED OPERATING CONDITIONS

CHARACTERISTIC	SYMBOL	MIN.	MAX.	UNIT
Input Current, Low Level Each Channel	I_{FL}	0	250	μA
Input Current, High Level Each Channel	I_{FH}	7	20	mA
High Level Enable Voltage	V_{EH}	2.0	V_{CC}	V
Low Level Enable Voltage (Output High)	V_{EL}	0	0.8	V
Supply Voltage, Output	V_{CC}	4.5	5.5	V
Fan Out (TTL LOAD)	N	—	8	—
Operating Temperature	T_a	0	70	°C

PRECAUTION

Please be careful of the followings.

A ceramic capacitor (0.1 μF) should be connected from pin 8 to pin 5 to stabilize the operation of the high gain linear amplifier. Failure to provide the bypassing may impair the switching property. The total lead length between capacitor and coupler should not exceed 1cm.

ELECTRICAL CHARACTERISTICS
OVER RECOMMENDED TEMPERATURE ($T_a = 0 \sim 70^\circ\text{C}$ unless otherwise noted)

CHARACTERISTIC	SYMBOL	TEST CONDITION	MIN.	(**)TYP.	MAX.	UNIT
High Level Output Current	I_{OH}	$V_{CC} = 5.5\text{V}$, $V_O = 5.5\text{V}$ $I_F = 250\mu\text{A}$, $V_E = 2.0\text{V}$	—	1	250	μA
Low Level Output Voltage	V_{OL}	$V_{CC} = 5.5\text{V}$, $I_F = 5\text{mA}$ $V_{EH} = 2.0\text{V}$ I_{OL} (Sinking) = 13mA	—	0.4	0.6	V
High Level Enable Current	I_{EH}	$V_{CC} = 5.5\text{V}$, $V_E = 2.0\text{V}$	—	-1.0	—	mA
Low Level Enable Current	I_{EL}	$V_{CC} = 5.5\text{V}$, $V_E = 0.5\text{V}$	—	-1.6	-2.0	mA
High Level Supply Current	I_{CCH}	$V_{CC} = 5.5\text{V}$, $I_F = 0$, $V_E = 0.5\text{V}$	—	7	15	mA
Low Level Supply Current	I_{CCL}	$V_{CC} = 5.5\text{V}$, $I_F = 10\text{mA}$ $V_E = 0.5\text{V}$	—	12	18	mA
Resistance (Input-Output) (Note 3)	R_{I-O}	$V_{I-O} = 500\text{V}$, $T_a = 25^\circ\text{C}$ R.H. $\leq 60\%$	—	10^{12}	—	Ω
Capacitance (Input-Output) (Note 3)	C_{I-O}	$f = 1\text{MHz}$, $T_a = 25^\circ\text{C}$	—	0.6	—	pF
Input Forward Voltage	V_F	$I_F = 10\text{mA}$, $T_a = 25^\circ\text{C}$	—	1.65	1.75	V
Input Reverse Breakdown Voltage	BV_R	$I_R = 10\mu\text{A}$, $T_a = 25^\circ\text{C}$	5	—	—	V
Input Capacitance	C_{IN}	$V_F = 0$, $f = 1\text{MHz}$	—	45	—	pF
Current Transfer Ratio	CTR	$I_F = 5.0\text{mA}$, $R_L = 100\Omega$	—	1000	—	%

(**) All typical values are at $V_{CC} = 5\text{V}$, $T_a = 25^\circ\text{C}$

(Note 3) Pins 1, 2, 3 and 4 shorted together and Pins 5, 6, 7 and 8 shorted together.

SWITCHING CHARACTERISTICS (Ta = 25°C, VCC = 5V)

CHARACTERISTIC	SYMBOL	TEST CIRCUIT	TEST CONDITION	MIN.	TYP.	MAX.	UNIT
Propagation Delay Time to High Output Level	t_{pLH}	1	$R_L = 350\Omega$, $C_L = 15pF$ $I_F = 7.5mA$	—	60	75	ns
Propagation Delay Time to Low Output Level	t_{pHL}	1	$R_L = 350\Omega$, $C_L = 15pF$ $I_F = 7.5mA$	—	60	75	ns
Output Rise-Fall Time (10-90%)	t_r , t_f	—	$R_L = 350\Omega$, $C_L = 15pF$ $I_F = 7.5mA$	—	30	—	ns
Propagation Delay Time of Enable from V_{EH} to V_{EL}	t_{ELH}	2	$R_L = 350\Omega$, $C_L = 15pF$ $I_F = 7.5mA$ $V_{EH} = 3.0V$ $V_{EL} = 0.5V$	—	25	—	ns
Propagation Delay Time of Enable from V_{EL} to V_{EH}	t_{EHL}	2	$R_L = 350\Omega$, $C_L = 15pF$ $I_F = 7.5mA$ $V_{EH} = 3.0V$ $V_{EL} = 0.5V$	—	25	—	ns
Common Mode Transient Immunity at Logic High Output Level	CM_H	3	$V_{CM} = 10V$ $R_L = 350\Omega$ $V_O (min.) = 2V$ $I_F = 0mA$	—	200	—	V / μs
Common Mode Transient Immunity at Logic Low Output Level	CM_L	3	$V_{CM} = 10V$ $R_L = 350\Omega$ $V_O (max.) = 0.8V$ $I_F = 5mA$	—	-500	—	V / μs

TEST CIRCUIT 1.

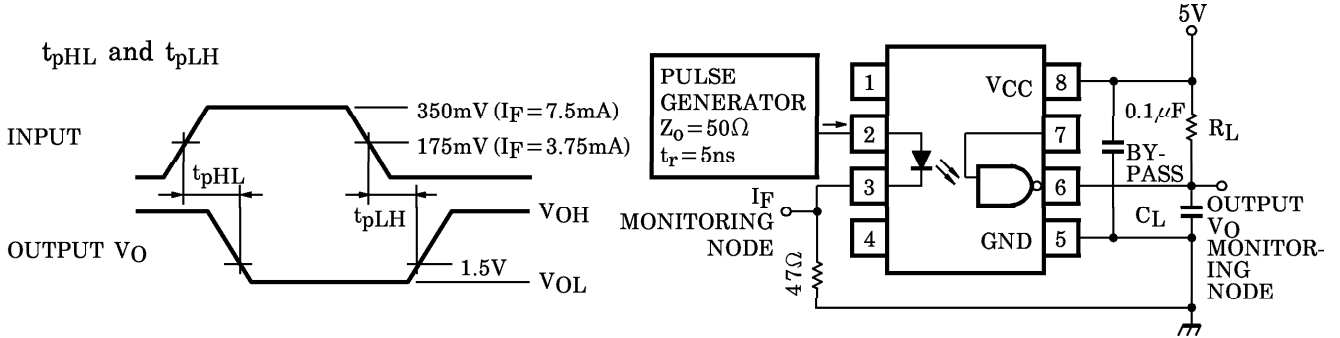

- C_L is approximately 15pF which includes probe and stray wiring capacitance.

TEST CIRCUIT 2.

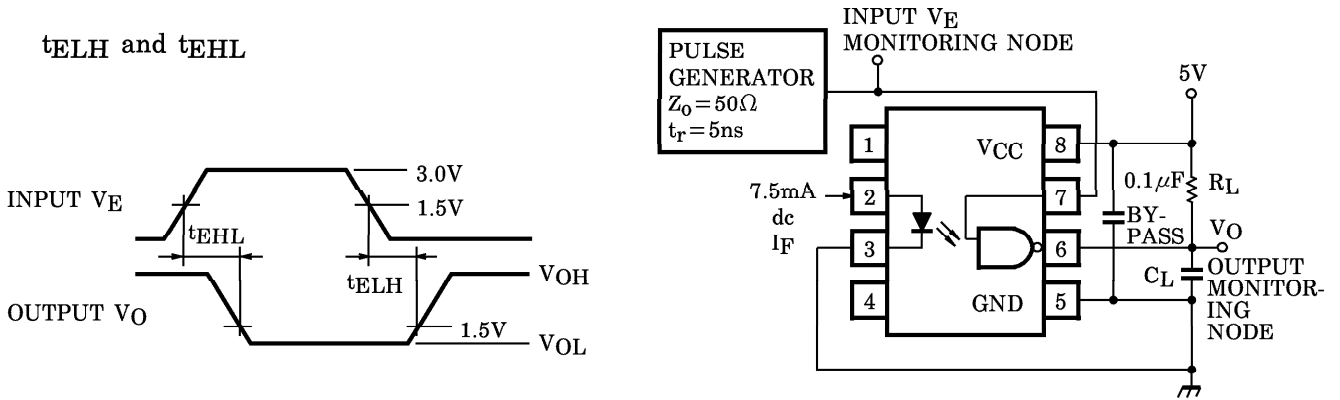

- C_L is approximately 15pF which includes prove and stray wiring capacitance.

TEST CIRCUIT 3.

Transient Immunity and Typical Waveforms

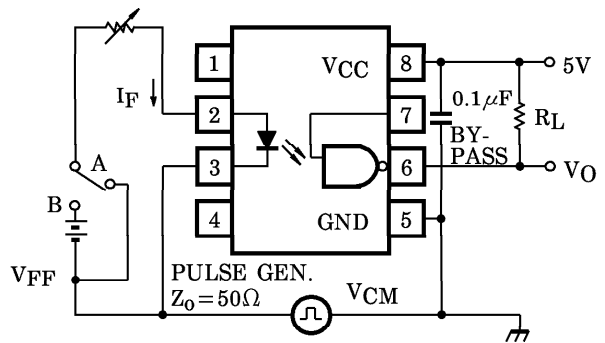
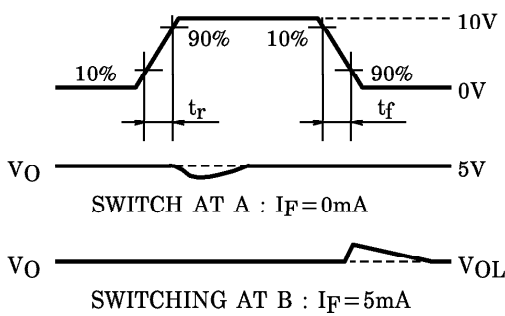

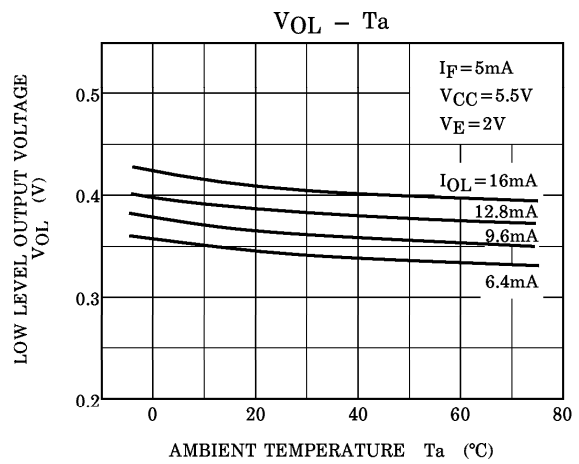
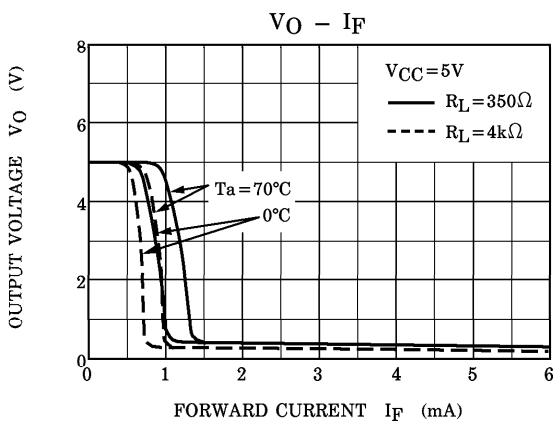
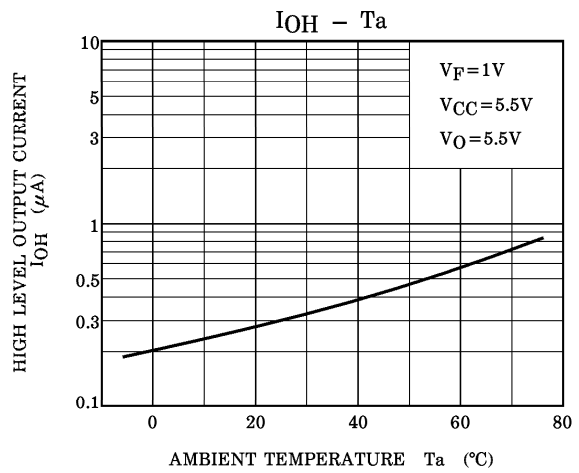
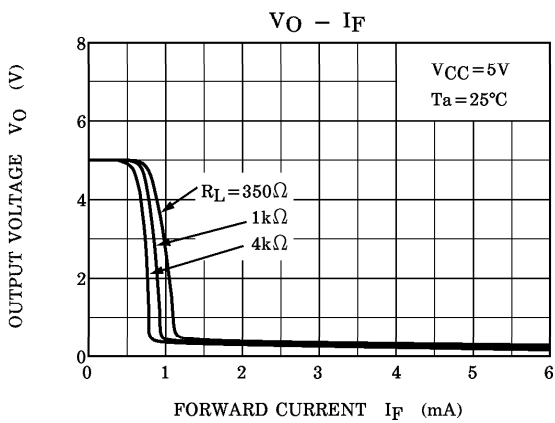
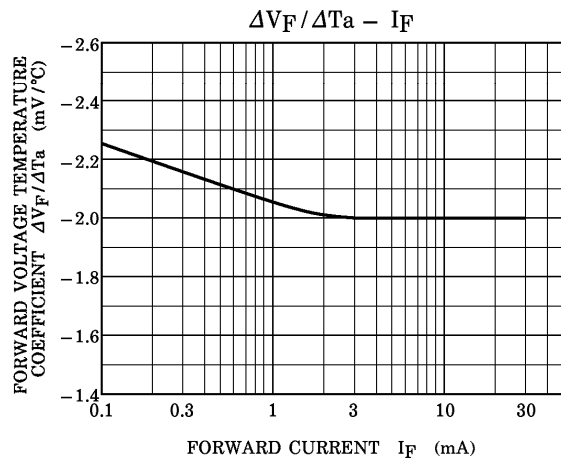
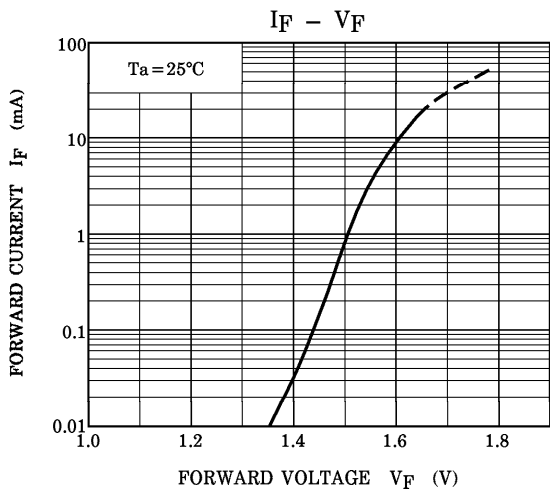

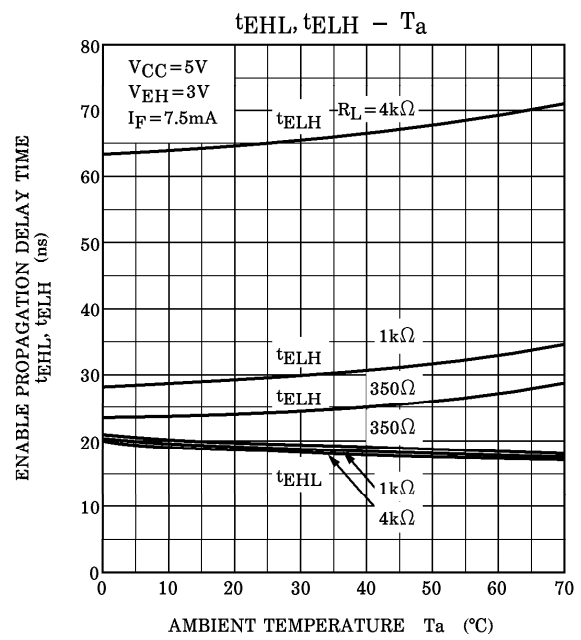
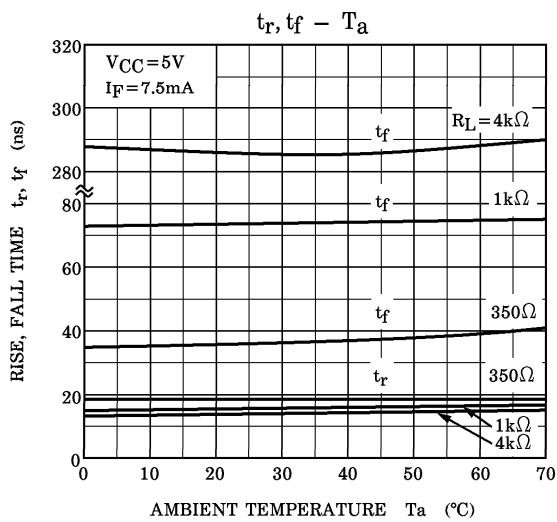
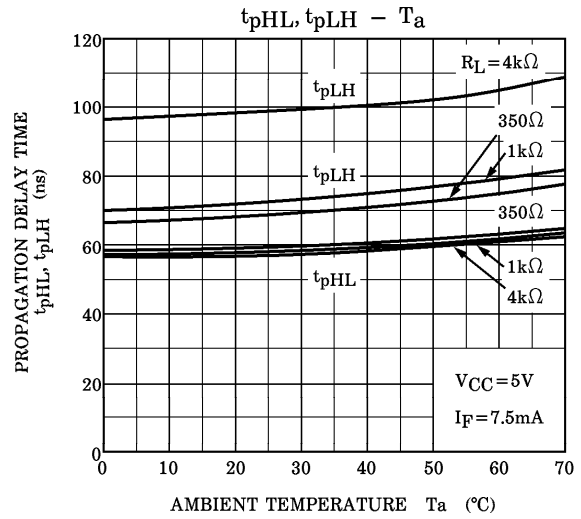
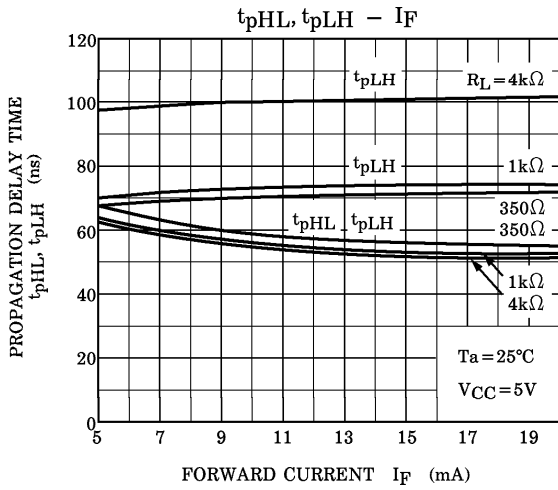

RESTRICTIONS ON PRODUCT USE

000707EBC

- TOSHIBA is continually working to improve the quality and reliability of its products. Nevertheless, semiconductor devices in general can malfunction or fail due to their inherent electrical sensitivity and vulnerability to physical stress. It is the responsibility of the buyer, when utilizing TOSHIBA products, to comply with the standards of safety in making a safe design for the entire system, and to avoid situations in which a malfunction or failure of such TOSHIBA products could cause loss of human life, bodily injury or damage to property. In developing your designs, please ensure that TOSHIBA products are used within specified operating ranges as set forth in the most recent TOSHIBA products specifications. Also, please keep in mind the precautions and conditions set forth in the "Handling Guide for Semiconductor Devices," or "TOSHIBA Semiconductor Reliability Handbook" etc..
- The TOSHIBA products listed in this document are intended for usage in general electronics applications (computer, personal equipment, office equipment, measuring equipment, industrial robotics, domestic appliances, etc.). These TOSHIBA products are neither intended nor warranted for usage in equipment that requires extraordinarily high quality and/or reliability or a malfunction or failure of which may cause loss of human life or bodily injury ("Unintended Usage"). Unintended Usage include atomic energy control instruments, airplane or spaceship instruments, transportation instruments, traffic signal instruments, combustion control instruments, medical instruments, all types of safety devices, etc.. Unintended Usage of TOSHIBA products listed in this document shall be made at the customer's own risk.
- Gallium arsenide (GaAs) is a substance used in the products described in this document. GaAs dust and fumes are toxic. Do not break, cut or pulverize the product, or use chemicals to dissolve them. When disposing of the products, follow the appropriate regulations. Do not dispose of the products with other industrial waste or with domestic garbage.
- The products described in this document are subject to the foreign exchange and foreign trade laws.
- The information contained herein is presented only as a guide for the applications of our products. No responsibility is assumed by TOSHIBA CORPORATION for any infringements of intellectual property or other rights of the third parties which may result from its use. No license is granted by implication or otherwise under any intellectual property or other rights of TOSHIBA CORPORATION or others.
- The information contained herein is subject to change without notice.