

18-31GHz Low Noise Amplifier

GaAs Monolithic Microwave IC

Description

The circuit is a three-stage self biased wide band monolithic low noise amplifier.

The circuit is manufactured with a standard HEMT process : 0.25 μ m gate length, via holes through the substrate, air bridges and electron beam gate lithography.

It is supplied in chip form.

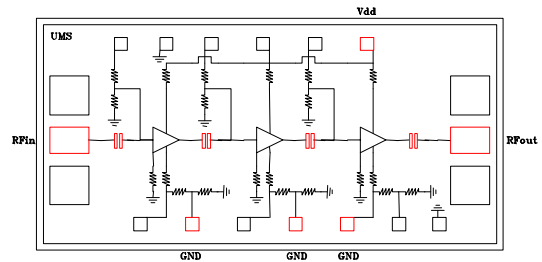

Main Features

- Broad band performance 18-31GHz
- 2.5dB noise figure
- 22dB gain, ± 1 dB gain flatness
- Low DC power consumption, 55mA
- 20dBm 3rd order intercept point
- Chip size : 2,170 x 1,270x 0.1mm

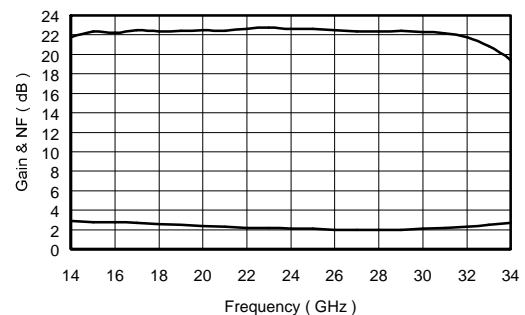

On wafer typical measurements.

Main Characteristics

Tamb = +25°C

Symbol	Parameter	Min	Typ	Max	Unit
NF	Noise figure,18-31GHz		2.5	3.5	dB
G	Gain	18	22		dB
Δ G	Gain flatness		± 1	± 1.5	dB

ESD Protections : Electrostatic discharge sensitive device observe handling precautions !

Electrical Characteristics

Tamb = +25°C, Vd = +4,5V Pads:B=D=E=Gnd

Symbol	Parameter	Min	Typ	Max	Unit
Fop	Operating frequency range	18		31	Ghz
G	Gain (1)	18	22		dB
ΔG	Gain flatness (1)		± 1	± 1.5	dB
NF	Noise figure (1)		2.5	3.5	dB
VSWRin	Input VSWR (1)		2.0:1	2.5:1	
VSWRout	Ouput VSWR (1)		2:0:1	2.5:1	
IP3	3rd order intercept point		20		dBm
P1dB	Output power at 1dB gain compression		10		dBm
Id	Drain bias current (2)		55	75	mA

(1) These values are representative on-wafer measurements that are made without bonding wires at the RF ports.

(2) This current is the typical value from the low noise low consumption biasing (B & D & E grounded).

Absolute Maximum Ratings (3)

Tamb = +25°C

Symbol	Parameter	Values	Unit
Vd	Drain bias voltage (5)	5.0	V
Pin	Maximum peak input power overdrive (4)	+15	dBm
Top	Operating temperature range	-40 to +85	°C
Tstg	Storage temperature range	-55 to +125	°C

(3) Operation of this device above anyone of these paramaters may cause permanent damage.

(4) Duration < 1s.

(5) See chip biasing options pp7

Typical Result**Chip Typical Response (On wafer Sij) :**

Tamb = +25°C VD=4.5V ID =+55 mA

F(GHz)	S11		S12		S21		S22	
	mod	pha	mod	Pha	mod	pha	mod	pha
	dB	deg	dB	Deg	dB	deg	dB	deg
2	-0.01	-34.9	-83.58	-127.8	-63.71	-13.4	-1.00	-119.2
4	-0.01	-71.6	-76.83	108.8	-58.71	67.0	-1.47	175.5
6	-0.15	-112.7	-66.00	60.8	-23.56	-164.4	-2.32	127.4
8	-0.74	-164.6	-71.92	-16.4	1.54	82.3	-3.60	81.3
10	-3.30	128.2	-70.19	-49.4	12.91	-27.1	-5.05	47.4
11	-5.18	90.4	-59.14	-73.7	16.99	-80.0	-5.37	16.5
12	-6.94	50.5	-54.33	-122.3	19.60	-134.0	-7.20	-11.0
13	-7.98	11.7	-51.51	-169.1	21.14	175.3	-9.15	-34.1
14	-8.31	-23.4	-50.07	149.9	21.66	129.6	-11.20	-56.3
15	-8.58	-54.0	-49.42	116.2	22.18	87.5	-13.60	-77.5
16	-9.01	-77.8	-49.02	87.9	22.07	51.3	-16.65	-96.6
17	-9.66	-97.0	-49.24	56.9	22.35	17.5	-21.01	-115.6
18	-10.27	-112.2	-49.74	38.9	22.25	-13.3	-28.25	-138.6
19	-11.44	-125.0	-48.80	9.0	22.30	-43.3	-29.93	70.6
20	-12.60	-132.7	-50.27	-20.2	22.38	-72.0	-20.66	26.9
21	-13.74	-137.8	-50.08	-36.8	22.38	-99.8	-16.29	8.9
22	-14.44	-140.0	-50.55	-62.5	22.60	-127.6	-13.67	-8.6
23	-15.21	-142.8	-51.54	-81.8	22.72	-155.4	-12.01	-23.6
24	-16.15	-144.4	-51.68	-101.2	22.60	176.7	-10.83	-36.2
25	-16.91	-142.9	-53.88	-123.9	22.65	148.6	-10.08	-48.8
26	-17.29	-139.8	-55.05	-131.7	22.52	121.6	-9.73	-59.3
27	-16.84	-139.8	-56.50	-130.9	22.33	95.0	-9.58	-69.9
28	-16.95	-147.5	-54.45	-134.4	22.31	68.4	-9.80	-78.4
29	-20.07	-167.5	-52.53	-163.2	22.38	40.0	-10.82	-83.0
30	-30.52	-155.1	-54.62	-174.1	22.26	11.1	-11.30	-83.9
31	-27.00	-17.8	-53.75	179.4	22.16	-19.5	-11.94	-81.7
32	-14.97	-22.9	-53.19	178.6	21.80	-52.8	-11.76	-73.8
33	-9.33	-43.0	-51.06	149.6	21.01	-87.4	-10.65	-68.9
34	-5.88	-63.5	-52.88	130.3	19.68	-122.9	-9.14	-68.4
35	-3.76	-82.7	-49.61	134.9	17.65	-157.6	-7.96	-71.3
36	-2.43	-100.5	-47.83	116.4	15.15	170.2	-6.97	-75.0
37	-1.79	-116.2	-52.98	85.7	12.27	141.0	-6.11	-79.3
38	-1.35	-129.6	-46.64	67.5	9.27	114.2	-5.37	-83.2
39	-1.14	-140.6	-59.58	31.3	6.10	90.1	-4.70	-87.6
40	-0.83	-151.3	-54.65	61.1	2.95	68.0	-4.13	-92.4

Typical Results

Chip Typical Response (On wafer Si) :

Tamb = +25°C

Vd = 4.5V ; B , D & E=GND; Id = 55mA

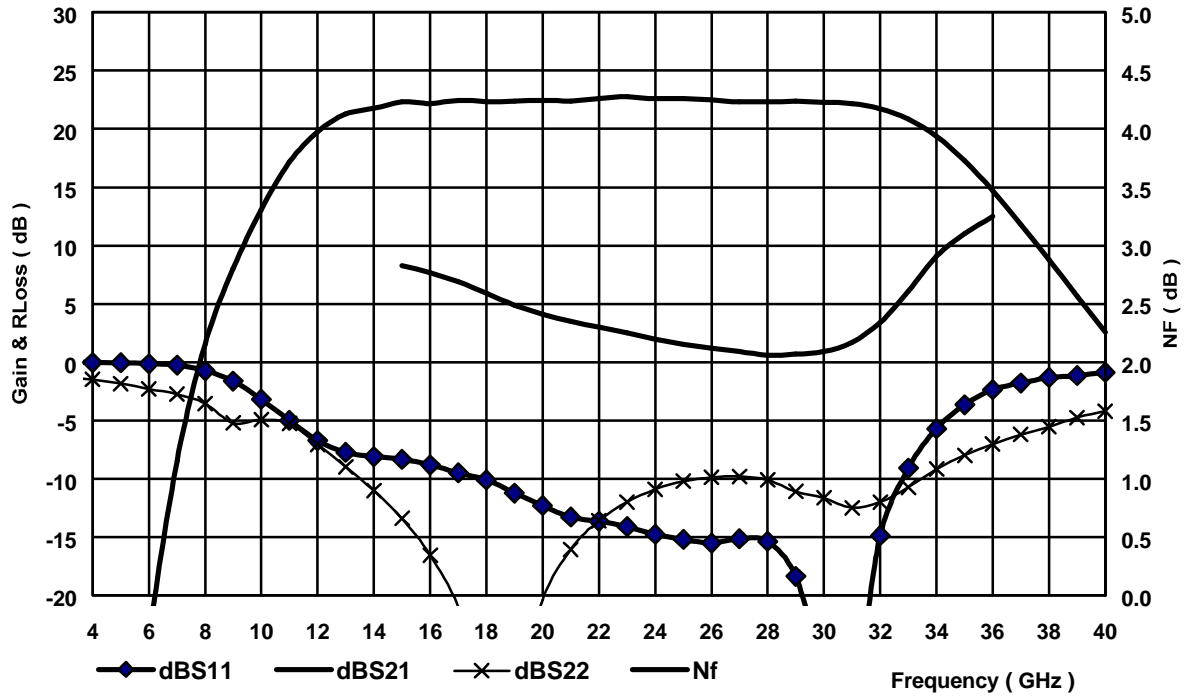

Typical Gain and Matching measurements on wafer.

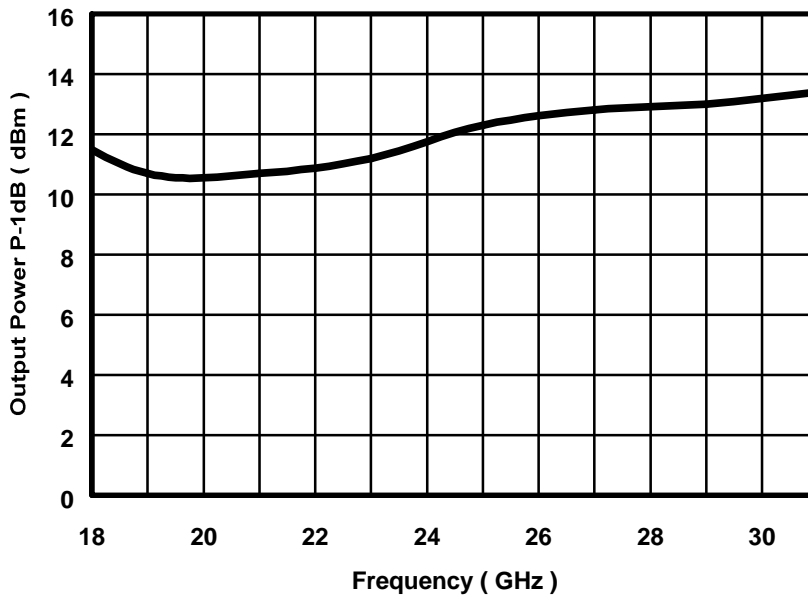

Typical Poutput Power -1dB measurements on wafer.

Typical Test-Jig Results

Circuit Typical Response (Test-Jig) :

Tamb = +25°C Vd = 4.5V ; B ,D & E =Pads grounded ; Id = 55mA
 (G1, G2, A, C & F non connected)

These values are representative of the package assembly with input and output bonding wires of typically 0.15nH.

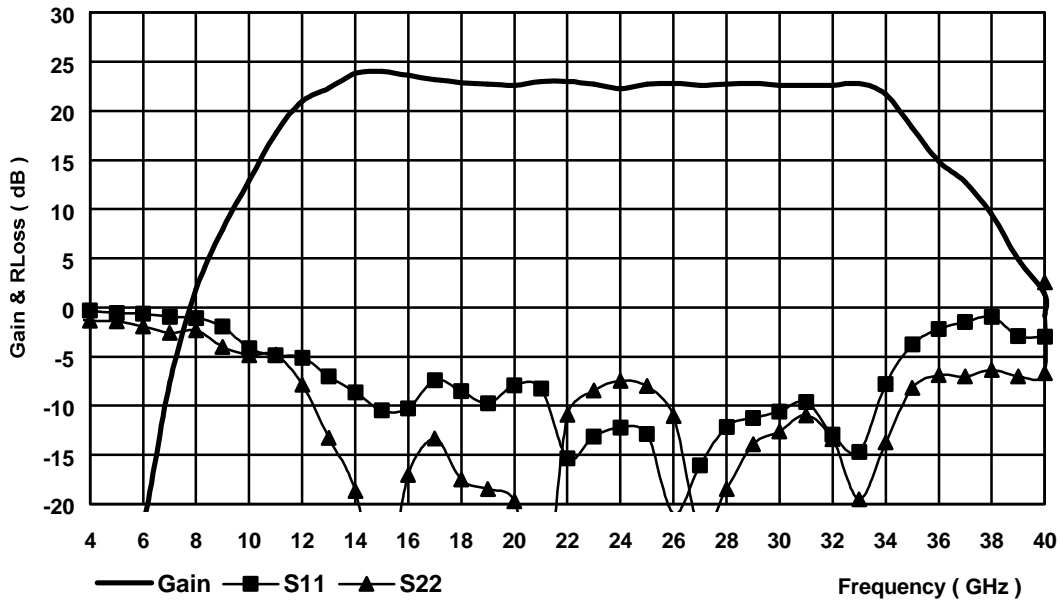

Typical Linear measurements in test-jig.

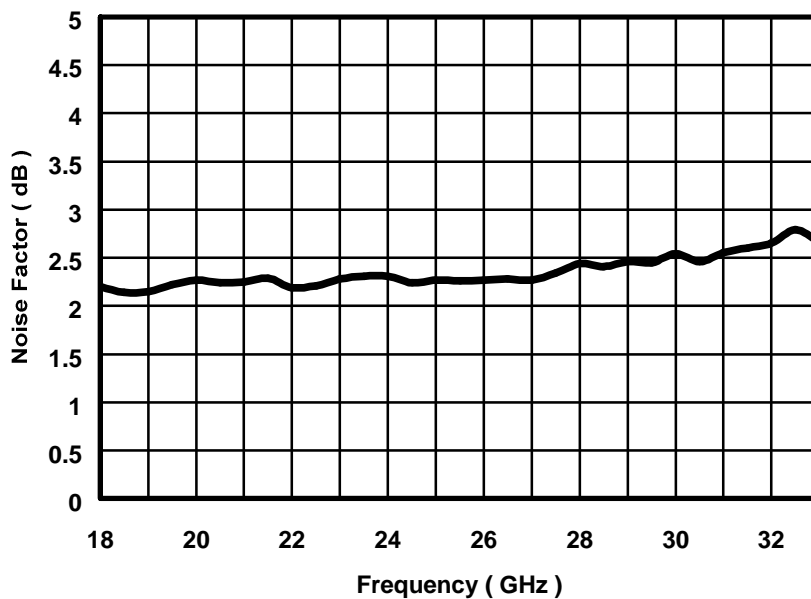

Typical NOISE Figure measurements in test-jig.

Chip schematic and Pad Identification

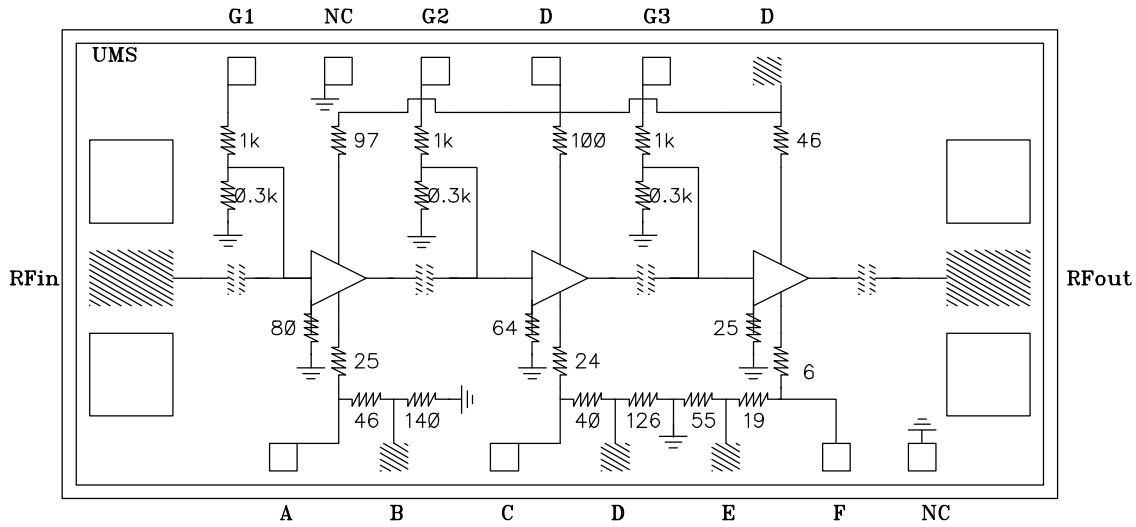

Pad Size :100/80um, chip thickness 100um
 Dimensions : 2170 x 1270um ± 35µm

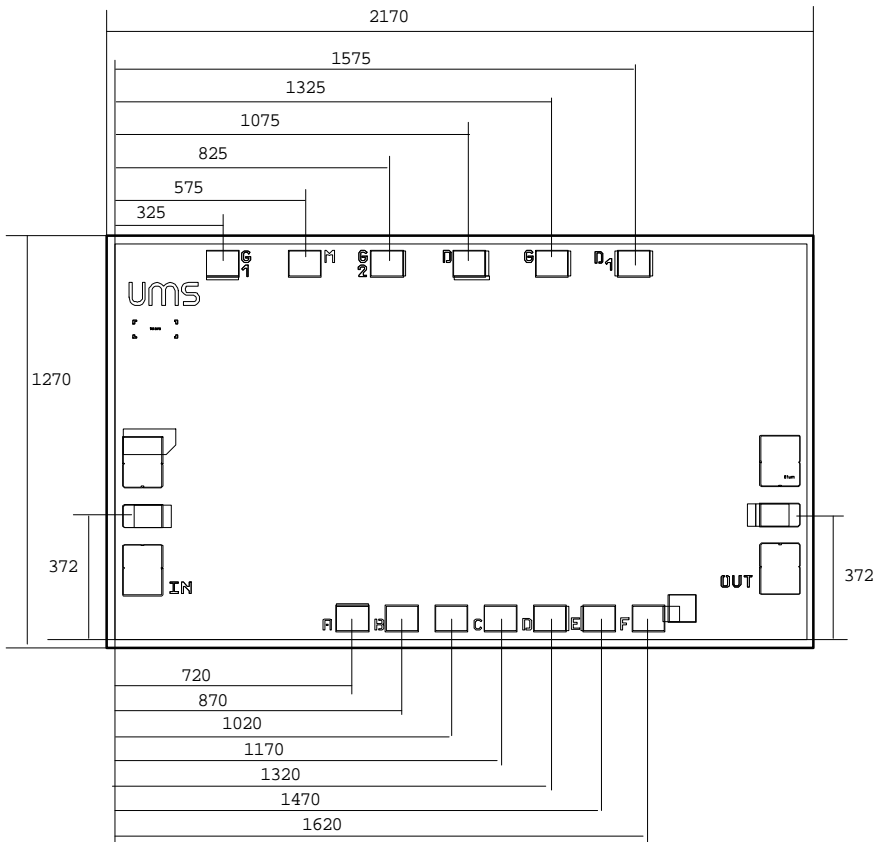

Typical Chip Assembly

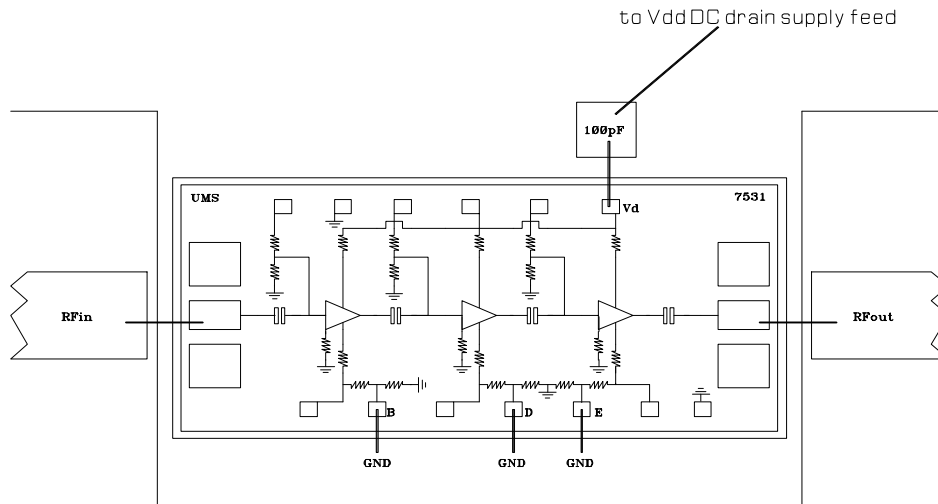

Chip Biasing options

This chip is self-biased, and flexibility is provided by the access to number of pads. the internal DC electrical schematic is given in order to use these pads in a safe way.

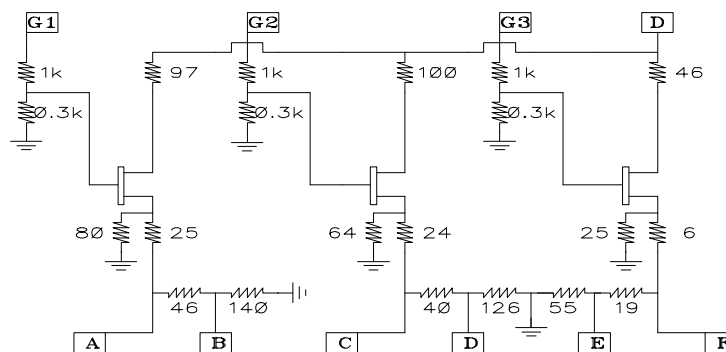

The two requirements are :

N°1 : Not exceed $V_{ds} = 3.5\text{Volt}$ (internal Drain to Source voltage).

N°2 : Not biased in such a way that V_{gs} becomes positive.
(internal Gate to Source voltage)

We propose two standard biasing :

Low Noise and low consumption :

$V_d = 4.5\text{V}$ and B, D, E grounded.

All the other pads non connected (NC).

$I_{dd} = 55\text{mA}$ & $P_{out-1dB} = 10\text{dBm}$ Typical.

(Equivalent to A,B,C,D,E F: non connected and $V_d=4.5\text{V}$; $G1=G2=G3=+1\text{V}$).

Low Noise and higher output power

$V_d = 4.5\text{V}$ and B, C, F grounded.

All the other pads non connected (NC).

$I_{dd} = 75\text{mA}$ & $P_{out-1dB} = 12\text{dBm}$ Typical..

Ordering Information

Chip form : CHA2069-99F/00

Information furnished is believed to be accurate and reliable. However **United Monolithic Semiconductors S.A.S.** assumes no responsibility for the consequences of use of such information nor for any infringement of patents or other rights of third parties which may result from its use. No license is granted by implication or otherwise under any patent or patent rights of **United Monolithic Semiconductors S.A.S.** Specifications mentioned in this publication are subject to change without notice. This publication supersedes and replaces all information previously supplied. **United Monolithic Semiconductors S.A.S.** products are not authorised for use as critical components in life support devices or systems without express written approval from **United Monolithic Semiconductors S.A.S.**