

1A LOW DROPOUT POSITIVE
FIXED OUTPUT REGULATOR

PRELIMINARY DATASHEET

FEATURES

- **Guaranteed < 1.3V Dropout at Full Load Current**
- **Fast Transient Response**
- **1% Output Voltage Initial Accuracy**
- **Built-in Thermal Shutdown**
- **Available in SOT-223, D-PAK , Power Flex and 8 pin SOIC Surface Mount Packages**

APPLICATIONS

- VGA & Sound Card Applications
- Standard 3.3V Chip-Set and Logic Applications

DESCRIPTION

The US1010-33 is a low dropout three terminal fixed output regulator with minimum of 1A output current capability. This product is specifically designed to provide well regulated supply for low voltage IC applications such as VGA , sound & DVD cards. The US 1010 is **guaranteed to have <1.3V drop out at full load current** making it ideal to provide well regulated with 4.75V to 7V input supply. The US1010 is specifically designed to be stable with low cost Aluminium capacitors while still maintains stability with low ESR tantalum caps as well.

TYPICAL APPLICATION

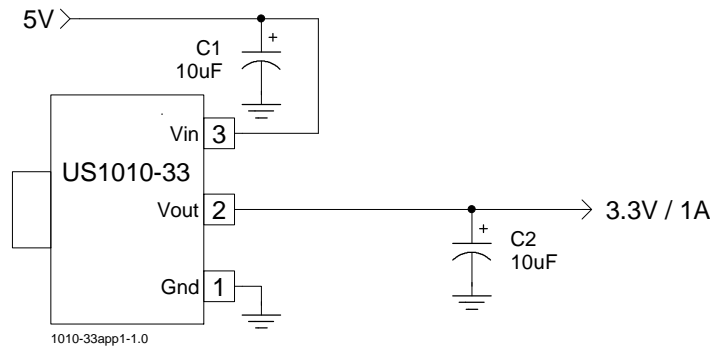

Typical Application of US1010-33 in a 5V to 3.3V regulator .

PACKAGE ORDER INFORMATION

Tj (°C)	2 PIN PLASTIC TO252 (D)	3 PIN PLASTIC SOT223 (Y)	2 PIN PLASTIC POWER FLEX (P)	8 PIN PLASTIC SOIC (S)
0 TO 150	US1010-33CD	US1010-33CY	US1010-33CP	US1010-33CS

US1010-33

ABSOLUTE MAXIMUM RATINGS

Input Voltage (Vin)	7V
Power Dissipation	Internally Limited
Storage Temperature Range	-65°C TO 150°C
Operating Junction Temperature Range	0°C TO 150°C

PACKAGE INFORMATION

2 PIN PLASTIC TO252 (D)	3 PIN PLASTIC SOT223 (Y)	2 PIN POWER FLEX (P)	3 PIN PLASTIC SOT223 (Y)
<p>FRONT VIEW</p> <p>Tab is Vout</p> <p>3 Vin</p> <p>1 Gnd</p> <p>$\theta_{JA}=70^{\circ}\text{C/W}$ for 0.5" Sq pad</p>	<p>TOP VIEW</p> <p>Tab is Vout</p> <p>3 Vin</p> <p>2 Vout</p> <p>1 Gnd</p> <p>$\theta_{JA}=90^{\circ}\text{C/W}$ for 0.4" Sq pad</p>	<p>FRONT VIEW</p> <p>Tab is Vout</p> <p>3 Vin</p> <p>1 Gnd</p> <p>$\theta_{JA}=70^{\circ}\text{C/W}$ for 0.5" Sq pad</p>	<p>TOP VIEW</p> <p>Vin 1 8 Vout</p> <p>NC 2 7 Vout</p> <p>NC 3 6 Vout</p> <p>Gnd 4 5 Vout</p> <p>$\theta_{JA}=55^{\circ}\text{C/W}$ for 1" Sq pad</p>

ELECTRICAL SPECIFICATIONS

Unless otherwise specified, these specifications apply over, $C_{in}=1\mu\text{F}$, $V_{in}=5\text{V}$, $C_{out}=10\mu\text{F}$, and $T_j=0$ to 125°C . Typical values refer to $T_j=25^{\circ}\text{C}$.

PARAMETER	SYM	TEST CONDITION	MIN	TYP	MAX	UNITS
Output Voltage	V_o	$I_o=10\text{mA}$, $T_j=25^{\circ}\text{C}$ $I_o=10\text{mA}$	3.267 3.235	3.300 3.300	3.333 3.365	V
Line Regulation		$I_o=10\text{mA}$, $4.75\text{V} < V_{in} < 7\text{V}$			7	mV
Load Regulation (Note 1)		$10\text{mA} < I_o < 1\text{A}$			17	mV
Dropout Voltage (Note 2)		$I_o=1\text{A}$			1.3	V
Current Limit		$dV_o=100\text{mV}$	1.1			A
Thermal Regulation		30 mS PULSE, $I_o=1\text{A}$		0.01	0.02	%/W
Ripple Rejection		$f=120\text{HZ}$, $C_o=25\mu\text{F}$ Tan $I_o=0.5\text{A}$	60	70		dB
Temperature Stability		$I_o=10\text{mA}$		0.5		%
Long Term Stability		$T_j=125^{\circ}\text{C}$, 1000 Hrs		0.3	1	%
RMS Output Noise		$T_j=25^{\circ}\text{C}$ 10hz< f <10khz		0.003		% V_o

Note 1 : Low duty cycle pulse testing with Kelvin connections are required in order to maintain accurate data.

Note 2 : Drop-out voltage is defined as the minimum differential voltage between V_{in} and V_{out} required to maintain regulation at V_{out} . It is measured when the output voltage drops 1% below its nominal value.

PIN DESCRIPTIONS

PIN#	PIN SYMBOL	Pin Description
1	Gnd	Gnd pin. This pin must be connected to GND plane using a low inductance short connection.
2	Vout	The output of the regulator. This pin is also connected to the tab of the package. An output capacitor must be connected to this pin to insure stability of the regulator.
3	Vin	Input pin of the regulator.

BLOCK DIAGRAM

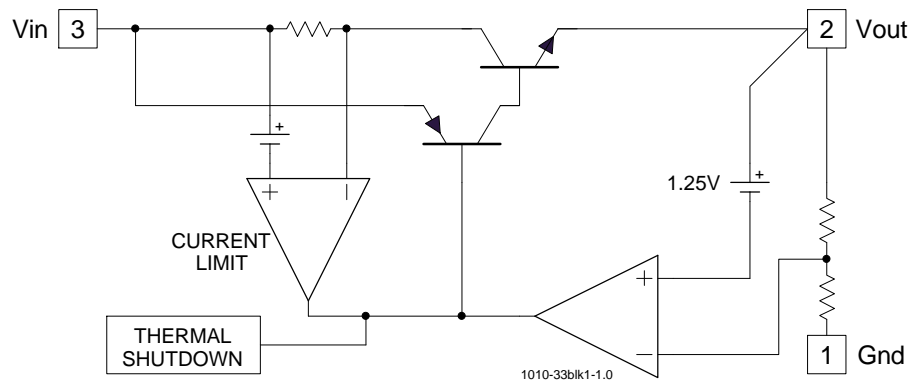

Figure 1 - Simplified block diagram of the US1010-33