

# T-1 PACKAGE NPN PHOTOTRANSISTOR

**MID-38A22**

## Description

The MID-38A22 is a NPN silicon phototransistor mounted in a lensed, special dark plastic package. The lensing effect of the package allows an acceptance half view angle of 20° that is measured from the optical axis to the half power point.

## Features

- Wide range of collector current
- Lensed for high sensitivity
- Special T-1(3mm) package
- Good spectral matching to IRED ( $\lambda_p=940\text{nm}$ ) type.

## Package Dimensions

Unit : mm (inches )

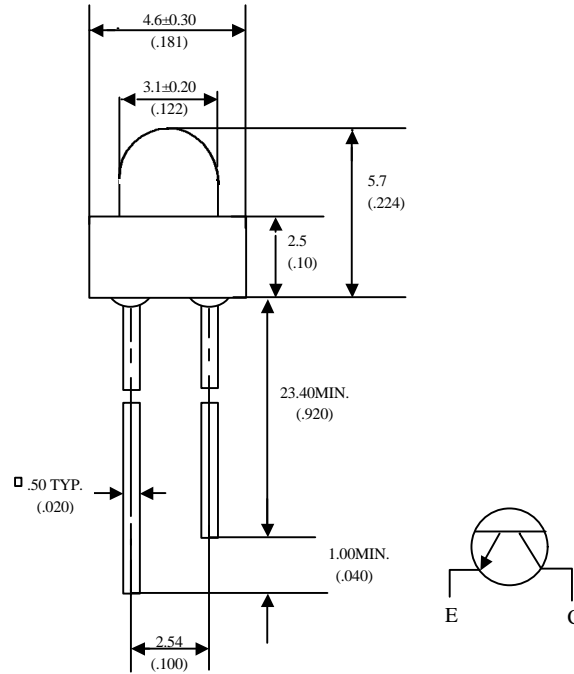

Notes :

1. Tolerance is  $\pm 0.25\text{mm}$  (.010") unless otherwise noted .
2. Protruded resin under flange is 1.5 mm (.059") max
3. Lead spacing is measured where the leads emerge from the package.

## Absolute Maximum Ratings

@  $T_A=25^\circ\text{C}$

Parameter	Maximum Rating	Unit
Power Dissipation	100	mW
Collector-Emitter Voltage	30	V
Emitter-Collector Voltage	5	V
Operating Temperature Range	-55°C to +100°C	
Storage Temperature Range	-55°C to +100°C	
Lead Soldering Temperature	260°C for 5 seconds	

**UNI**

Unity Opto Technology Co., Ltd.

02/04/2002

## Optical-Electrical Characteristics

@ T<sub>A</sub>=25°C

Parameter	Test Conditions	Symbol	Min.	Typ.	Max.	Unit
Collector-Emitter Breakdown Voltage	I <sub>c</sub> =0.1mA E <sub>e</sub> =0	V <sub>(BR)CEO</sub>	30			V
Emitter-Collector Breakdown Voltage	I <sub>e</sub> =0.1mA E <sub>e</sub> =0	V <sub>(BR)ECO</sub>	5			V
Collector-Emitter Saturation Voltage	I <sub>c</sub> =0.5mA E <sub>e</sub> =0.1mW/cm <sup>2</sup>	V <sub>CE(SAT)</sub>			0.4	V
Rise Time	V <sub>CC</sub> =5V, R <sub>L</sub> =1KΩ	T <sub>r</sub>		15		μS
Fall Time	I <sub>C</sub> =1mA	T <sub>f</sub>		15		
Collector Dark Current	V <sub>CE</sub> =10V E <sub>e</sub> =0	I <sub>CEO</sub>			100	nA
On State Collector Current	V <sub>CE</sub> =5V E <sub>e</sub> =0.1mW/cm <sup>2</sup>	I <sub>C(ON)</sub>		0.6		mA

## Typical Optical-Electrical Characteristic Curves

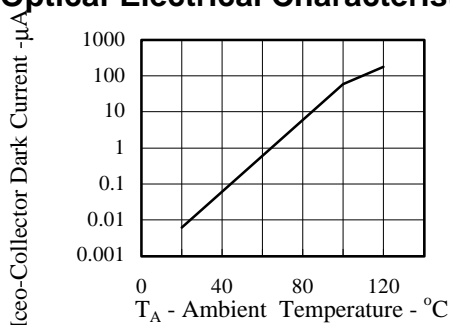

FIG.1 COLLECTOR DARK CURRENT VS AMBIENT TEMPERATURE

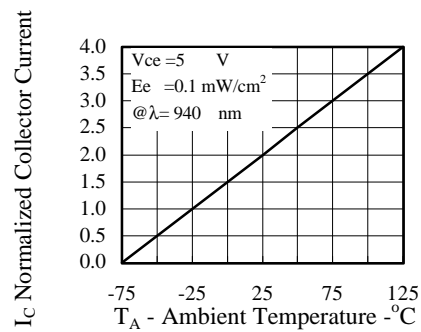

FIG.2 NORMALIZED COLLECTOR CURRENT VS AMBIENT TEMPERATURE

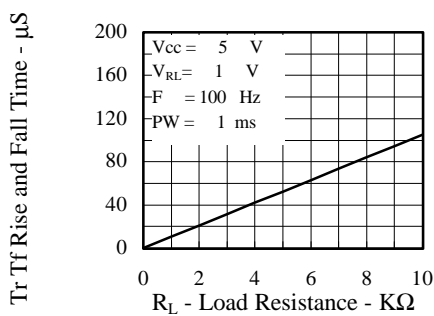

FIG.3 RISE AND FALL TIME VS LOAD RESISTANCE

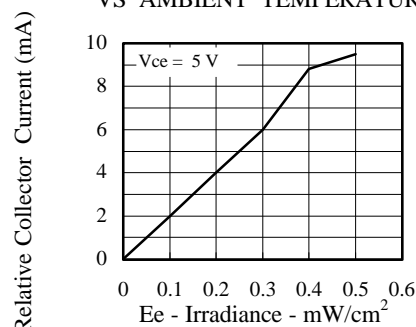

FIG.4 RELATIVE COLLECTOR CURRENT VS IRRADIANCE

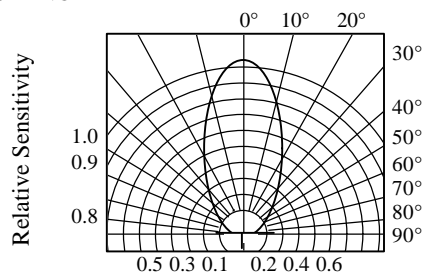

FIG.5 SENSITIVITY DIAGRAM