

## Features

1. Uni-directional data transmission using plastic fiber
2. Signal transmission speed  
:MAX. 13.2Mbps (NRZ signal)
3. Operating voltage :2.75 to 5.25 V
4. TTL and high speed C-MOS LOGIC IC compatible

## Outline Dimensions

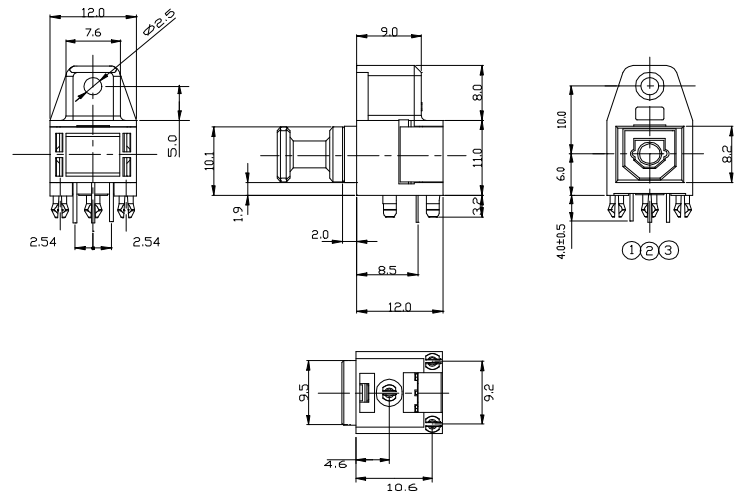

Recommended drilling as viewed from the soldering face

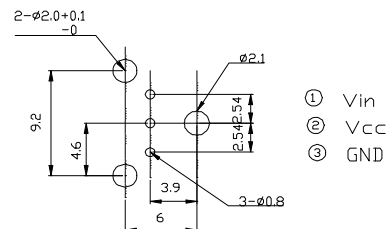

NOTES:

Tolerance is  $\pm 0.3\text{mm}$  unless otherwise noted.

## Absolute Maximum Ratings

@TA=25°C

Parameter	Symbol	Rating	Unit
Supply voltage	$V_{cc}$	-0.5 to + 7.0	V
Input voltage	$V_{in}$	-0.5 to $V_{cc} + 0.5$	V
Operating temperature	$T_{opr}$	-20 to +70	°C
Storage temperature	$T_{stg}$	-30 to +80	°C
Soldering temperature <sup>*1</sup>	$T_{sol}$	260	°C

\*1 For 5s (2 times or less)

**Recommended Operating Conditions**

Parameter	Symbol	MIN.	TYP.	MAX.	Unit
Operating supply voltage	$V_{cc}$	2.75	---	5.25	V
Operating transfer rate	T	---	---	13.2	Mbps

**Electro-Optical Characteristics**

Parameter	Symbol	Conditions	MIN.	TYP.	MAX.	Unit
Peak emission wavelength	$\lambda_p$		630	660	690	nm
Optical power output coupling with fiber	$P_c$	Refer to Fig. 1	-21	-18	-15	dBm
Dissipation current	$I_{cc}$	Refer to Fig. 2	---	8	13	mA
High level input voltage	$V_{iH}$	Refer to Fig. 2	2.1	---	$V_{cc}$	V
Low level input voltage	$V_{iL}$	Refer to Fig. 2	---	---	0.8	V
Low High delay time	$t_{pLH}$	Refer to Fig. 3	---	100	180	ns
High Low delay time	$t_{pHL}$	Refer to Fig. 3	---	100	180	ns
Pulse width distortion	$\Delta_{tw}$	Refer to Fig. 3	-15	---	+15	ns

Fig. 1 Measuring Method of Optical Output Coupling with Fiber

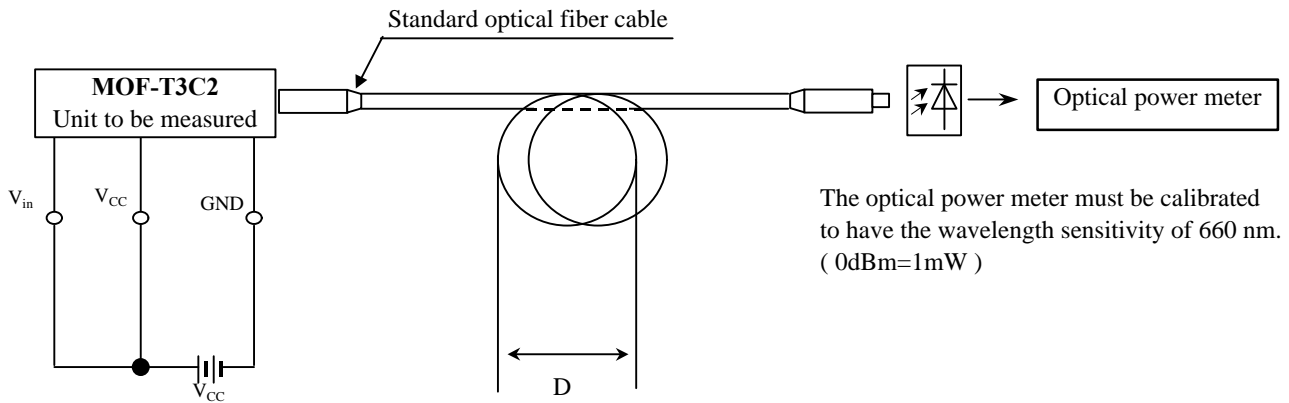

- Notes (1)  $V_{cc}=5.0V$  (State of operating)  
 (2) To bundle up the standard fiber optic cable, make it into a loop with the diameter  $D=10cm$  or more.

Fig. 2 Measuring Method of Input Voltage and Supply Current

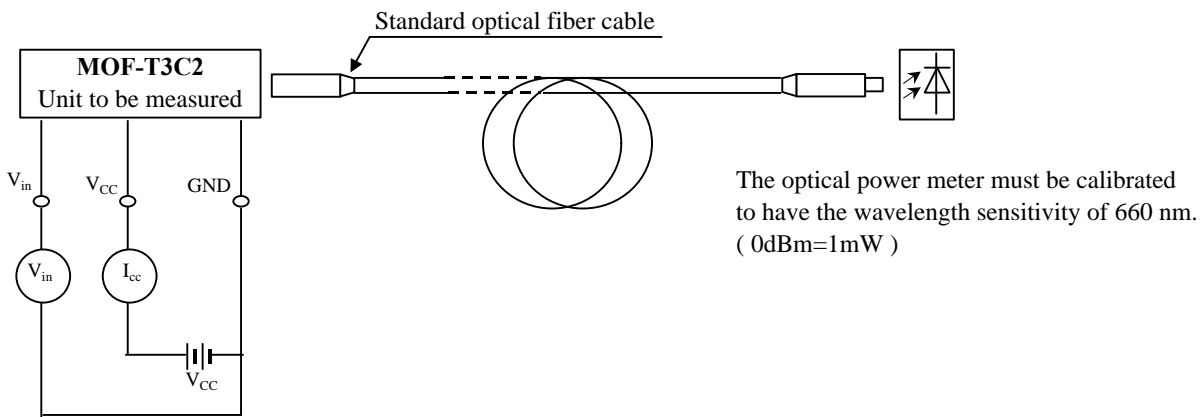

**Input conditions and judgement method**

Conditions	Judgement method
$V_{in}=2.1V$ or more	$-21dBm \leq P_c \leq -15dBm$ , $I_{cc}=13mA$ or less
$V_{in}=0.8V$ or less	$P_c \leq -36dBm$ , $I_{cc}=13mA$ or less

Note:  $V_{cc}=5.0V$  (State of operating)

**Fig.3 Measuring Method of Pulse Response**

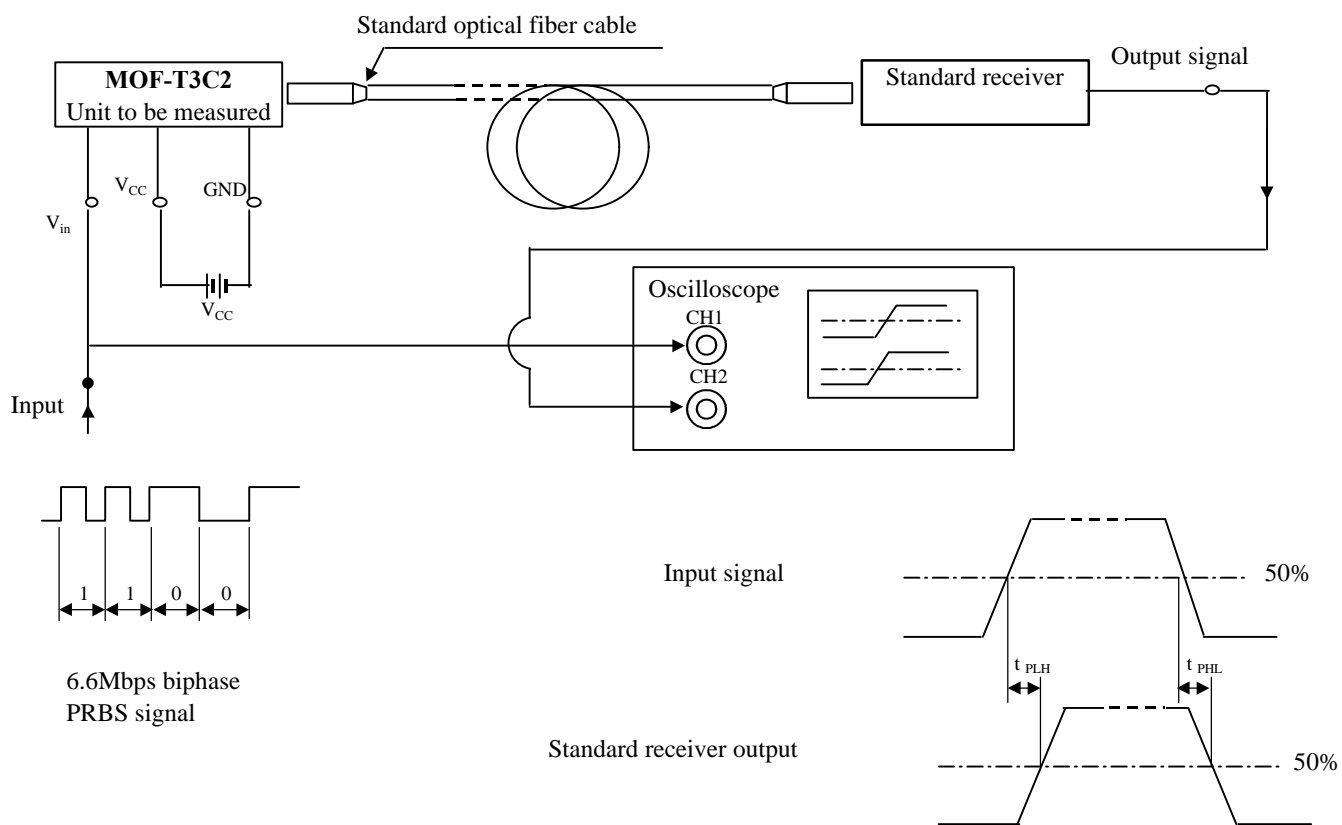

**Test item**

Test item	Symbol	Test condition
Low High pulse delay time	$t_{PLH}$	Refer to the above prescriptions
High Low pulse delay time	$t_{PHL}$	Refer to the above prescriptions
Pulse width distortion	$\Delta t_w$	$\Delta t_w = t_{PHL} - t_{PLH}$

- Notes**
- (1) The waveform write time shall be 4 seconds. But do not allow the waveform to be distorted by increasing the brightness too much.
  - (2)  $V_{cc} = 5.0\text{ V}$  (State of operating)
  - (3) The probe for the oscilloscope must be more than 1M and less than 10pF.