

Transistors

2N6517

HIGH VOLTAGE TRANSISOTR

- Collector-Emitter Voltage: $V_{CE0} = 350V$
- Collector Dissipation: $P_C (max) = 625mW$

ABSOLUTE MAXIMUM RATINGS ($T_a = 25^\circ C$)

Characteristic	Symbol	Rating	Unit
Collector-Base Voltage	V_{CBO}	350	V
Collector-Emitter Voltage	V_{CEO}	350	V
Emitter-Base Voltage	V_{EBO}	6	V
Collector Current	I_C	500	mA
Collector Dissipation	P_C	625	mW
Junction Temperature	T_j	150	$^\circ C$
Storage Temperature	T_{stg}	-55 ~ 150	$^\circ C$

- Refer to 2N6515 for graphs

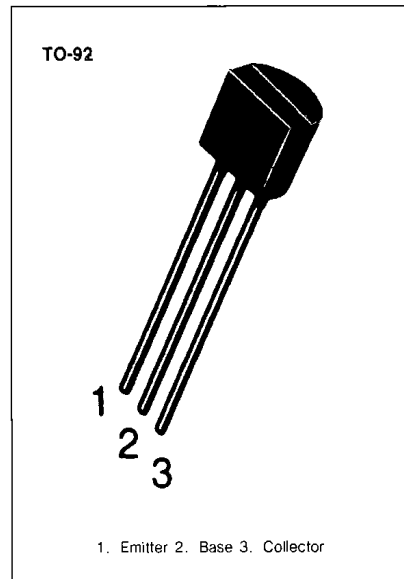

ELECTRICAL CHARACTERISTICS ($T_a = 25^\circ C$)

Characteristic	Symbol	Test Conditions	Min	Typ	Max	Unit
* Collector-Emitter Breakdown Voltage	BV_{CEO}	$I_C = 1mA, I_B = 0$	350			V
Collector-Base Breakdown Voltage	BV_{CBO}	$I_C = 100\mu A, I_E = 0$	350			V
Emitter-Base Breakdown Voltage	BV_{EBO}	$I_E = 10\mu A, I_C = 0$	6			V
Collector Cut-off Current	I_{CBO}	$V_{CB} = 250V, I_E = 0$			50	nA
Emitter Cut-off Current	I_{EBO}	$V_{EB} = 5V, I_C = 0$			50	nA
* DC Current Gain	h_{FE}	$I_C = 1mA, V_{CE} = 10V$	20			
		$I_C = 10mA, V_{CE} = 10V$	30			
		$I_C = 30mA, V_{CE} = 10V$	30		200	
		$I_C = 50mA, V_{CE} = 10V$	20		200	
		$I_C = 100mA, V_{CE} = 10V$	15			
Collector-Emitter Saturation Voltage	$V_{CE} (sat)$	$I_C = 10mA, I_B = 1mA$			0.3	V
		$I_C = 20mA, I_B = 2mA$			0.35	V
		$I_C = 30mA, I_B = 3mA$			0.5	V
		$I_C = 50mA, I_B = 5mA$			1	V
Base-Emitter Saturation Voltage	$V_{BE} (sat)$	$I_C = 10mA, I_B = 1mA$			0.75	V
		$I_C = 20mA, I_B = 2mA$			0.85	V
		$I_C = 30mA, I_B = 3mA$			0.9	V
Collect-Base Capacitance	C_{cb}	$V_{CB} = 20V, I_E = 0$			6	pF
* Current Gain Bandwidth Product	f_T	$f = 1MHz$ $I_C = 10mA, V_{CE} = 20V$	40		200	MHz
Base Emitter On Voltage	$V_{BE} (on)$	$I_C = 100mA, V_{CE} = 10V$			2	V

* Pulse Test: Pulse Width = 300 μs , Duty Cycle = 2%

