

# UTC 51494

# LINEAR INTEGRATED CIRCUIT

## DESCRIPTION

The UTC 51494 is a monolithic bipolar integrate circuit that provides both 494 function and built in power good signal circuit for easy using 51494 can be easily implemented by just adding a capacitor.

## FEATURES

- \*Fully integrated with compact 16-pin dip
- \*All necessary functions included for most popular half bridge circuit.
- \*Built-in power good delay and power fail lead function.
- \*Power good delay time is linearly.
- \*Proportional to external capacitor value.
- \*Reduced external components for cost down and components for cost down and compact size.

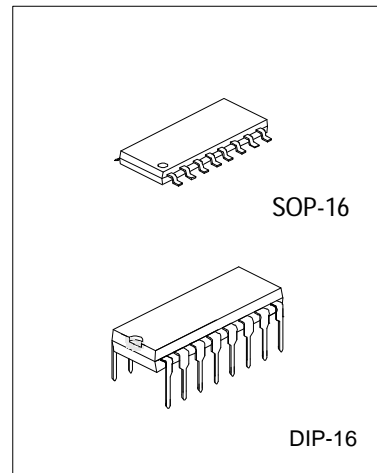

## MAXIMUM RATINGS(Unless otherwise noted ,all is over operating free-air temperature Range)

CHARACTERISTIC	SYMBOL	RATING	UNIT
Supply Voltage	V <sub>cc</sub>	42	V
Voltage from any pin to ground (except pin8 & pin11)	V <sub>in</sub>	V <sub>cc</sub> +0.3	V
Collector Output Voltage	V <sub>c1</sub> , V <sub>c2</sub>	42	V
Peak Collector Output	I <sub>c1</sub> , I <sub>c2</sub>	250	mA
Power dissipation	P <sub>D</sub>	1500	mW
Operating Temperature Range	T <sub>opr</sub>	0 to +70	°C
Storage Temperature Range	T <sub>sag</sub>	-65 to +150	°C

## ELECTRICAL CHARACTERISTICS

(Unless otherwise specified , Ta=0~70°C ,Vcc=15V,f=10kHz,)

PARAMETER	SYMBOL	TEST CONDITIONS	MIN	TYP	MAX	UNIT
<b>Reference Section</b>						
Reference voltage	Vref	Iref =1.0mA	4.75	5	5.25	V
Line Regulation	Vline	7V<Vcc<40V		2	25	mV
Load Regulation	Vload	1mA<Iref<5mA		1	15	mV
Temperature Coefficient		0°C <Fa<70°C		0.01	0.03	%/°C
<b>Oscillator section</b>						
Oscillator Frequency	Fosc	CT=0.01μF,RT=12kΩ		10		kHz
Oscillator Frequency Change Over Operating Temperature Range	Δfosc	CT=0.01μF,RT=12kΩ			2	%
<b>Dead Time Control Section</b>						
Input Bias Current ( Pin 4 )	lib(dt)	Vcc =15V ; 0V<V4<5.25V		-2	-10	μA
Maximum Duty cycle, Each output	Dc(max)	Vcc = 15V; Pin 4 = 0V Output Control Pin = Vref	43		45	%
Input Threshold Voltage : Zero Duty Max Duty	Vth		0	3	3.3	V
<b>Error Amplifier Section</b>						
Input offset Voltage	Vics	V3=2.5V		2	10	mV
Input offset Current	Iics	V3=2.5V		25	250	nA
Input bias Current	lib	V3=2.5V		0.2	1	μA
Input Common-mode Voltage Range	Vicr	7V <Vcc< 40V	-0.3		Vcc	V
Large Signal Open-Loop Voltage Range	Gvo	0.5V < V3 < 3.5V	60	74		dB
Unity-Gain Band width	fc			650		kHz
<b>Output Section</b>						
Collector off-state current	Ic(off)	VCC=VC=40V,VE=0		2	100	μA
Emitter off-state Current	Ie(off)	VCC=VC=40V,VE=0			-100	μA
Output Saturation Voltage Common-Emitter	Vce(sat)	VE=15V,Lc=200mA		1.1	1.3	V
<b>Output Control (pin13)</b>						
Standby Power Supply Current	Icc			6	10	mA
<b>Output AC Characteristic</b>						
Raise Time Common-Emitter	Tr			100	200	ns
Fall Time Common-Emitter	Tr			25	100	ns
<b>PWM Comparator Section</b>						
Inhibit Threshold Voltage	Vthi	Zero Duty cycle		4	4.5	V
Output Source Current	Io+	0.5V < V3 < 3.5V	2			mA
Output Sink Current	Io-	0.5V < V3 < 3.5V	-0.2	-0.6		mA

PARAMETER	SYMBOL	TEST CONDITIONS	MIN	TYP	MAX	UNIT
<b>Power Good Section</b>						
Power Good Delay Time	tpd	Cd = 1 $\mu$	230	280	330	ms
		Cd = 0.47 $\mu$	108	130	160	
Power Fail Lead Time	Tp1			4		ms
Output High Voltage	Voh	Vpinn = 5V, IL = 1mA	4.75			V
Output Saturation Voltage	Vsat	Vpinn = 5V, Isink = 4mA			0.4	V
Output Leakage Current	Ioh				100	$\mu$ A

## PIN DESCRIPTION

PIN	NAME	FUNCTION
1	EA1+	Error amplifier noninverting input, same as pin 1 of 494
2	EA1-	Error amplifier inverting input, same as pin 2 of 494
3	EA0	Error amplifier output and feedback, same as pin 3 of 494
4	DT	Dead time control input, same as pin 4 of 494
5	CT	Connect capacitor to oscillator circuit for operating frequency, same as pin 5 of 494
6	RT	Connect resistor to oscillator circuit for operating frequency, same as pin 6 of 494
7	GND	Ground terminal of IC, same as pin 7 of 494
8	C1	Collector of output transistor one, same as pin 8 of 494
9	GND	Ground terminal of IC
10	Cpg	Terminal for capacitor to determine power good delay time
11	C2	Collector of output transistor two, same as pin 11 of 494
12	Vcc	Supply voltage, same as pin 12 of 494
13	P.G.	Output for power good signal
14	Vref	Reference voltage output, same as pin 14 of 494
15	EA2-	Error amplifier inverting input, same as pin 15 of 494
16	EA+	Error amplifier noninverting input, same as pin 16 of 494

BLOCK DIAGRAM

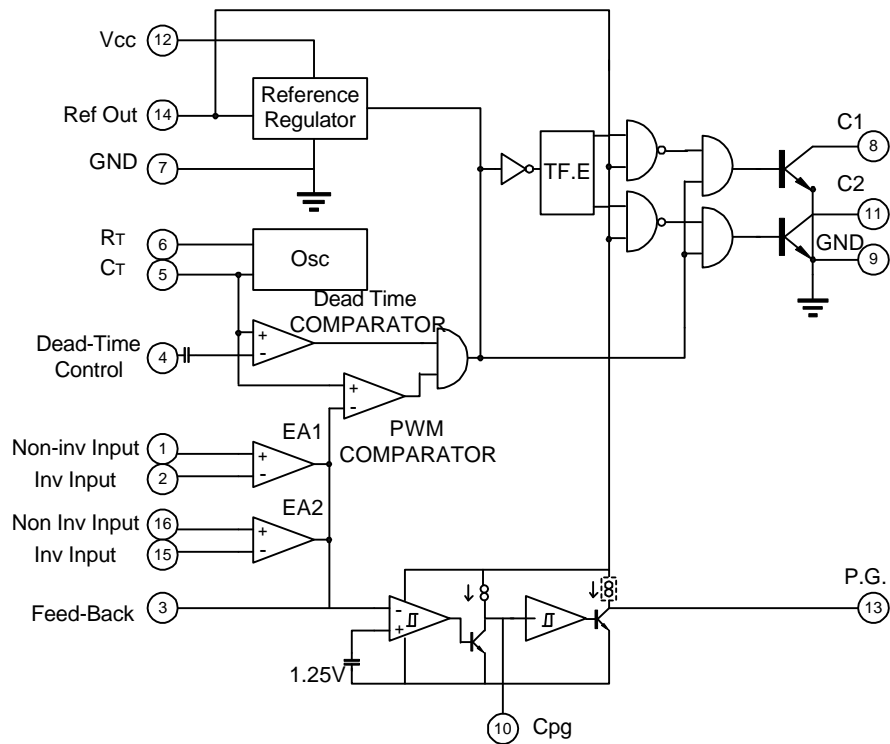

# UTC51494

# LINEAR INTEGRATED CIRCUIT

