

UTC UC723 LINEAR INTEGRATED CIRCUIT

ADJUSTABLE VOLTAGE REGULATOR

DESCRIPTION

The UTC UC723 is a silicon monolithic integrated circuit, designed for service as voltage regulator at output voltages, ranging from 2V to 37V at current up to 150mA. It includes a temperature-compensated reference amplifier, an error amplifier, a power series pass transistor, and a current-limiting circuit.

FEATURES

- *Up to 150mA output current
- *Adjustable output voltage (from 2V to 37V)
- *Positive and negative voltage regulation
- *Regulation in excess of 10A with suitable pass transistors
- *Input and output short-circuit protection
- *Load and line regulation < 0.03%

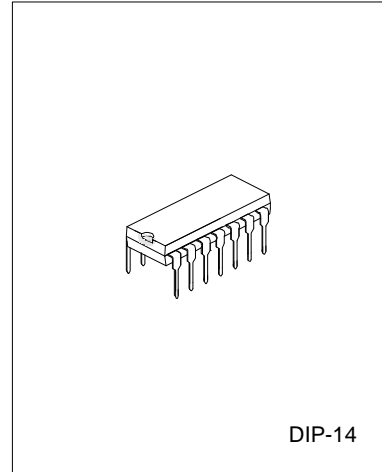

BLOCK DIAGRAM

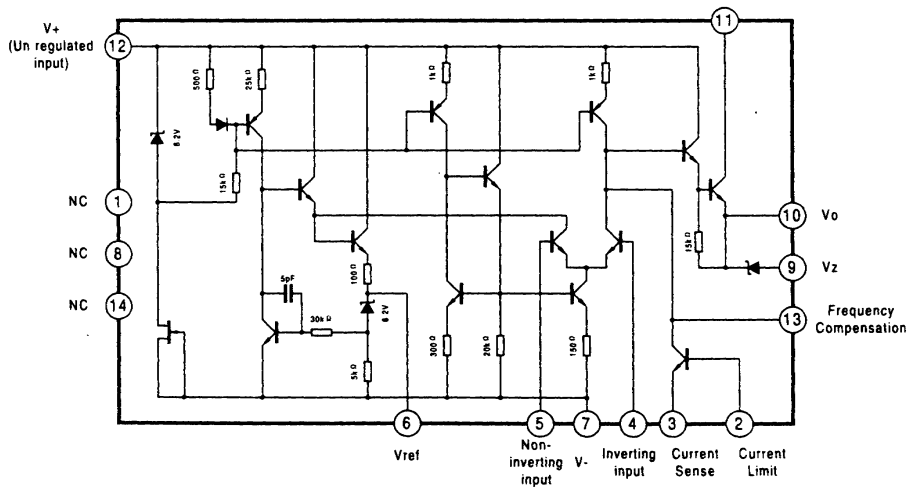

ABSOLUTE MAXIMUM RATINGS(Ta=25°C)

PARAMETER	SYMBOL	VALUE	UNIT
Supply Voltage(between V+ and V-)	Vcc	40	V
Pulse Voltage for 50ms	Vpulse	50	V
Differential Input-Output Voltage	Vd	40	V
Different Input Voltage (Between inverting and non-inverting inputs)	Vid	+5	V
Different Input Voltage (Between Non-inverting Input and V-)	Vid	8	V
Current from Zener Diode Terminal	Iz	25	mA
Power Dissipation	Pd	900	mW
Operating Temperature	Topr	-55 ~ 125	°C
Storage Temperature	Tstr	-65 ~ 150	°C

ELECTRICAL CHARACTERISTICS(Ta=25°C, V+=Vc=Vi=12V, Vo=5V, IL=1mA, C1=100Pf, Cref=0, Rscp=0, unless otherwise specified, divider impedance $R1 \cdot R2 / (R1 + R2)$ at non-inverting input, terminal 5=10KΩ)

PARAMETER	SYMBOL	TEST CONDITIONS	MIN	TYP	MAX	UNIT
Quiescent Regulator Current	ICQ	IL=0, VI=30V		2.3	3.5	mA
Input Voltage Range	VI		9.5		40	V
Output Voltage Range	VO		2		37	V
Differential Input-Output Voltage	VI-VO		3		38	V
Reference Voltage	VREF		6.95	7.15	7.35	V
Line Regulation (note 1)	ΔVO	VI=12V to 40V VI=12V to 15V VI=12V to 15V, Ta=-55~125°C		0.02 0.01	0.2 0.1	%Vo
Load Regulation (note 1)	ΔVO	IL=1mA TO 50mA IL=1mA TO 50mA, Ta=-55~125°C		0.03	0.15 0.6	%Vo
Output Voltage Temperature Coefficient	ΔVO	Ta=-55~125°C		0.002	0.015	%/°C
Ripple Rejection (note 2)	RR	f=50Hz to 10KHz f=50Hz to 10KHz, Cref=5μF Tmin<Ttyp<Tmax		74 86 2.5		dB
Short Circuit Limiting Current	ILIM	Rscp=10Ω, Vo=0		65		mA
Equivalent Noise RMS output Voltage (note 2)	VN	BW=100Hz to 10KHz, Cref=0 BW=100Hz to 10KHz, Cref=5μF		-20 2.5		μV

NOTE 1: Line and load regulation specifications are given for conditions of a constant chip temperature. For high dissipation condition, temperature drifts must be separately taken in account.

NOTE 2: For Cref, see Fig. 1

UTC UC723 LINEAR INTEGRATED CIRCUIT

APPLICATION CIRCUIT

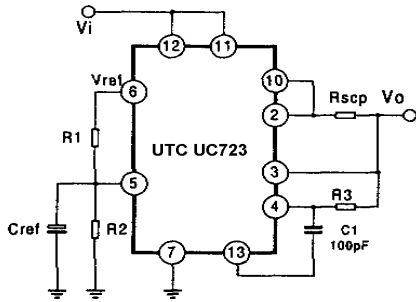

Regulator Output Voltage=5V
 Line Regulation ($\Delta V_i=3V$)=0.5mV
 Load regulation ($\Delta I_L=50mA$)=1.5mV
 Note $R_3=R_1 \cdot R_2 / (R_1 + R_2)$ for Minimum temperature drift

Fig. 1 Low Voltage Regulator circuit($V_o=2V$ to $7V$)

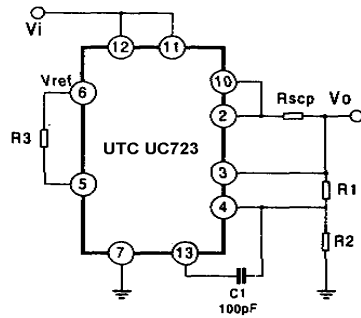

Regulator Output Voltage=5V
 Line Regulation ($\Delta V_i=3V$)=1.5mV
 Load regulation ($\Delta I_L=50mA$)=4.5mV
 Note $R_3=R_1 \cdot R_2 / (R_1 + R_2)$ for Minimum temperature drift

Fig. 2 High Voltage Regulator circuit($V_o=7V$ to $37V$)

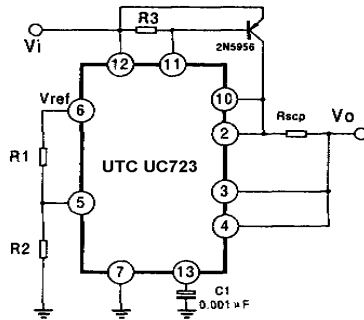

Regulator Output Voltage=5V
 Line Regulation ($\Delta V_i=3V$)=0.5mV
 Load regulation ($\Delta I_L=1A$)=5mV

Fig. 3 Positive Voltage regulator Circuit
 (with external p-n-p pass transistor)

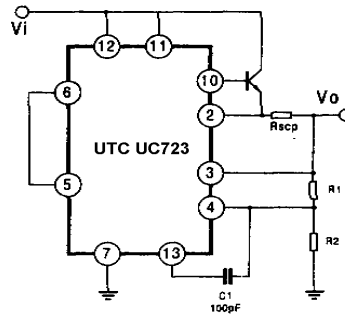

Regulator Output Voltage=15V
 Line Regulation ($\Delta V_i=3V$)=1.5mV
 Load regulation ($\Delta I_L=1A$)=15mV

Fig. 4 Positive Voltage regulator Circuit
 (with external n-p-n pass transistor)

TYPICAL PERFORMANCE CHARACTERISTICS

