

# UT54LVDM228 Quad 2x2 400 Mbps Crosspoint Switch



## FEATURES

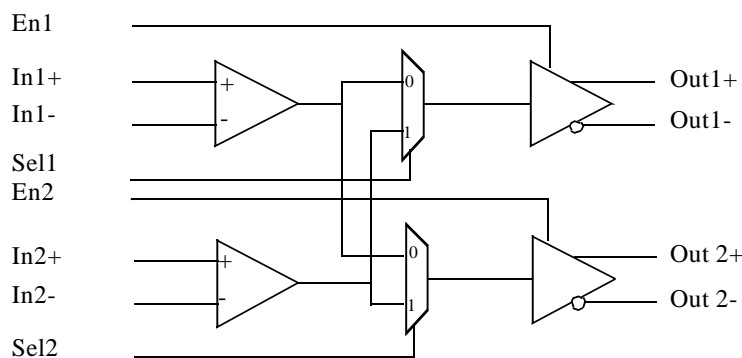
- ❑ 400.0 Mbps low jitter fully differential data path
- ❑ 200MHz clock channel
- ❑ 3.3 V power supply
- ❑ 10mA LVDS output drivers
- ❑ Input receiver fail-safe
- ❑ Cold sparing all pins
- ❑ Output channel-to-channel skew is 120ps max
- ❑ Configurable as quad 2:1 mux, 1:2 demux, repeater or 1:2 signal splitter
- ❑ Fast propagation delay of 3.5ns max
- ❑ Receiver input threshold  $< \pm 100$  mV
- ❑ Radiation-hardened design; total dose irradiation testing to MIL-STD-883 Method 1019
  - Total-dose: 300 krad(Si) and 1 Mrad(Si)
  - Latchup immune (LET > 100 MeV-cm<sup>2</sup>/mg)
- ❑ Packaging options:
  - 64-lead flatpack
- ❑ Standard Microcircuit Drawing 5962-01537
  - QML Q and V compliant part
- ❑ Compatible with ANSI/TIA/EIA 644-1995 LVDS Standard

## INTRODUCTION

The UT54LVDM228 is a quad 2x2 crosspoint switch utilizing Low Voltage Differential Signaling (LVDS) technology for low power, high speed operation. Data paths are fully differential from input to output for low noise generation and low pulse width distortion. The non-blocking design allows connection of any input to any output or outputs on each switch. LVDS I/O enable high speed data transmission for point-to point or multi-drop interconnects. This device can be used as a high speed differential crosspoint, 2:1 mux, 1:2 demux, repeater or 1:2 signal splitter. The mux and demux functions are useful for switching between primary and backup circuits in fault tolerant systems. The 1:2 signal splitter and 2:1 mux functions are useful for distribution of a bus across several rack-mounted backplanes.

The individual LVDS outputs can be put into **Tri-State** by use of the enable pins.

All pins have Cold Spare buffers. These buffers will be high impedance when  $V_{DD}$  is tied to  $V_{SS}$ .



**Figure 1a. UT54LVDM228 Crosspoint Switch Block Diagram (Partial - see Page 2 for complete diagram)**

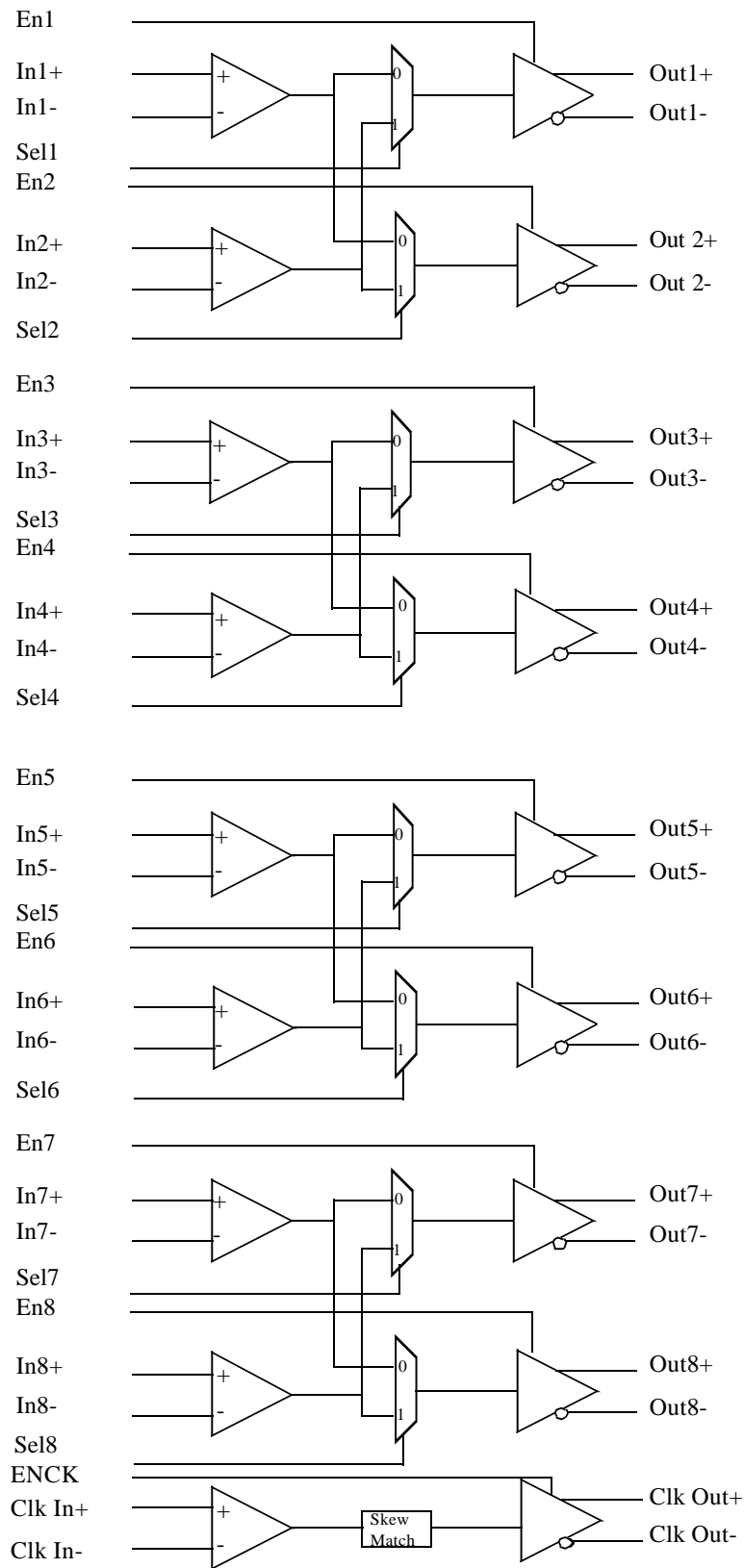


Figure 1b. UT54LVDM228 Crosspoint Switch Block Diagram

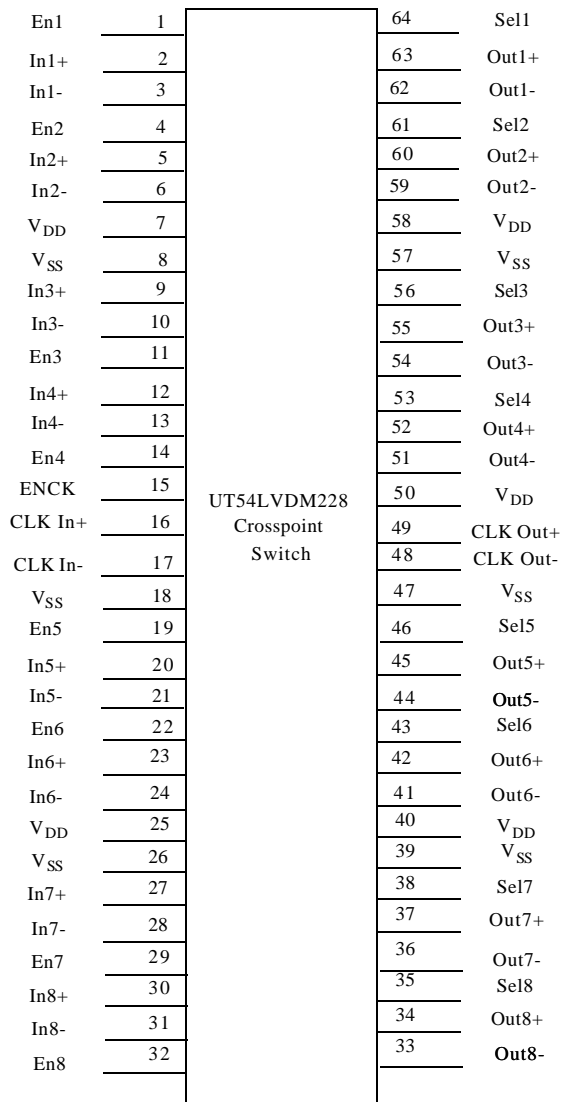


Figure 2. UT54LVDS228 Pinout

### TRUTH TABLE

Sel1	Sel2	Out1	Out2	Mode
0	0	In1	In1	1:2 splitter
0	1	In1	In2	Repeater
1	0	In2	In1	Switch
1	1	In2	In2	1:2 splitter

### PIN DESCRIPTION

Name	# of Pins	Description
In+	8	Non-inverting LVDS input
In-	8	Inverting LVDS input
Out+	8	Non-inverting LVDS output
Out-	8	Inverting LVDS Output
En	8	A logic low on the enable puts the LVDS output into Tri-State and reduces the supply current
ENCK	1	A logic low on the enable puts the LVDS output into Tri-State and reduces the supply current
Sel	8	2:1 mux input select
V <sub>SS</sub>	6	Ground
V <sub>DD</sub>	5	Power supply
CLK In+	1	Non-Inverting Clock LVDS Input
CLK In-	1	Inverting clock LVDS Input
CLK Out+	1	Non-Inverting Clock LVDS Output
CLK Out-	1	Inverting Clock LVDS Output

## APPLICATIONS INFORMATION

The UT54LVDM228 provides three modes of operation. In the 1:2 splitter mode, the two outputs are copies of the same single input. This is useful for distribution / fan-out applications. In the repeater mode, the device operates as a 9channel LVDS buffer. Repeating the signal restores the LVDS amplitude, allowing it to drive another media segment. This allows for isolation of segments or long distance applications or buffers standard LVDS to 10mA multi-op drivers. The switch mode provides a crosspoint function. This can be used in a system when primary and redundant paths are supported in a fault tolerant application.

The intended application of these devices and signaling technique is for both point-to-point baseband (single termination) and multipoint (double termination) data transmissions over controlled impedance media. The transmission media may be printed-circuit board traces, backplanes, or cables. (Note: The ultimate rate and distance of data transfer is dependent upon the attenuation characteristics of the media, the noise coupling to the environment, and other application specific characteristics.

### Input Fail-Safe:

The UT54LVDM228 also supports OPEN, shorted and terminated input fail-safe. Receiver output will be HIGH for all fail-safe conditions.

### PCB layout and Power System Bypass:

Circuit board layout and stack-up for the UT54LVDM228 should be designed to provide noise-free power to the device. Good layout practice also will separate high frequency or high level inputs and outputs to minimize unwanted stray noise pickup, feedback and interference. Power system performance may be greatly improved by using thin dielectrics (4 to 10 mils) for power/ground sandwiches. This increases the intrinsic capacitance of the PCB power system which improves power supply filtering, especially at high frequencies, and makes the value and placement of external bypass capacitors less critical. External bypass capacitors should include both RF ceramic and tantalum electrolytic types. RF capacitors may use values in the range 0.01 $\mu$ F to 0.1 $\mu$ F. Tantalum capacitors may be in the range of 2.2 $\mu$ F to 10 $\mu$ F. Voltage rating for tantalum capacitors should be at least 5X the power supply voltage being used. It is recommended practice to use two vias at each power pin of the UT54LVDM228, as well as all RF bypass capacitor terminals. Dual vias reduce the interconnect inductance and extends the effective frequency range of the bypass components.

The outer layers of the PCB may be flooded with additional ground plane. These planes will improve shielding and isolation, as well as increase the intrinsic capacitance of the power supply plane system. Naturally, to be effective, these planes must be tied to the ground supply plane at frequent intervals with vias. Frequent via placement also improves signal integrity in signal transmission lines by providing short paths for image currents which reduces signal distortion. The planes should be pulled back from all transmission lines and component mounting pads a distance equal to the width of the widest transmission line from the internal power or ground plane(s) whichever is greater. Doing so minimizes effects on transmission line impedances and reduces unwanted parasitic capacitances at component mounting pads.

### Compatibility with LVDS standard:

In backplane multidrop configurations, with closely spaced loads, the effective differential impedance of the line is reduced. If the mainline has been designed for 50 $\Omega$  differential impedance, the loading effects may reduce this to the 35 $\Omega$  range depending upon spacing and capacitance load. Terminating the line with a 35 $\Omega$  load is a better match than with 50 $\Omega$  and reflections are reduced.

## ABSOLUTE MAXIMUM RATINGS<sup>1</sup>

(Referenced to  $V_{SS}$ )

SYMBOL	PARAMETER	LIMITS
$V_{DD}$	DC supply voltage	-0.3 to 4.0V
$V_{I/O}$ <sup>4</sup>	Voltage on any pin	-0.3 to ( $V_{DD} + 0.3V$ )
$T_{STG}$	Storage temperature	-65 to +150°C
$P_D$	Maximum power dissipation	800mW
$T_J$	Maximum junction temperature <sup>2</sup>	+150°C
$\Theta_{JC}$	Thermal resistance, junction-to-case <sup>3</sup>	22°C/W
$I_I$	DC input current	±10mA

### Notes:

1. Stresses outside the listed absolute maximum ratings may cause permanent damage to the device. This is a stress rating only, and functional operation of the device at these or any other conditions beyond limits indicated in the operational sections of this specification is not recommended. Exposure to absolute maximum rating conditions for extended periods may affect device reliability and performance.
2. Maximum junction temperature may be increased to +175°C during burn-in and life test.
3. Test per MIL-STD-883, Method 1012.
4. For Cold Spare mode ( $V_{DD}=V_{SS}$ ),  $V_{I/O}$  may be -0.3V to the maximum recommended operating  $V_{DD} + 0.3V$ .

## RECOMMENDED OPERATING CONDITIONS

SYMBOL	PARAMETER	LIMITS
$V_{DD}$	Positive supply voltage	3.3 to 3.6V
$T_C$	Case temperature range	-55 to +125°C
$V_{IN}$	DC input voltage, receiver inputs	0 to 2.4V
	DC input voltage, logic inputs	0 to $V_{DD}$ for EN, SEL

### DC ELECTRICAL CHARACTERISTICS <sup>1</sup>

( $V_{DD} = 3.3V \pm 0.3V$ ;  $-55^{\circ}C < T_C < +125^{\circ}C$ )

SYMBOL	PARAMETER	CONDITION	MIN	MAX	UNIT
<b>CMOS/TTL DC SPECIFICATIONS (EN, SEL)</b>					
$V_{IH}$	High-level input voltage		2.0	$V_{CC}$	V
$V_{IL}$	Low-level input voltage		GND	0.8	V
$I_{IH}$	High-level input current	$V_{IN}=3.6V$ ; $V_{DD} = 3.6V$	-10	+10	$\mu A$
$I_{IL}$	Low-level input current	$V_{IN}=0V$ ; $V_{DD} = 3.6V$	-10	+10	$\mu A$
$V_{CL}$	Input clamp voltage	$I_{CL}=-18mA$		-1.5	V
$I_{CS}$	Cold Spare Leakage	$V_{IN}=3.6V$ , $V_{DD}=V_{SS}$	-20	+20	$\mu A$
<b>LVDS OUTPUT DC SPECIFICATIONS (OUT+, OUT-)</b>					
$V_{OD}$	Differential Output Voltage	$R_L = 35\Omega$ (see Figure 10)	250	450	mV
$\Delta V_{OD}$	Change in $V_{OD}$ between complimentary output states	$R_L = 35\Omega$		35	mV
$V_{OS}$	Offset Voltage	$R_L = 35\Omega$ $V_{OS} = \frac{(V_{OH} + V_{OL})}{2}$ (see Figure 10)	1.055	1.550	V
$\Delta V_{OS}$	Change in $V_{OS}$ between complimentary output states	$R_L = 35\Omega$		35	mV
$I_{OZ}$	Output Tri-State Current	Tri-State output, $V_{DD} = 3.6V$ $V_{OUT} = V_{DD}$ or GND		$\pm 10$	$\mu A$
$I_{CSOUT}$	Cold Sparing Leakage Current	$V_{OUT}=3.6V$ , $V_{DD}=V_{SS}$	-20	+20	$\mu A$
$I_{OS}^{2,3}$	Output Short Circuit Current	$V_{OUT+}$ OR $V_{OUT-} = 0V$		-25	mA
<b>LVDS RECEIVER DC SPECIFICATIONS (IN+, IN-)</b>					
$V_{TH}^3$	Differential Input High Threshold	$V_{CM} = +1.2V$		+100	mV
$V_{TL}^3$	Differential Input Low Threshold	$V_{CM} = +1.2V$	-100		mV
$V_{CMR}$	Common Mode Voltage Range	$V_{ID}=200mV$	0.2	2.00	V
$I_{IN}$	Input Current	$V_{IN} = +2.4V$ , $V_{DD} = 3.6V$	-10	+10	$\mu A$
		$V_{IN} = 0V$ , $V_{DD} = 3.6V$	-10	+10	$\mu A$
$I_{CSIN}$	Cold Sparing Leakage Current	$V_{IN}=3.6V$ , $V_{DD}=V_{SS}$	-20	+20	$\mu A$
<b>Supply Current</b>					
$I_{CCD}$	Total Supply Current	$R_L = 35\Omega$ EN1 - EN8, ENCK = $V_{DD}$		220	ma
$ICCZ$	Tri-State Supply Current	EN1 - EN8, ENCK = $V_{SS}$		20	ma

**Notes:**

1. Current into device pins is defined as positive. Current out of device pins is defined as negative. All voltages are referenced to ground.
2. Output short circuit current ( $I_{OS}$ ) is specified as magnitude only, minus sign indicates direction only. Only one output should be shorted at a time, do not exceed maximum junction temperature specification.
3. Guaranteed by characterization.

### AC SWITCHING CHARACTERISTICS

( $V_{DD} = +3.3V \pm 0.3V$ ,  $T_A = -55\text{ }^\circ\text{C}$  to  $+125\text{ }^\circ\text{C}$ )

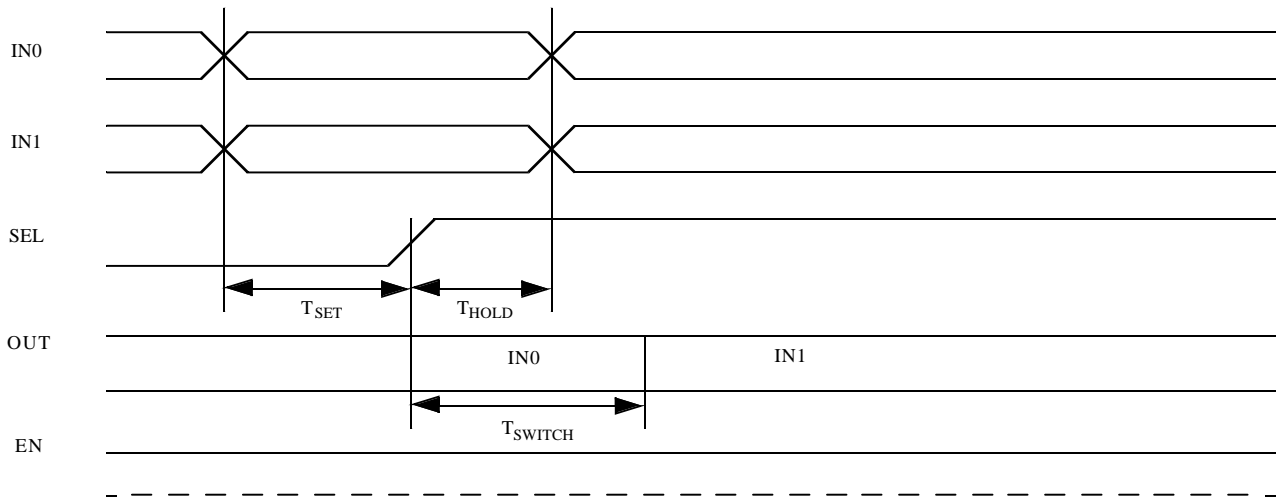
SYMBOL	PARAMETER	Conditions	MIN	MAX	UNIT
$t_{SET}^{1,2}$	Input to SEL Setup Time (Figure 3 & 4)	$R_L=35\Omega$ , $C_L=10\text{pf}$	1.6		ns
$t_{HOLD}^{1,2}$	Input to SEL Hold Time (Figure 3 & 4)	$R_L=35\Omega$ , $C_L=10\text{pf}$	1.5		ns
$t_{SWITCH}^1$	SEL to Switched Output (Figure 3 & 4)	$R_L=35\Omega$ , $C_L=10\text{pf}$		3.0	ns
$t_{PHZ}^1$	Disable Time (Active to Tri-State) High to Z (Figure 5 & 8)	$R_L=35\Omega$ , $C_L=10\text{pf}$		4.5	ns
$t_{PLZ}^1$	Disable Time (Active to Tri-State) Low to Z (Figure 5 & 8)	$R_L=35\Omega$ , $C_L=10\text{pf}$		4.5	ns
$t_{PZH}^{1,4}$	Enable Time (Tri-State to Active) Z to High (Figure 5 & 8)	$R_L=35\Omega$ , $C_L=10\text{pf}$ EN on other channels = GND		11.0	ns
$t_{PZL}^{1,4}$	Enable Time (Tri-State to Active) Z to Low (Figure 5 & 8)	$R_L=35\Omega$ , $C_L=10\text{pf}$ EN on other channels = GND		11.0	ns
$t_{LHT}^3$	Output Low-to-High Transition Time, 20% to 80% (Figure 5 & 6)	$R_L=35\Omega$ , $C_L=10\text{pf}$		600	ps
$t_{HLT}^3$	Output High-to-Low Transition Time, 80% to 20% (Figure 5 & 6)	$R_L=35\Omega$ , $C_L=10\text{pf}$		600	ps
$t_{PLHD}$	Propagation Low to High Delay (Figure 5 & 7)	$R_L=35\Omega$ , $C_L=10\text{pf}$		3.5	ns
$T_{PHLD}$	Propagation High to Low Delay (Figure 5 & 7)	$R_L=35\Omega$ , $C_L=10\text{pf}$		3.5	ns
$T_{SKEW}$	Pulse Skew $T_{PHLD} - T_{PLHD}$ (Figure 5 & 7)			900	ps
$T_{CCS}$	Output Channel-to-Channel Skew (Figure 5 & 9)			500	ps

**Notes:**

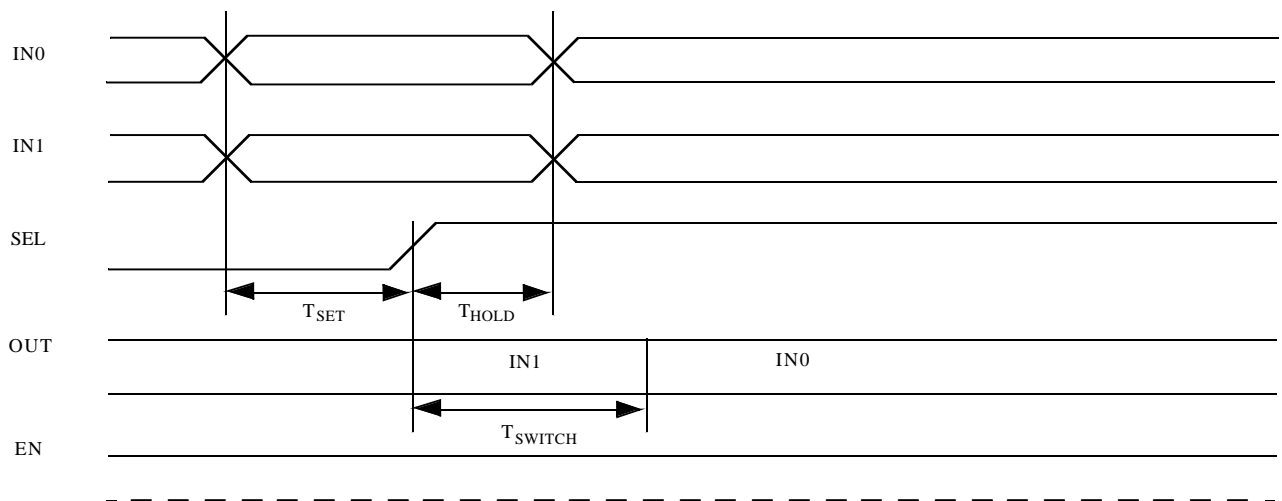
1. Guaranteed by characterization.
2.  $T_{SET}$  and  $T_{HOLD}$  time specify that data must be in a stable state before and after SEL transition.
3. Guaranteed by design.
4. Max  $t_{PZH}$  and  $t_{PZL} = 4.5\text{ns}$  when EN or ENCL =  $V_{DD}$  on another channel.



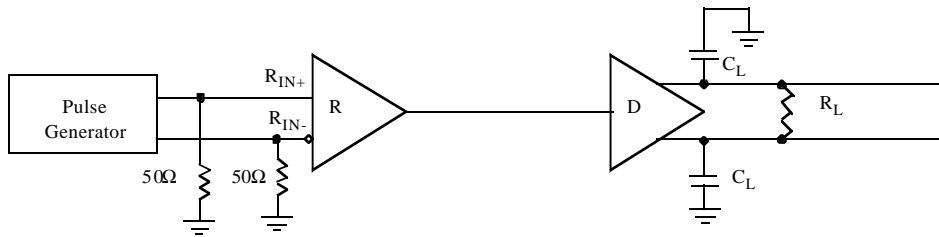
**AC TIMING DIAGRAMS**



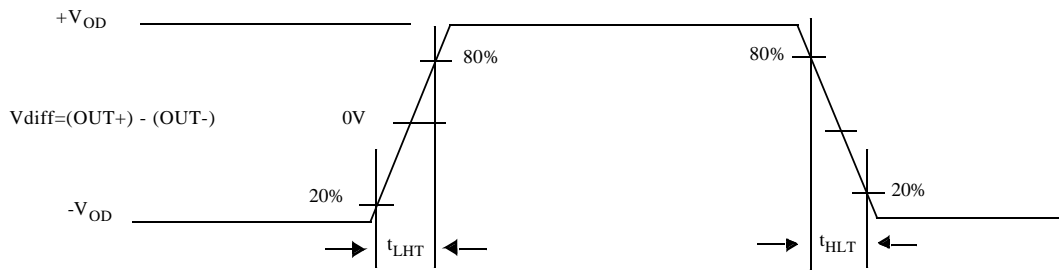
**Figure 3. Input-to-Select Rising Edge Setup and Hold Times and Mux Switch Time**



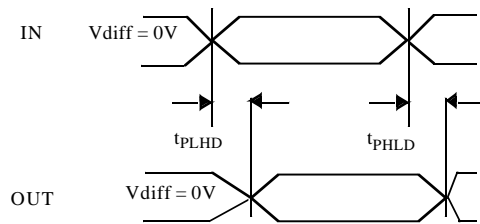
**Figure 4. Input-to-Select Falling Edge Setup and Hold Times and Mux Switch Time**



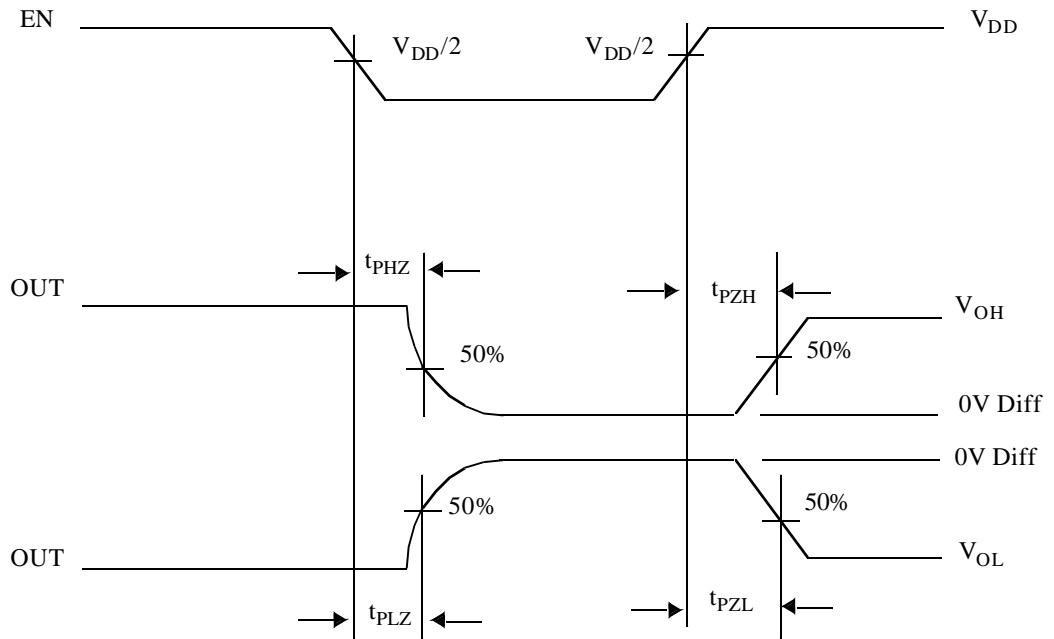
**Figure 5. LVDS Output Load**



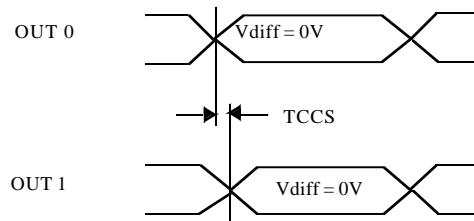
**Figure 6. LVDS Output Transition Time**



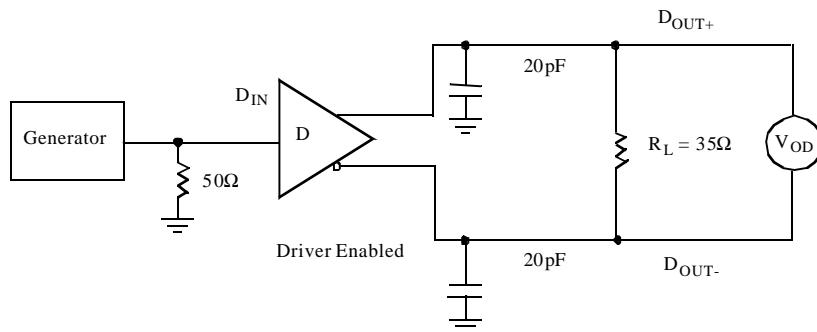
**Figure 7. Propagation Delay Low-to-High and High-to-Low**



**Figure 8. Output active to TRI-STATE and TRI-STATE to active**

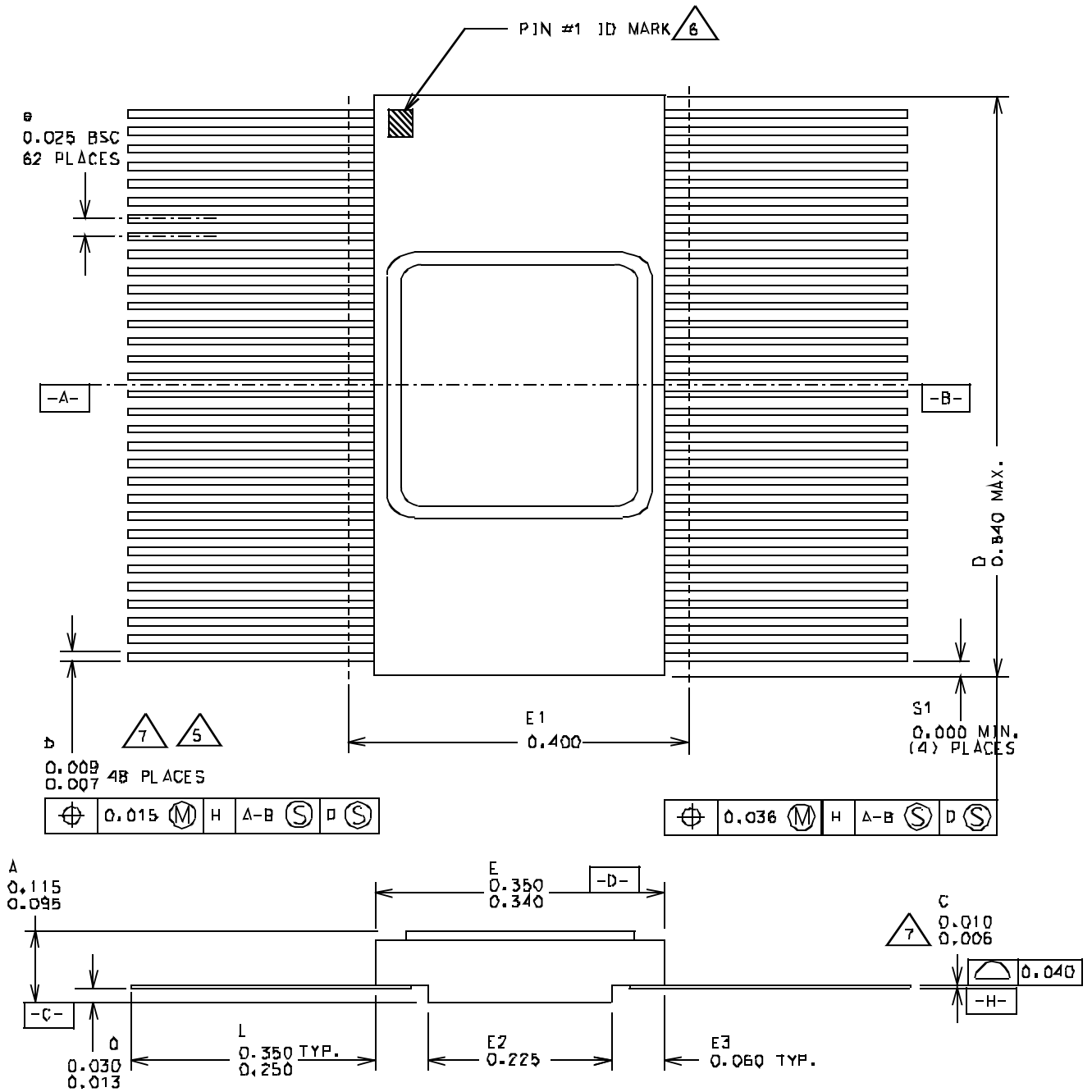


**Figure 9. Output Channel-to-Channel Skew in 1:2 splitter mode**



**Figure 10. Driver  $V_{OD}$  and  $V_{OS}$  Test Circuit or Equivalent Circuit**

# PACKAGING



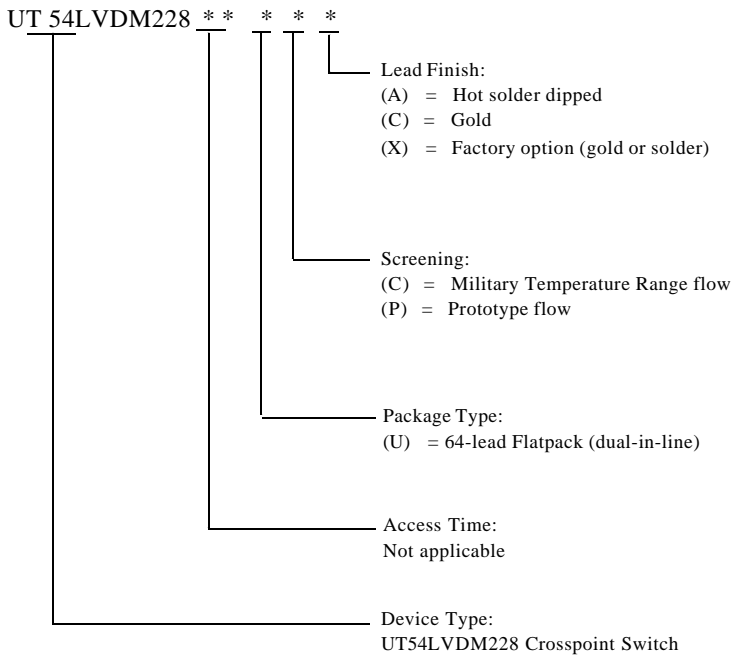
## Notes:

1. All exposed metalized areas are gold plated over electroplated nickel per MIL-PRF-38535.
2. The lid is electrically connected to VSS.
3. Lead finishes are in accordance to MIL-PRF-38535.
4. Package dimensions and symbols are similar to MIL-STD-1835 Requirement 101, Configuration B.
5. Lead position and coplanarity are not measured.
6. ID mark symbol is vendor option.
7. With solder, increase maximum by 0.003.

**Figure 11. 64-pin Flatpack**

## ORDERING INFORMATION

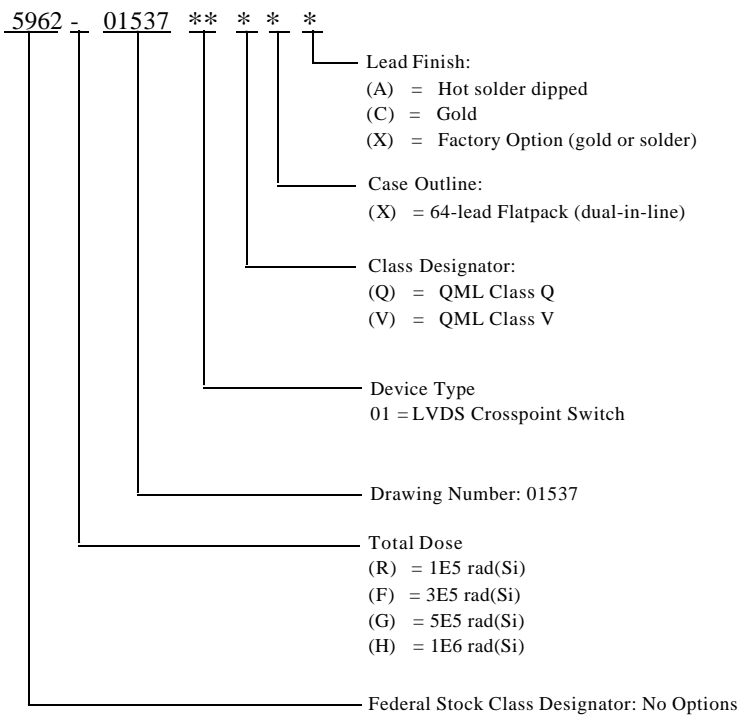
### UT54LVDM228 Crosspoint Switch:



#### Notes:

1. Lead finish (A,C, or X) must be specified.
2. If an "X" is specified when ordering, then the part marking will match the lead finish and will be either "A" (solder) or "C" (gold).
3. Prototype flow per UTMC Manufacturing Flows Document. Tested at 25°C only. Lead finish is GOLD ONLY. Radiation neither tested nor guaranteed.
4. Military Temperature Range flow per UTMC Manufacturing Flows Document. Devices are tested at -55°C, room temp, and 125°C. Radiation neither tested nor guaranteed.

**UT54LVDM228 Crosspoint Switch: SMD**



**Notes:**

1. Lead finish (A, C, or X) must be specified.
2. If an "X" is specified when ordering, part marking will match the lead finish and will be either "A" (solder) or "C" (gold).
3. Total dose radiation must be specified when ordering. QML Q and QML V not available without radiation hardening.

## NOTES