

UT67164 Radiation-Hardened 8K x 8 SRAM -- SEU Hard



FEATURES

- ❑ 55ns maximum address access time, single-event upset less than 1.0E-10 errors/bit day (-55°C to 125+°C)
- ❑ Asynchronous operation for compatibility with industry-standard 8K x 8 SRAM
- ❑ TTL-compatible input and output levels
- ❑ Three-state bidirectional data bus
- ❑ Low operating and standby current
- ❑ Full military operating temperature range, -55°C to 125+°C, screened to specific test methods listed in Table I MIL-STD-883 Method 5004 for Class S or Class B
- ❑ Radiation-hardened process and design; total dose irradiation testing to MIL-STD-883 Method 1019
 - Total-dose: 1.0E6 rads(Si)
 - Dose rate upset: 1.0E9 rads (Si)/sec
 - Dose rate survival: 1.0E12 rads (Si)/sec
 - Single-event upset: <1.0E-10 errors/bit-day
- ❑ Industry standard (JEDEC) 64K SRAM pinout
- ❑ Packaging options:
 - 28-pin 100-mil center DIP (.600 x 1.2)
 - 28-pin 50-mil center flatpack (.700 x .75)

- ❑ 5-volt operation
- ❑ Post-radiation AC/DC performance characteristics guaranteed by MIL-STD-883 Method 1019 testing at 1.0E6 rads(Si)

INTRODUCTION

The UT67164 SRAM is a high performance, asynchronous, radiation-hardened, 8K x 8 random access memory conforming to industry-standard fit, form, and function. The UT67164 SRAM features fully static operation requiring no external clocks or timing strobes. UTMC designed and implemented the UT67164 using an advanced radiation-hardened twin-well CMOS process. Advanced CMOS processing along with a device enable/disable function result in a high performance, power-saving SRAM. The combination of radiation-hardness, fast access time, and low power consumption make UT67164 ideal for high-speed systems designed for operation in radiation environments.

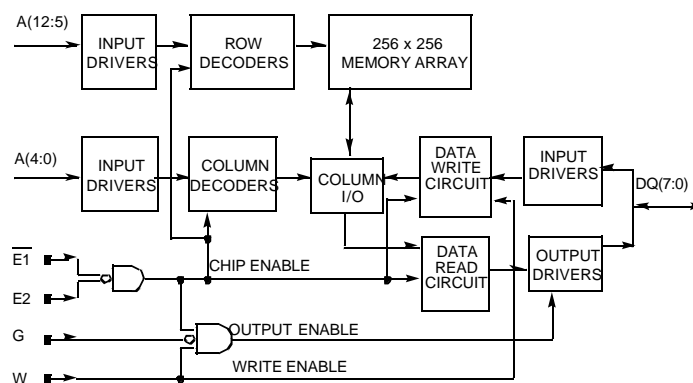

Figure 1. SRAM Block Diagram

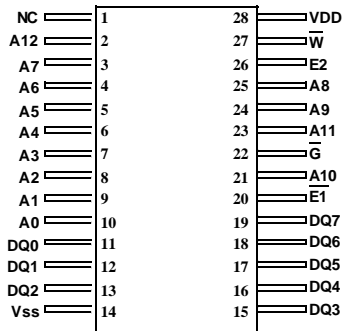

Figure 2. SRAM Pinout

PIN NAMES

A(12:0)	Address	\overline{W}	Write
DQ(7:0)	Data Input/Output	\overline{G}	Output Enable
$\overline{E1}$	Enable 1	V_{DD}	Power
$E2^1$	Enable 2	V_{SS}	Ground

DEVICE OPERATION

The UT67164 has four control inputs called Enable 1 ($\overline{E1}$), Enable 2 (E2), Write Enable (\overline{W}), and Output Enable (\overline{G}); 13 address inputs, A(12:0); and eight bidirectional data lines, DQ(7:0). E1 and E2 are device enable inputs that control device selection, active, and standby modes. Asserting both E1 and E2 enables the device, causes I_{DD} to rise to its active value, and decodes the 13 address inputs to select one of 8,192 words in the memory. \overline{W} controls read and write operations. During a read cycle, \overline{G} must be asserted to enable the outputs.

Table 1. Device Operation Truth Table

\overline{G}	\overline{W}	$\overline{E1}$	E2	I/O Mode	Mode
X ¹	X	X	0	3-state	Standby
X	X	1	X	3-state	Standby
X	0	0	1	Data in	Write
1	1	0	1	3-state	Read ²
0	1	0	1	Data out	Read

Notes:

- 1. "X" is defined as a "don't care" condition.
- 2. Device active; outputs disabled.

READ CYCLE

A combination of \overline{W} greater than V_{IH} (min), $\overline{E1}$ less than V_{IL} (max), and E2 greater than V_{IH} (min) defines a read cycle. Read access time is measured from the latter of device enable, Output Enable, or valid address to valid data output.

Read Cycle 1, the Address Access read in figure 3a, is initiated by a change in address inputs while the chip is enabled with \overline{G} asserted and \overline{W} deasserted. Valid data appears on data outputs DQ(7:0) after the specified t_{AVQV} is satisfied. Outputs remain active throughout the entire cycle. As long as device enable and output enable are active, the address inputs may change at a rate equal to the minimum read cycle time (t_{AVAV}).

Figure 3b shows Read Cycle 2, the Chip Enable-controlled Access. For this cycle, \overline{G} remains asserted, \overline{W} remains deasserted, and the addresses remain stable for the entire cycle. After the specified t_{ETQV} is satisfied, the eight-bit word addressed by A(12:0) is accessed and appears at the data outputs DQ(7:0).

Figure 3c shows Read Cycle 3, the Output Enable-controlled Access. For this cycle, $\overline{E1}$ and E2 are asserted, \overline{W} is deasserted, and the addresses are stable before \overline{G} is enabled. Read access time is t_{GLQV} unless t_{AVQV} or t_{ETQV} have not been satisfied.

WRITE CYCLE

A combination of \overline{W} less than $V_{IL}(\max)$, $\overline{E1}$ less than $V_{IL}(\max)$, and $E2$ greater than $V_{IH}(\min)$ defines a write cycle. The state of \overline{G} is a “don’t care” for a write cycle. The outputs are placed in the high-impedance state when either \overline{G} is greater than $V_{IH}(\min)$, or when \overline{W} is less than $V_{IL}(\max)$.

Write Cycle 1, the Write Enable-controlled Access shown in figure 4a, is defined by a write terminated by \overline{W} going high, with $\overline{E1}$ and $E2$ still active. The write pulse width is defined by t_{WLWH} when the write is initiated by \overline{W} , and by t_{ETWH} when the write is initiated by the latter of $\overline{E1}$ or $E2$. Unless the outputs have been previously placed in the high-impedance state by \overline{G} , the user must wait t_{WLQZ} before applying data to the eight bidirectional pins $DQ(7:0)$ to avoid bus contention.

Write Cycle 2, the Chip Enable-controlled Access shown in figure 4b, is defined by a write terminated by the latter of $\overline{E1}$ or $E2$ going inactive. The write pulse width is defined by t_{WLEF} when the write is initiated by \overline{W} , and by t_{ETEF} when the write is initiated by the latter of $\overline{E1}$ or $E2$ going active. For the \overline{W} initiated write, unless the outputs have been previously placed in the high-impedance state by \overline{G} , the user must wait t_{WLQZ} before applying data to the eight bidirectional pins $DQ(7:0)$ to avoid bus contention.

RADIATION HARDNESS

The UT67164 SRAM incorporates special design and layout features which allow operation in high-level radiation environments.

Table 2. Radiation Hardness Design Specifications¹

Total Dose	1.0E6	rads(Si)
Dose Rate Upset	1.0E9	rads(Si)/s 20ns pulse
Dose Rate Survival	1.0E12	rads(Si)/s 20ns pulse
Single-Event Upset	1.0E-10	errors/bit day ²
Neutron Fluences	3.0E14	n/cm ²

Notes:

1. The SRAM will not latchup during radiation exposure under recommended operating conditions.
2. 90% Adam’s worst case spectrum (-55°C to 125+°C).

Table 3. SEU versus Temperature

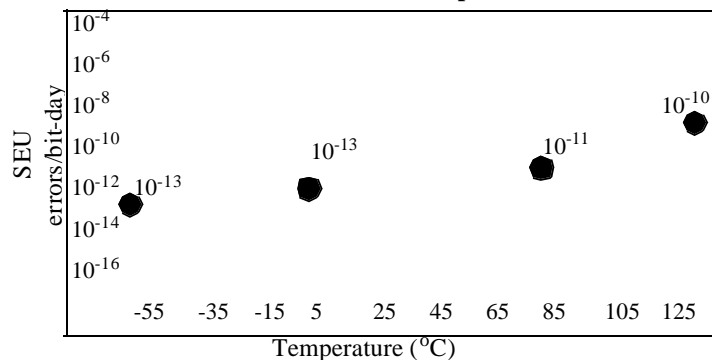

ABSOLUTE MAXIMUM RATINGS¹

(Referenced to V_{SS})

SYMBOL	PARAMETER	LIMITS
V_{DD}	DC supply voltage	-0.5 to 7.0V
V_{IO}	Voltage on any pin	-0.5 to $V_{DD} + 0.5$
T_{STG}	Storage temperature	-65 to +150°C
P_D	Maximum power dissipation	1.0W
T_J	Maximum junction temperature	+150°C
Θ_{JC}	Thermal resistance, junction-to-case ²	10°C/W
I_{LU}	Latchup immunity	+/-150mA
I_I	DC input current	+/- 10 mA

Notes:

1. Stresses outside the listed absolute maximum ratings may cause permanent damage to the device. This is a stress rating only, and functional operation of the device at these or any other conditions beyond limits indicated in the operational sections of this specification is not recommended. Exposure to absolute maximum rating conditions for extended periods may affect device reliability.
2. Test per MIL-STD-883, Method 1012.

RECOMMENDED OPERATING CONDITIONS

SYMBOL	PARAMETER	LIMITS	UNITS
V_{DD}	Positive supply voltage	4.5 to 5.5V	V
T_C	Case temperature range	-55 to +125°C	°C
V_{IN}	DC input voltage	0V to V_{DD}	V

DC ELECTRICAL CHARACTERISTICS (Pre/Post-Radiation)*(V_{DD} = 5.0V±10%; -55°C <T_c < +125°C)

SYMBOL	PARAMETER	CONDITION	MIN	MAX	UNIT
V _{IH}	High-level input voltage		2.2		V
V _{IL}	Low-level input voltage			0.8	V
V _{OL}	Low-level output voltage	I _{OL} = +/- 4.0mA, V _{DD} = 4.5V		0.4	V
V _{OH}	High-level output voltage	I _{OH} = +/-4mA, V _{DD} = 4.5V	2.4		V
C _{IN} ¹	Input capacitance	f = 1MHz @ 0V, V _{DD} = 4.5V		15	pF
C _{IO} ¹	Bidirectional I/O capacitance	f = 1MHz @ 0V, V _{DD} = 4.5V		20	pF
I _{IN}	Input leakage current	V _{IN} = V _{DD} and V _{SS}	-10	+10	μA
I _{OZ}	Three-state output leakage current	V _O = V _{DD} and V _{SS} V _{DD} = 5.5V G = 5.5V	-10	+10	μA
I _{OS} ^{2, 3}	Short-circuit output current	V _{DD} = 5.5V, V _O = V _{DD} V _{DD} = 5.5V, V _O = 0V	-90	+90	mA mA
I _{DD} (OP)	Supply current operating @1MHz	CMOS inputs (I _{OUT} = 0) V _{DD} = 5.5V		40	mA
I _{DD} (SB) pre-rad	Supply current standby	CMOS inputs (I _{OUT} = 0) E _I = V _{DD} - 0.5, V _{DD} = 5.5V		200	μA
I _{DD} (SB) post-rad	Supply current standby @ f = 0Hz	CMOS inputs (I _{OUT} = 0) CS1 = negated V _{DD} = 5.5V CS2 = negated		3	mA

Notes:

* Post-radiation performance guaranteed at 25°C per MIL-STD-883 Method 1019 at 1.0E6 rads(Si).

1. Measured only for initial qualification and after process or design changes that could affect input/output capacitance.
2. Supplied as a design limit but not guaranteed or tested.
3. Not more than one output may be shorted at a time for maximum duration of one second.

AC CHARACTERISTICS READ CYCLE (Post-Radiation)*

($V_{DD} = 5.0V \pm 10\%$; $-55^{\circ}C < T_C < +125^{\circ}C$)

SYMBOL	PARAMETER	67164-85		67164-70		67164-55		UNIT
		MIN	MAX	MIN	MAX	MIN	MAX	
t_{AVAV}	Read cycle time	85		70		55		ns
t_{AVQV}	Read access time		85		70		55	ns
t_{AXQX}	Output hold time	5		5		5		ns
t_{GLQX}	\overline{G} -controlled output enable time	0		0		0		ns
t_{GLQV}	\overline{G} -controlled output enable time (Read Cycle 3)		30		15		15	ns
t_{GHQZ}	\overline{G} -controlled output three-state time		15		15		15	ns
t_{ETQX}^1	E-controlled output enable time	0		0		0		ns
t_{ETQV}^1	E-controlled access time		85		70		55	ns
t_{EFQZ}^2	E-controlled output three-state time ³		25		20		20	ns

Notes: * Post-radiation performance guaranteed at 25°C per MIL-STD-883 Method 1019 at 1.0E6 rads(Si).

1. The ET (enable true) notation refers to the rising edge of E2 or the falling edge of $\overline{E1}$, whichever comes last. SEU immunity does not affect the read parameters.
2. The EF (enable false) notation refers to the falling edge of E2 or the rising edge of E1, whichever comes first. SEU immunity does not affect the read parameters.
3. Three-state is defined as a 500mV change from steady-state output voltage.

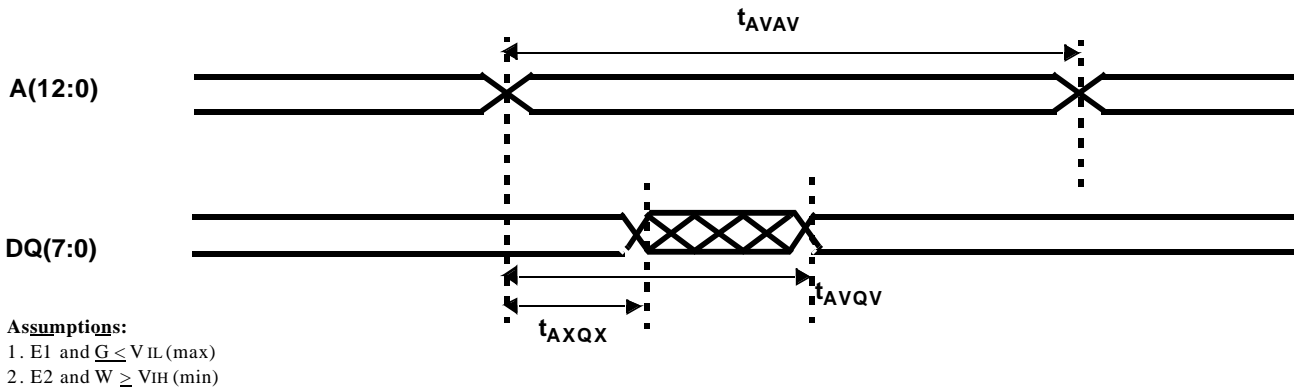

Figure 3a. SRAM Read Cycle 1: Address Access

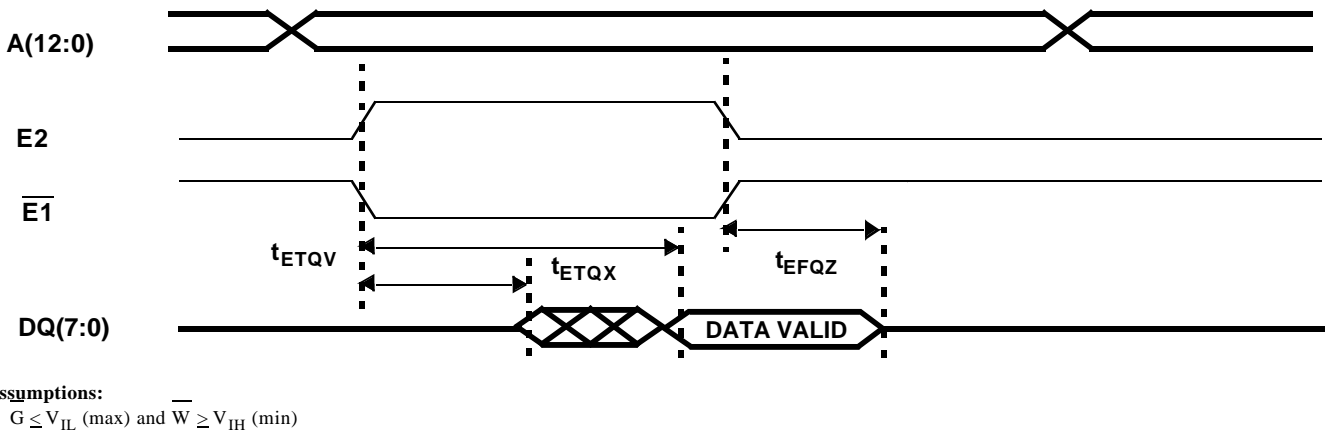

Figure 3b. SRAM Read Cycle 2: Chip Enable Access

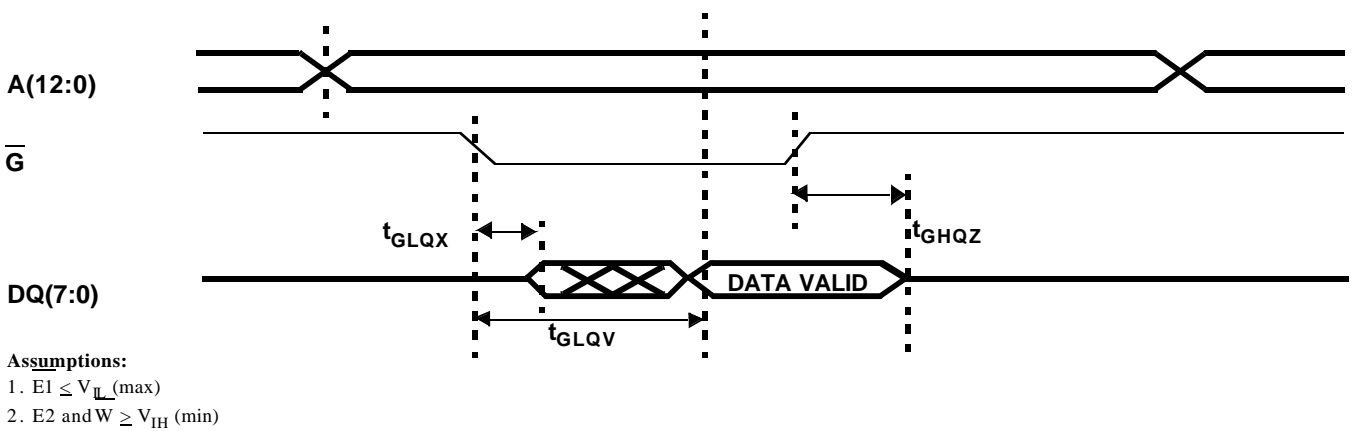

Figure 3c. SRAM Read Cycle 3: Output Enable Access

AC CHARACTERISTICS WRITE CYCLE (Post-Radiation)*

($V_{DD} = 5.0V \pm 10\%$; $-55^{\circ}C < T_C < +125^{\circ}C$)

SYMBOL	PARAMETER	67164-85		67164-70		67164-55		UNIT
		MIN	MAX	MIN	MAX	MIN	MAX	
t_{AVAV}	Write cycle time	85		70		55		ns
t_{ETWH}	Device enable to end of write	65		60		50		ns
t_{AVET}	Address setup time for write ($\overline{E1}$ or E2 - controlled)	0		0		0		ns
t_{AVWL}	Address setup time for write (\overline{W} - controlled)	0		0		0		ns
t_{WLWH}	Write pulse width	50		35		35		ns
t_{WHAX}	Address hold time for write (\overline{W} - controlled)	0		0		0		ns
t_{EFAX}	Address hold time for device enable (E1 or E2 - controlled)	0		0		0		ns
t_{WLQZ}	\overline{W} - controlled three-state time		15		15		15	ns
t_{WHQX}	\overline{W} - controlled output enable time	0		0		0		ns
t_{ETEF}	Device enable pulse width (E1 or E2 - controlled)	65		60		55		ns
t_{DVWH}	Data setup time	50		35		35		ns
t_{WHDX}	Data hold time	0		0		0		ns
t_{WLEF}	Device enable controlled write pulse width	65		60		50		ns
t_{DVEF}	Data setup time	50		35		35		ns
t_{EFDX}	Data hold time	0		0		0		ns

Notes:

* Post-radiation performance guaranteed at 25°C per MIL-STD-883 Method 1019at 1.0E6 rads(Si).

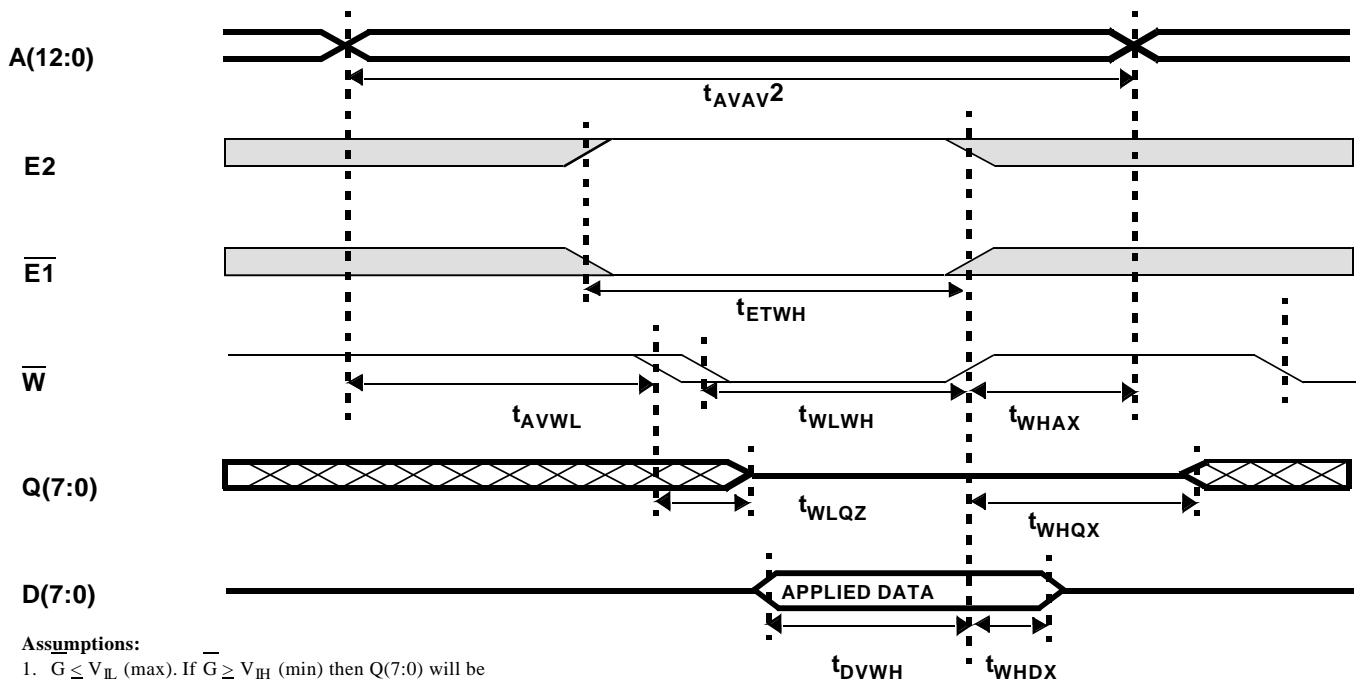
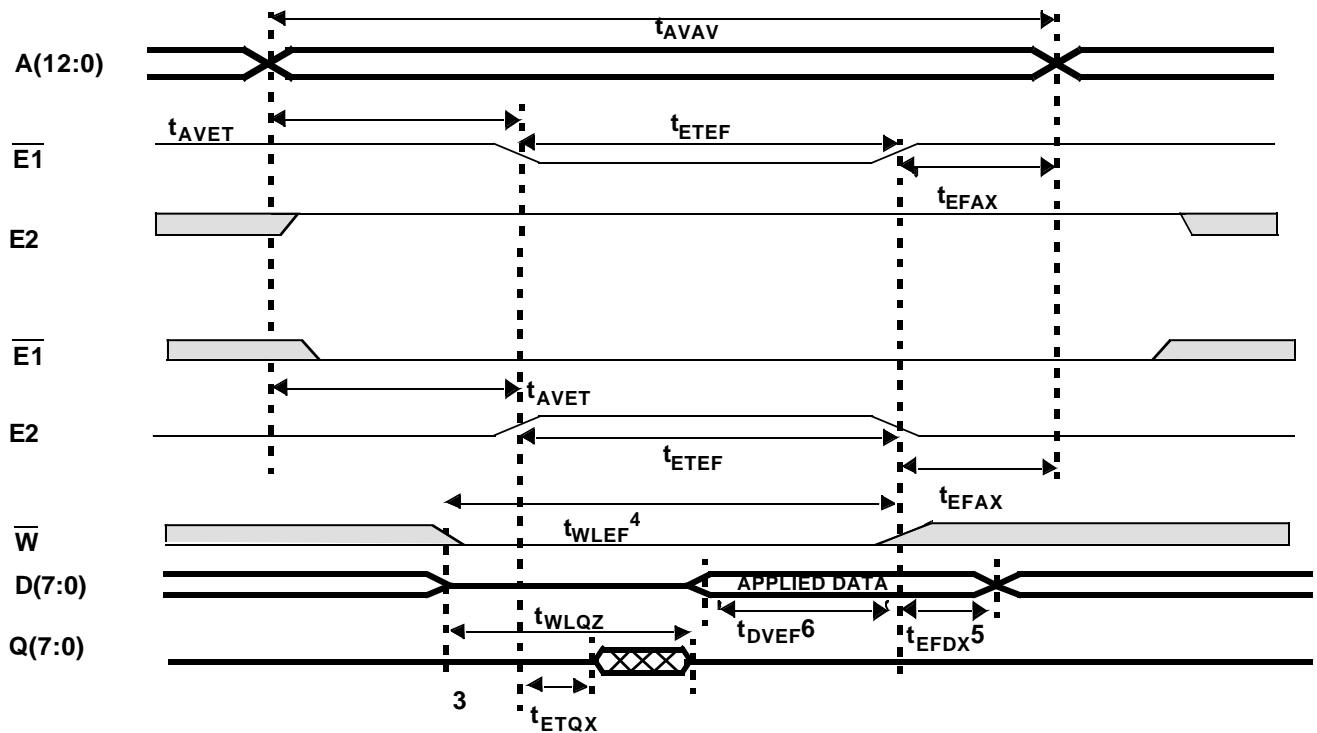

Figure 4a. SRAM Write Cycle 1: \overline{W} - Controlled Access



Assumptions & Notes:

1. $G \leq V_{IL}(\max)$. If $G \geq V_{IH}(\min)$ then $Q(7:0)$ will be in three-state for the entire cycle.
2. Either $\overline{E1}/E2$ scenario above can occur.
3. If $\overline{E1}$ or $E2$ is asserted simultaneously with or after the \overline{W} low transition, the outputs will remain in a high-impedance state.
4. $t_{WLEF} = t_{ETWH}$.
5. $t_{EFDX} = t_{WHDX}$.
6. $t_{DVEF} = t_{DVWH}$.

Figure 4b. SRAM Write Cycle 2: Enable - Controlled Access

DATA RETENTION CHARACTERISTICS (Post-Radiation)

($T_C = 25^\circ\text{C}$)

SYMBOL	PARAMETER	MINIMUM	MAXIMUM		UNIT
			$V_{DD} @ 2.0\text{V}$	$V_{DD} @ 3.0\text{V}$	
V_{DR}	V_{DD} for data retention	2.5	--		V
I_{DDDR}^1	Data retention current	--	75	90	μA
t_{EFR}^1	Chip deselect to data retention time	0			ns
t_R^1	Operation recovery time	t_{AVAV}			ns

Notes:

* Post-radiation performance guaranteed at 25°C per MIL-STD-883 Method 1019 at $1.0\text{E}6$ rads(Si).

1. $V_{LC} = 0.2\text{V}$, $V_{HC} = V_{DD} - 0.2\text{V}$, $E1 \geq V_{HC}$, $E2 > V_{HC}$

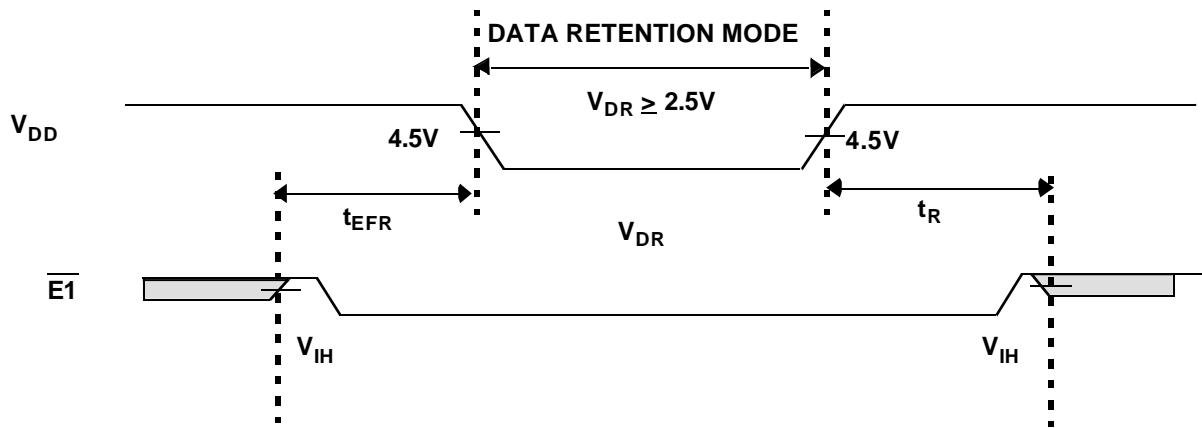
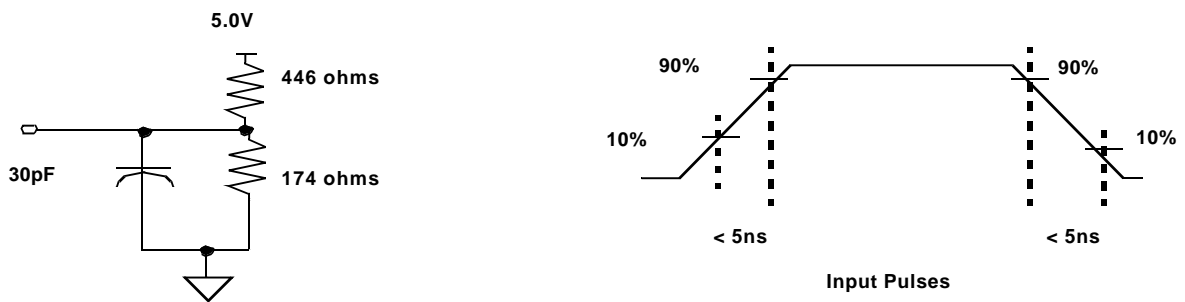

Figure 5. Low V_{DD} Data Retention Waveform



Notes:

1. 30pF including scope probe and test socket.
2. Measurement of data output occurs at the low to high or high to low transition mid-point

Figure 6. AC Test Loads and Input Waveforms

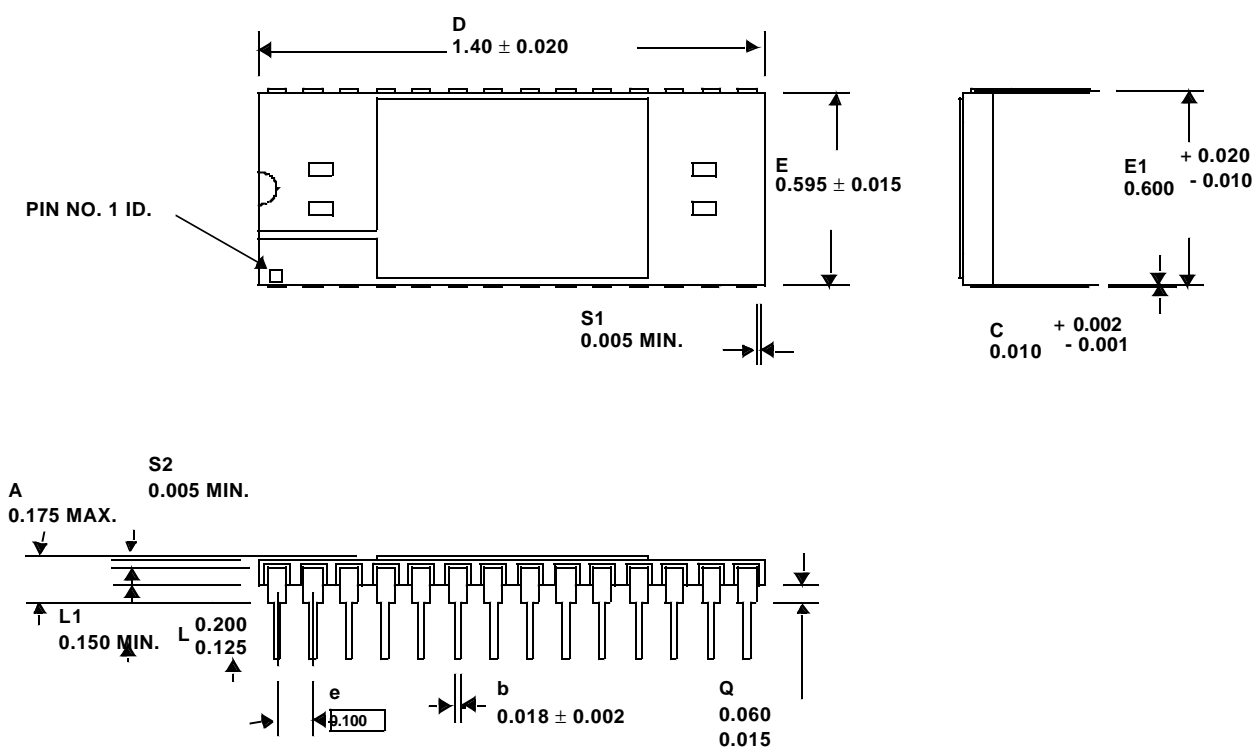

Notes:

1. Seal ring to be electrically isolated.
2. All exposed metalized areas to be plated per MIL-PRF-38535.
3. Ceramic to be opaque.
4. Dimension letters refer to MIL-STD-1835.

Figure 7. 28-pin Ceramic DIP Package

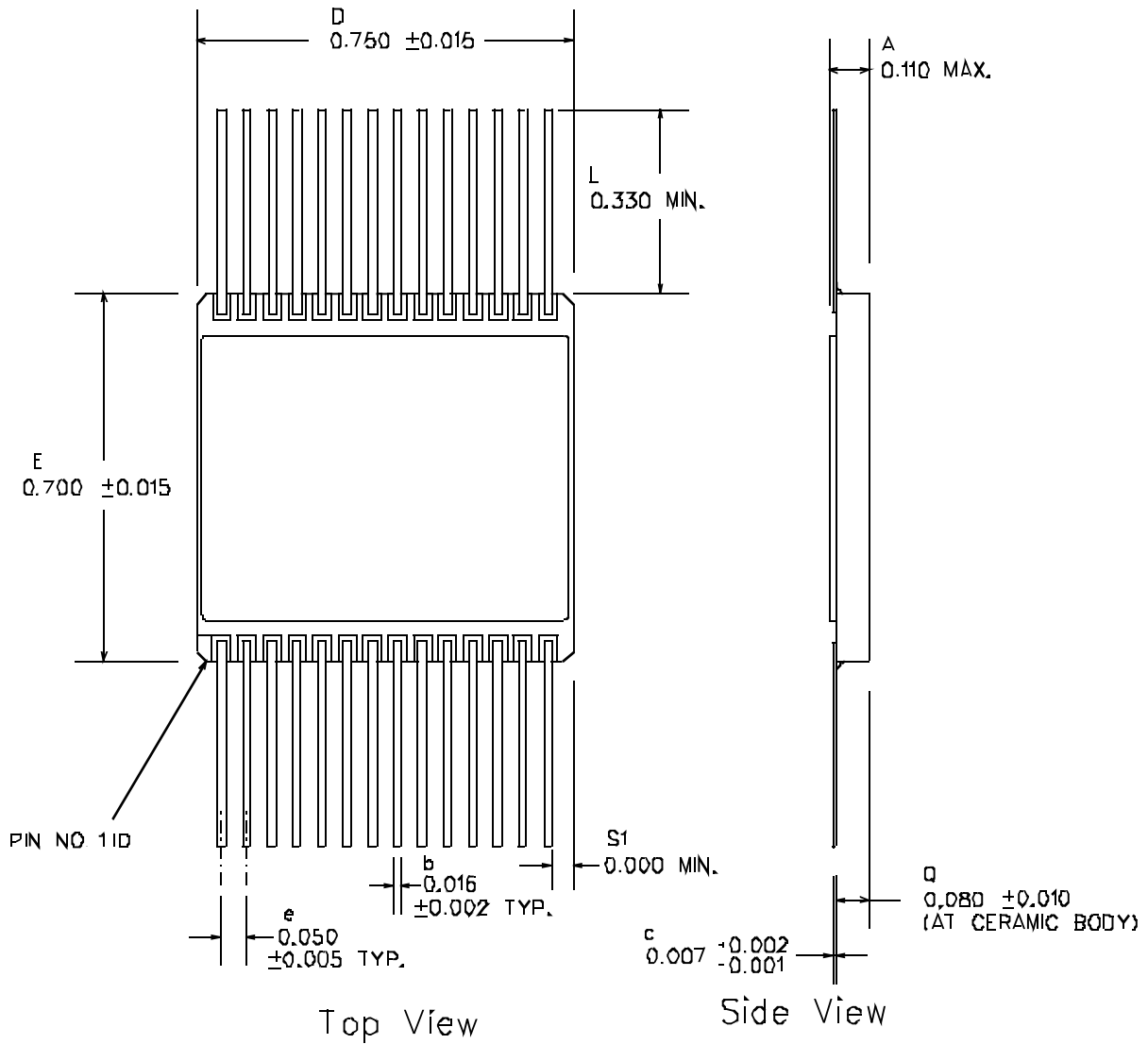

Notes:

1. Lid is electrically isolated.
2. All exposed metalized areas are plated per MIL-PRF-38535.
3. Ceramic is opaque.
4. Dimension letters refer to MIL-STD-1835

Figure 8. 28-Lead 50-mil Center Flatpack (0.700 x 0.75)

ORDERING INFORMATION

64K SRAM:

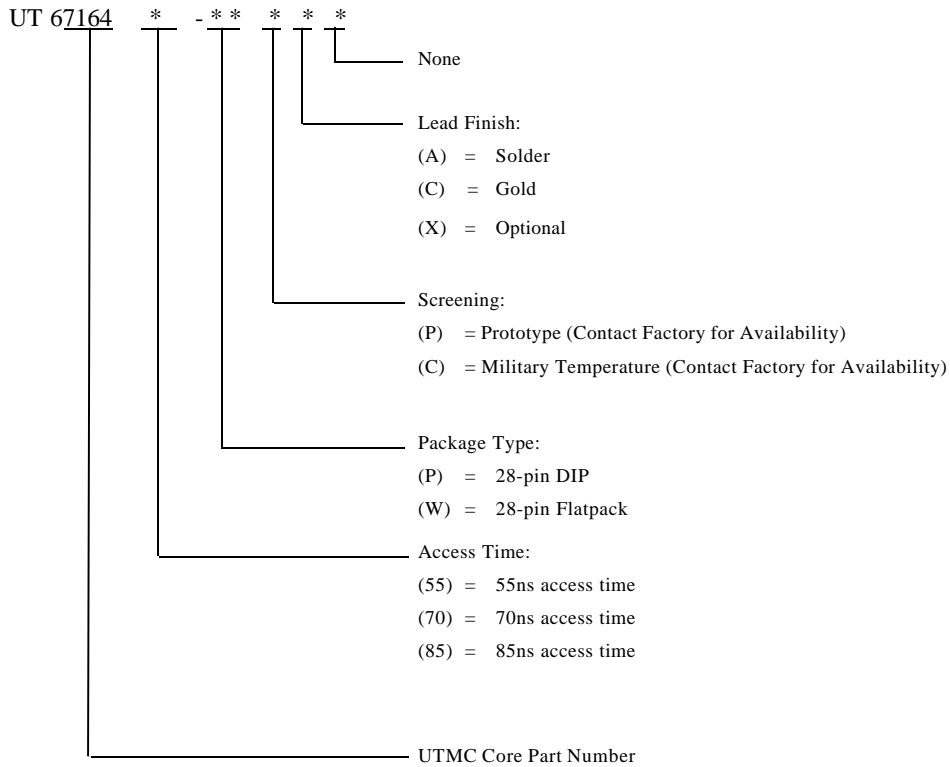

Notes:

1. Lead finish (A,C, or X) must be specified.
2. If an "X" is specified when ordering, then the part marking will match the lead finish and will be either "A" (solder) or "C" (gold).
3. 85 ns not available for prototype flow devices.
4. Mil Temp range flow per UTMC's manufacturing flows document. Devices are tested at -55C, room temp, and 125C. Radiation neither tested nor guaranteed.
5. Prototypes are produced to UTMC's prototype flow, and tested at 25C only. Lead finish is at UTMC's option. Radiation is neither tested nor guaranteed.

64K SRAM: SMD

5962

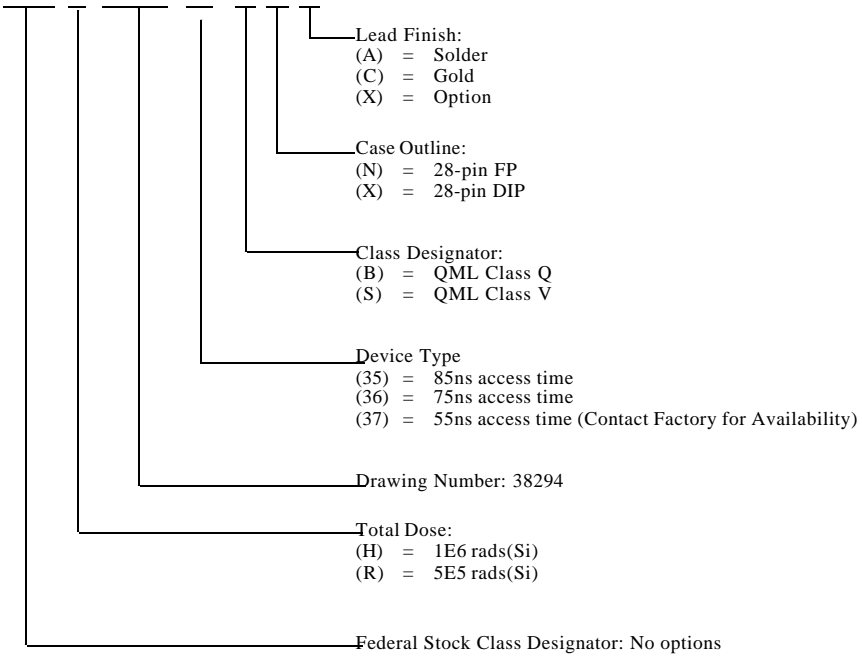

Notes:

1. Lead finish (A,C, or X) must be specified.
2. If an "X" is specified when ordering then the part marking is at the factory's option and will match the lead finish "A" (solder) or "C" (gold).