

FEATURES

- Fast access time : 8/12/15 ns (max.)
- Low operating power consumption : 100 mA (typical)
- Single 5V power supply
- All inputs and outputs TTL compatible
- Fully static operation
- Three state outputs
- Package : 32-pin 300 mil SOJ
32-pin 8x20mm TSOP-I

FUNCTIONAL BLOCK DIAGRAM

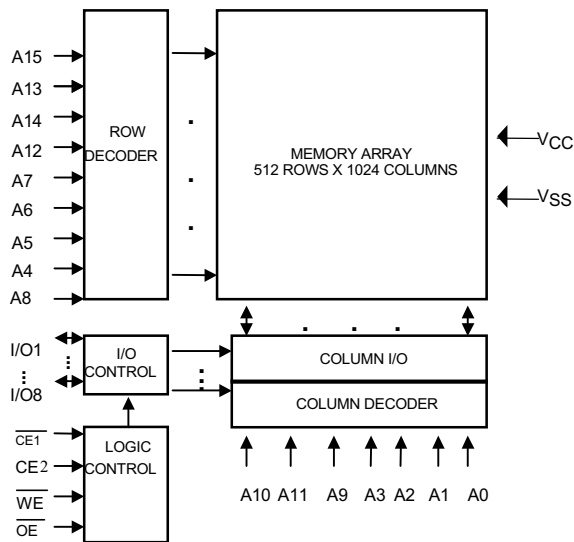

PIN DESCRIPTION

SYMBOL	DESCRIPTION
A0 - A15	Address Inputs
I/O1 - I/O8	Data Inputs/Outputs
CE1	Chip Enable 1 input
CE2	Chip Enable 2 input
WE	Write Enable Input
OE	Output Enable Input
V _{CC}	Power Supply
V _{SS}	Ground
NC	No Connection

GENERAL DESCRIPTION

The UT61512 is a 524,288-bit high-speed CMOS static random access memory organized as 655,036 words by 8 bits. It is fabricated using high performance, high reliability CMOS technology.

The UT61512 is designed for high-speed system applications. It is particularly suited for use in high-density high-speed system applications.

The UT61512 operates from a single 5V power supply and all inputs and outputs are fully TTL compatible.

PIN CONFIGURATION

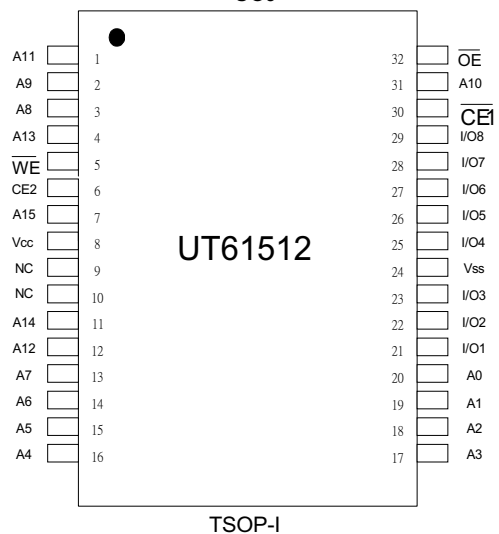
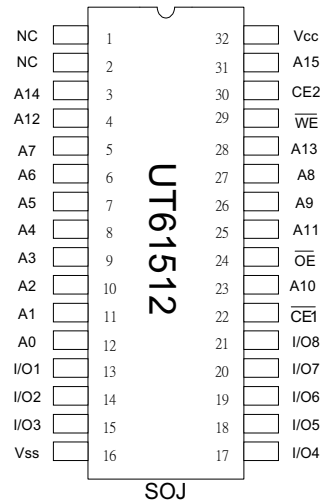

**ABSOLUTE MAXIMUM RATINGS***

PARAMETER	SYMBOL	RATING	UNIT
Terminal Voltage with Respect to V _{SS}	V _{TERM}	-0.5 to +6.5	V
Operating Temperature	T _A	0 to +70	°C
Storage Temperature	T _{STG}	-65 to +150	°C
Power Dissipation	P _D	1	W
DC Output Current	I _{OUT}	50	mA
Soldering Temperature (under 10 sec)	T _{solder}	260	°C

*Stress greater than those listed under "Absolute Maximum Ratings" may cause permanent damage to the device. This is a stress rating only and functional operation of the device or any other conditions above those indicated in the operational sections of this specification is not implied. Exposure to the absolute maximum rating conditions for extended period may affect device reliability.

TRUTH TABLE

MODE	$\overline{CE1}$	CE2	\overline{OE}	\overline{WE}	I/O OPERATION	SUPPLY CURRENT
Standby	H	X	X	X	High - Z	I _{SB} , I _{SB1}
Standby	X	L	X	X	High - Z	I _{SB} , I _{SB1}
Output Disable	L	H	H	H	High - Z	I _{CC}
Read	L	H	L	H	D _{OUT}	I _{CC}
Write	L	H	X	L	D _{IN}	I _{CC}

Note: H = V_{IH}, L = V_{IL}, X = Don't care.

DC ELECTRICAL CHARACTERISTICS (V_{CC} = 5.0V ± 10%, T_A = 0°C to 70°C)

PARAMETER	SYMBOL	TEST CONDITION	MIN.	MAX.	UNIT	
Input High Voltage	V _{IH}		2.2	V _{CC} +0.5	V	
Input Low Voltage	V _{IL}		-0.5	0.8	V	
Input Leakage Current	I _{LI}	V _{SS} ≤ V _{IN} ≤ V _{CC}	-1	1	μA	
Output Leakage Current	I _{LO}	V _{SS} ≤ V _{I/O} ≤ V _{CC} $\overline{CE1} = V_{IH}$ or CE2 = V _{IL} or $\overline{OE} = V_{IH}$ or $\overline{WE} = V_{IL}$	-1	1	μA	
Output High Voltage	V _{OH}	I _{OH} = -4mA	2.4	-	V	
Output Low Voltage	V _{OL}	I _{OL} = 8mA	-	0.4	V	
Operating Power	I _{CC}	$\overline{CE1} = V_{IL}$, CE2 = V _{IH} I _{I/O} = 0mA, Cycle=Min.	-8	-	190	mA
Supply Current			-12	-	160	mA
			-15	-	140	mA
Standby Power	I _{SB}	$\overline{CE1} = V_{IH}$ or CE2 = V _{IL}	-	30	mA	
Supply Current	I _{SB1}	$\overline{CE1} \geq V_{CC}-0.2V$ or CE2 ≤ 0.2V	-	5	mA	

**CAPACITANCE** ($T_A=25^{\circ}\text{C}$, $f=1.0\text{MHz}$)

PARAMETER	SYMBOL	MIN.	MAX.	UNIT
Input Capacitance	C_{IN}	-	8	pF
Input/Output Capacitance	$C_{I/O}$	-	10	pF

Note : These parameters are guaranteed by device characterization, but not production tested.

AC TEST CONDITIONS

Input Pulse Levels	0V to 3.0V
Input Rise and Fall Times	3ns
Input and Output Timing Reference Levels	1.5V
Output Load	$C_L=30\text{pF}$, $I_{OH}/I_{OL}=-4\text{mA}/8\text{mA}$

AC ELECTRICAL CHARACTERISTICS ($V_{CC} = 5V \pm 10\%$, $T_A = 0^{\circ}\text{C}$ to 70°C)**(1) READ CYCLE**

PARAMETER	SYMBOL	UT61512-8		UT61512-12		UT61512-15		UNIT
		MIN.	MAX.	MIN.	MAX.	MIN.	MAX.	
Read Cycle Time	t_{RC}	8	-	12	-	15	-	ns
Address Access Time	t_{AA}	-	8	-	12	-	15	ns
Chip Enable Access Time	t_{ACE}	-	8	-	12	-	15	ns
Output Enable Access Time	t_{OE}	-	4	-	6	-	7	ns
Chip Enable to Output in Low Z	t_{CLZ}^*	2	-	3	-	4	-	ns
Output Enable to Output in Low Z	t_{OLZ}^*	0	-	0	-	0	-	ns
Chip Disable to Output in High Z	t_{CHZ}^*	-	4	-	6	-	7	ns
Output Disable to Output in High Z	t_{OHZ}^*	-	4	-	6	-	7	ns
Output Hold from Address Change	t_{OH}	3	-	3	-	3	-	ns

(2) WRITE CYCLE

PARAMETER	SYMBOL	UT61512-8		UT61512-12		UT61512-15		UNIT
		MIN.	MAX.	MIN.	MAX.	MIN.	MAX.	
Write Cycle Time	t_{WC}	8	-	12	-	15	-	ns
Address Valid to End of Write	t_{AW}	6.5	-	10	-	12	-	ns
Chip Enable to End of Write	t_{CW}	6.5	-	10	-	12	-	ns
Address Set-up Time	t_{AS}	0	-	0	-	0	-	ns
Write Pulse Width	t_{WP}	6.5	-	9	-	10	-	ns
Write Recovery Time	t_{WR}	0	-	0	-	0	-	ns
Data to Write Time Overlap	t_{DW}	4	-	6	-	7	-	ns
Data Hold from End of Write Time	t_{DH}	0	-	0	-	0	-	ns
Output Active from End of Write	t_{OW}^*	1.5	-	3	-	4	-	ns
Write to Output in High Z	t_{WHZ}^*	-	4	-	6	-	7	ns

*These parameters are guaranteed by device characterization, but not production tested.



TIMING WAVEFORMS

READ CYCLE 1 (Address Controlled) (1,2,4)

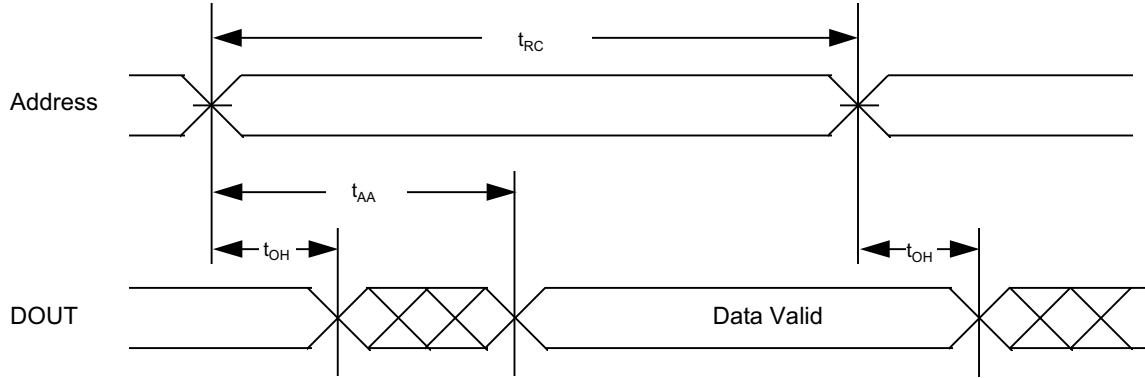

READ CYCLE 2 (\overline{CE} and \overline{OE} Controlled) (1,3,5,6)

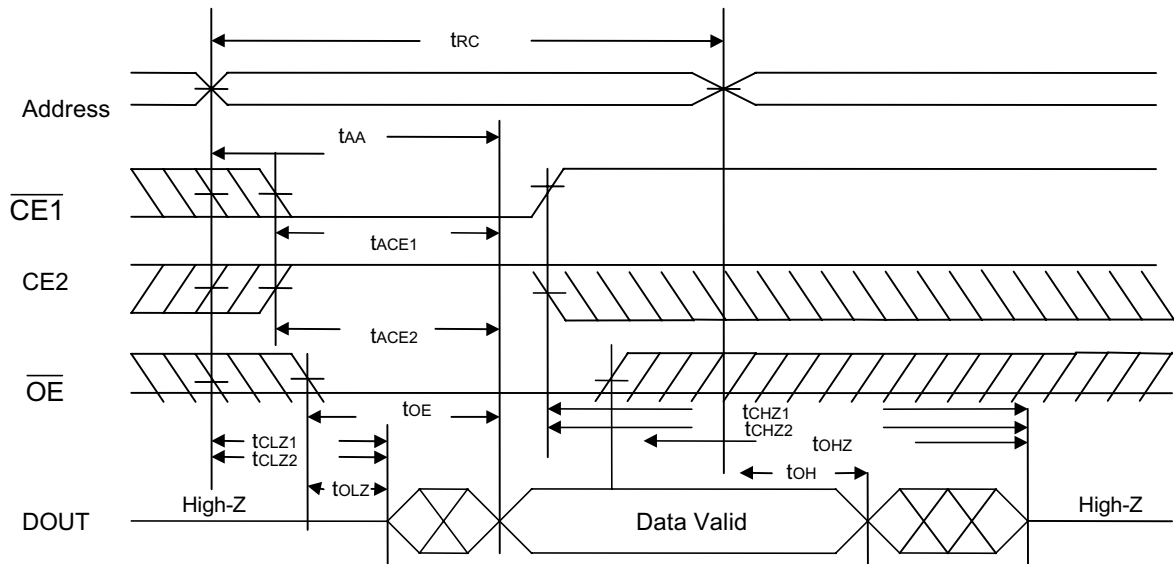

Notes :

1. \overline{WE} is HIGH for read cycle.
2. Device is continuously selected $\overline{CE} = V_{IL}$.
3. Address must be valid prior to or coincident with \overline{CE} transition; otherwise t_{AA} is the limiting parameter.
4. \overline{OE} is LOW.
5. t_{CLZ} , t_{OLZ} , t_{CHZ} and t_{OHZ} are specified with $C_L = 5pF$. Transition is measured $\pm 500mV$ from steady state.
6. At any given temperature and voltage condition, t_{CHZ} is less than t_{CLZ} , t_{OHZ} is less than t_{OLZ} .



WRITE CYCLE 1 (\overline{WE} Controlled) (1,2,3,5)

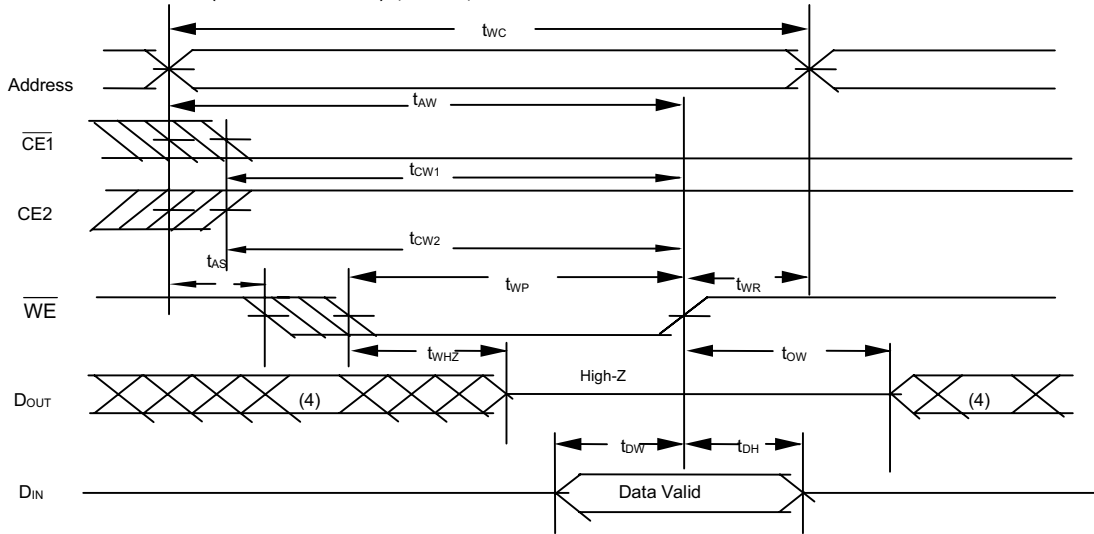

WRITE CYCLE 2 (\overline{CE} Controlled) (1,2,5)

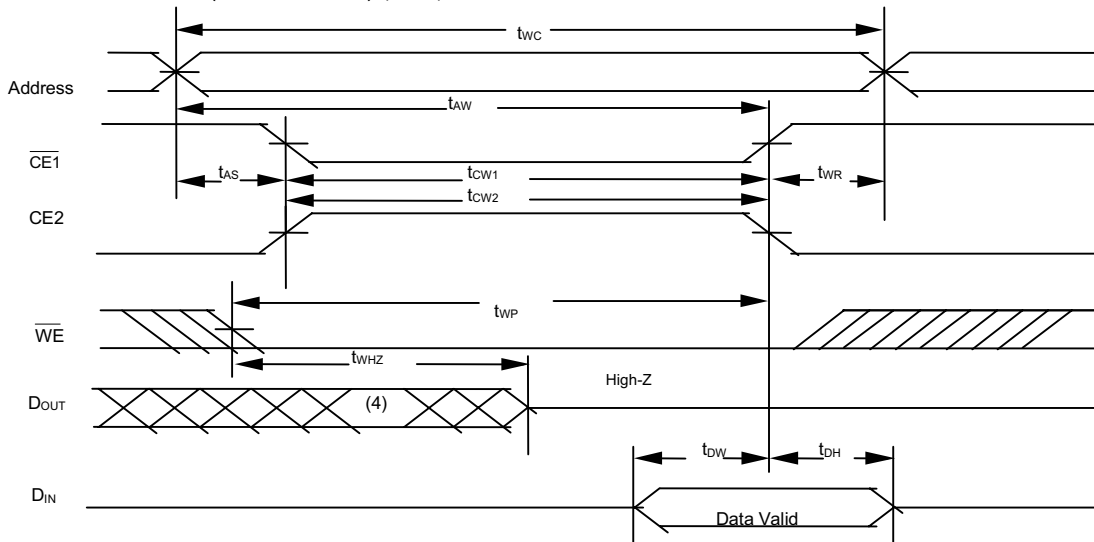

Notes :

1. \overline{WE} or \overline{CE} must be HIGH during all address transitions.
2. A write occurs during the overlap of a low \overline{CE} and a low \overline{WE} .
3. During a \overline{WE} controlled with write cycle with \overline{OE} LOW, t_{WP} must be greater than $t_{WHZ} + t_{DW}$ to allow the drivers to turn off and data to be placed on the bus.
4. During this period, I/O pins are in the output state, and input signals must not be applied.
5. If the \overline{CE} LOW transition occurs simultaneously with or after \overline{WE} LOW transition, the outputs remain in a high impedance state.
6. t_{OW} and t_{WHZ} are specified with $C_L = 5pF$. Transition is measured $\pm 500mV$ from steady state.



PACKAGE OUTLINE DIMENSION

32 pin 300 mil SOJ Package Outline Dimension

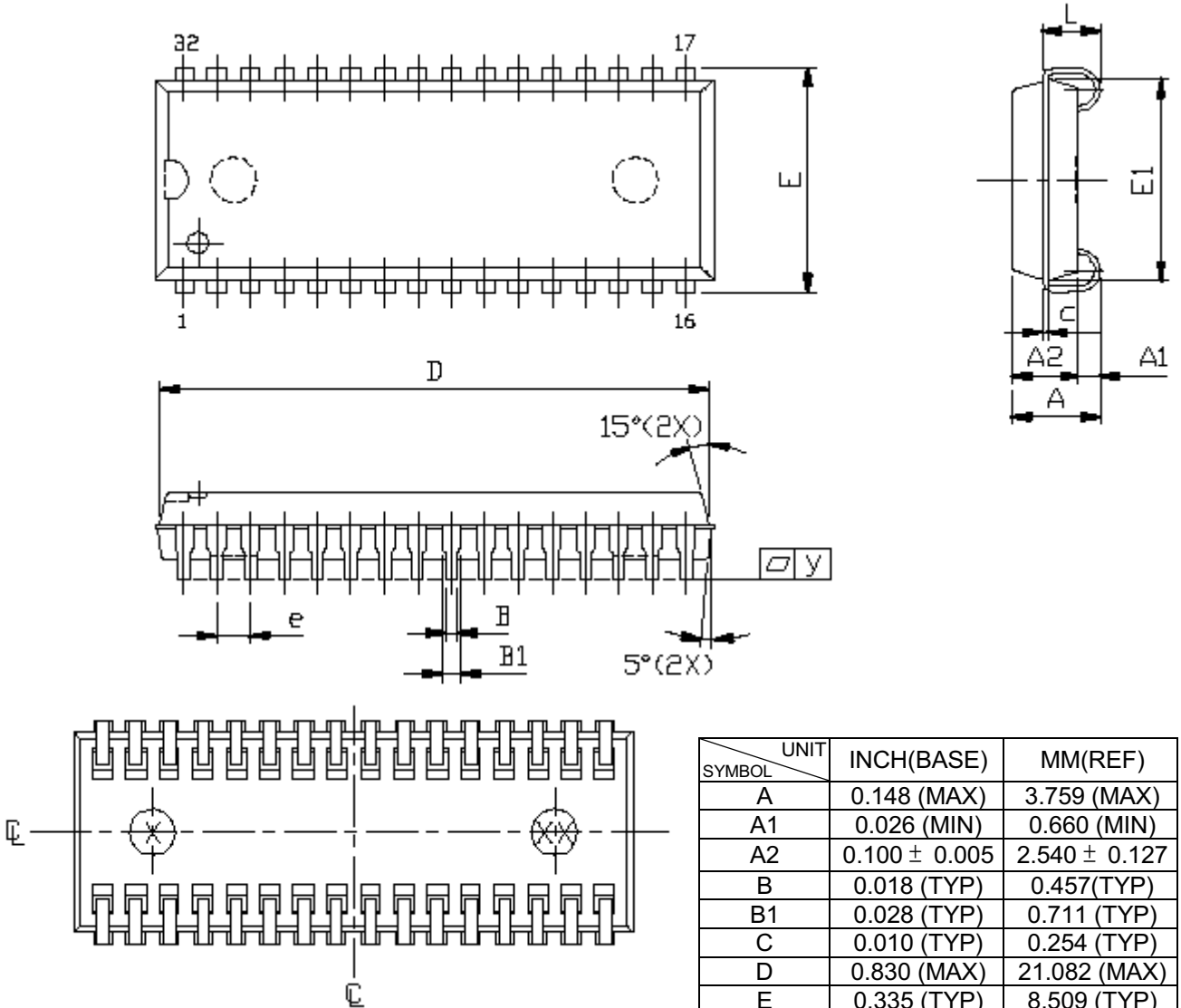

SYMBOL	UNIT	INCH(BASE)	MM(REF)
A		0.148 (MAX)	3.759 (MAX)
A1		0.026 (MIN)	0.660 (MIN)
A2		0.100 ± 0.005	2.540 ± 0.127
B		0.018 (TYP)	0.457(TYP)
B1		0.028 (TYP)	0.711 (TYP)
C		0.010 (TYP)	0.254 (TYP)
D		0.830 (MAX)	21.082 (MAX)
E		0.335 (TYP)	8.509 (TYP)
E1		0.300 ± 0.005	7.620 ± 0.127
e		0.050 (TYP)	1.270 (TYP)
L		0.086 ± 0.010	2.184 ± 0.254
y		0.003 (MAX)	0.076 (MAX)





32PIN TSOP-I Package Outline Dimension

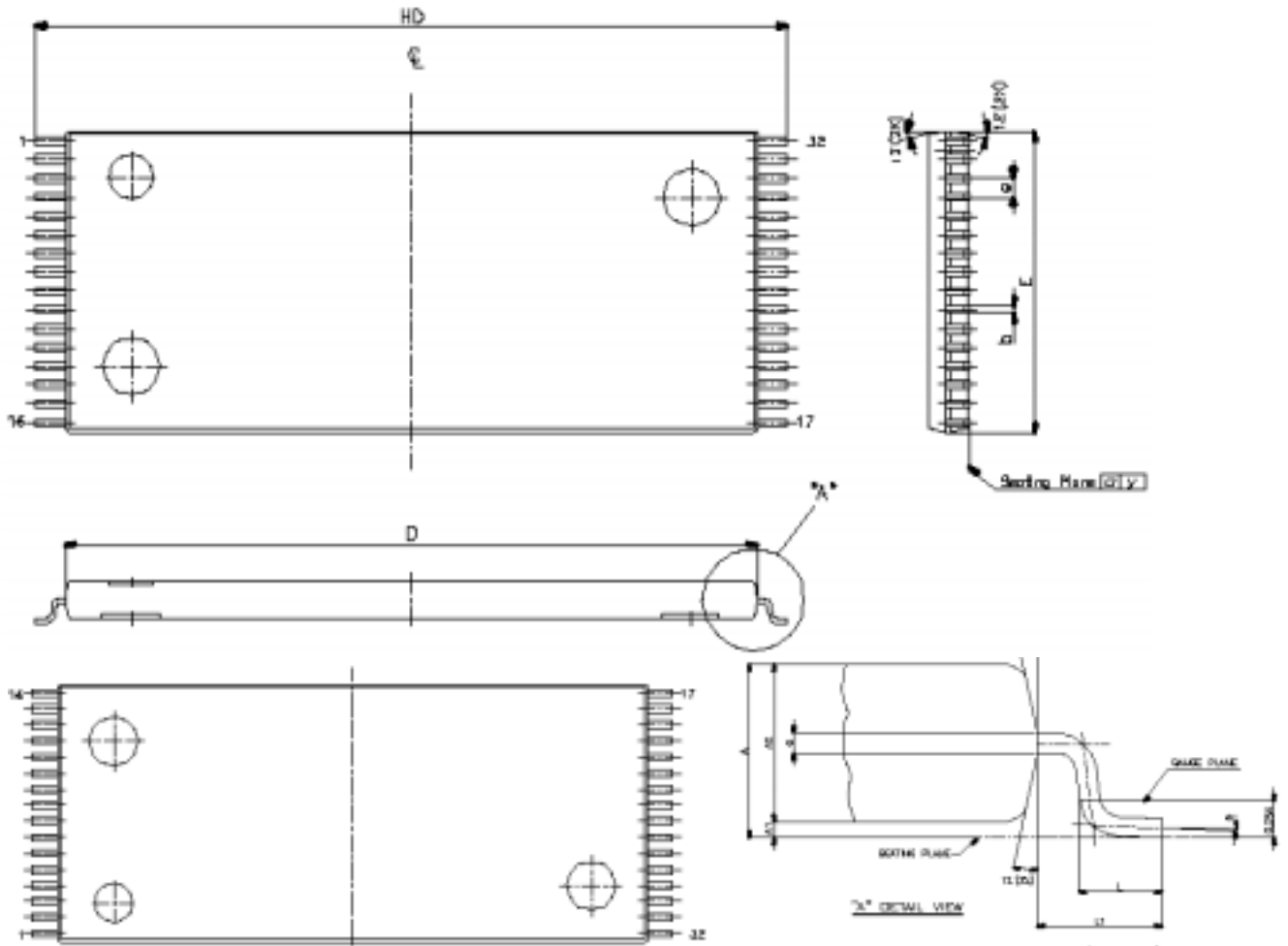

NOTE: 1. L/F MT'L: ALLOY

SYMBOL	UNIT	INCH(BASE)	MM(REF)
A		0.047 (MAX)	1.20 (MAX)
A1		0.004 ± 0.002	0.10 ± 0.05
A2		0.039 ± 0.002	1.00 ± 0.05
b		0.008 + 0.002 - 0.001	0.20 + 0.05 - 0.03
c		0.005 (TYP)	0.127 (TYP)
D		0.724 ± 0.004	18.40 ± 0.10
E		0.315 ± 0.004	8.00 ± 0.10
e		0.020 (TYP)	0.50 (TYP)
HD		0.787 ± 0.008	20.00 ± 0.20
L		0.0197 ± 0.004	0.50 ± 0.10
L1		0.0315 ± 0.004	0.08 ± 0.10
y		0.003 (MAX)	0.076 (MAX)
∅		0°~5°	0°~5°



ORDERING INFORMATION

PART NO.	ACCESS TIME (ns)	PACKAGE
UT61512JC-8	8	32PIN SOJ
UT61512JC-12	12	32PIN SOJ
UT61512JC-15	15	32PIN SOJ
UT61512LC-8	8	32PIN TSOP-I
UT61512LC-12	12	32PIN TSOP-I
UT61512LC-15	15	32PIN TSOP-1



REVISION HISTORY

REVISION	DESCRIPTION	DATE
REV. 1.0	Original.	AUG. 24,1999
REV 1.1	Revise "WRITE CYCLE"	OCT. 18,1999
REV. 1.2	1. Add 32 pin TSOP-I.related information UT61512LC-8, UT61512LC-12 UT61512LC-15 2. The symbols CE1#,OE# and WE# are revised as $\overline{CE1}$, \overline{OE} and \overline{WE}	MAY. 25,2001



UTRON

Rev 1.2

UT61512

64K X 8 BIT HIGH SPEED CMOS RAM

THIS PAGE IS LEFT BLANK INTENTIONALLY.