



FEATURES

- Access time:55ns(max) for Vcc=3.0V~3.6V
70/100ns(max) for Vcc=2.7V~3.6V
- CMOS Low operating power
Operating : 45/35/25mA (Icc max)
Standby : 20µA (TYP.) L-version
3µA (TYP.) LL-version
- Single 2.7V~3.6V power supply
- Operating Temperature:
Commercial : 0°C~70°C
Extended : -20°C~80°C
- All inputs and outputs TTL compatible
- Fully static operation
- Three state outputs
- Data retention voltage : 1.5V (min)
- Package : 32 pin 8mm×20 mm TSOP-I
32 pin 8mm×13.4mm STSOP
36 pin 6mm×8mmTFBGA

GENERAL DESCRIPTION

The UT62L2568 is a 2,097,152-bit high speed CMOS static random access memory organized as 262,144 words by 8 bits. It is fabricated using high performance, high reliability CMOS technology.

The UT62L2568 is designed for high speed system applications. It is particularly well suited for battery back-up nonvolatile memory applications.

The UT62L2568 operates from a single 2.7V~3.6V power supply and all inputs and outputs are fully TTL compatible.

PIN DESCRIPTION

SYMBOL	DESCRIPTION
A0 - A17	Address Inputs
I/O1 - I/O8	Data Inputs/Outputs
$\overline{CE1}, CE2$	Chip Enable 1,2 Input
\overline{WE}	Write Enable Input
\overline{OE}	Output Enable Input
Vcc	Power Supply
Vss	Ground
NC	No Connection

FUNCTIONAL BLOCK DIAGRAM

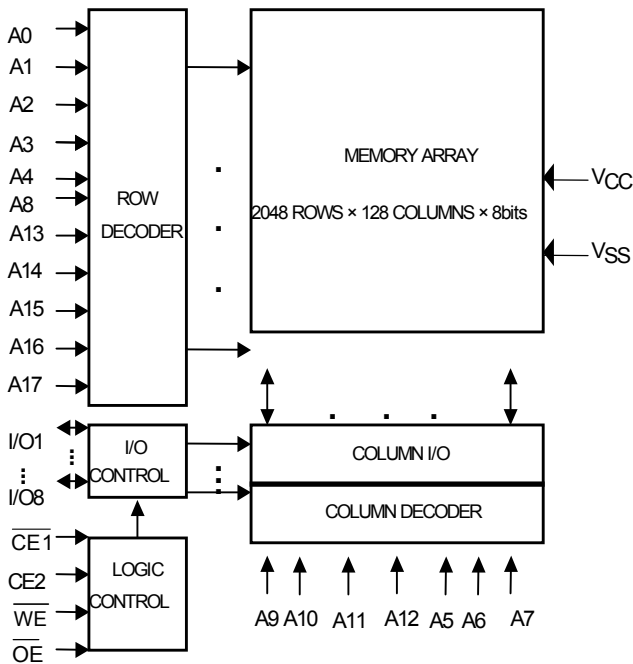



PIN CONFIGURATION

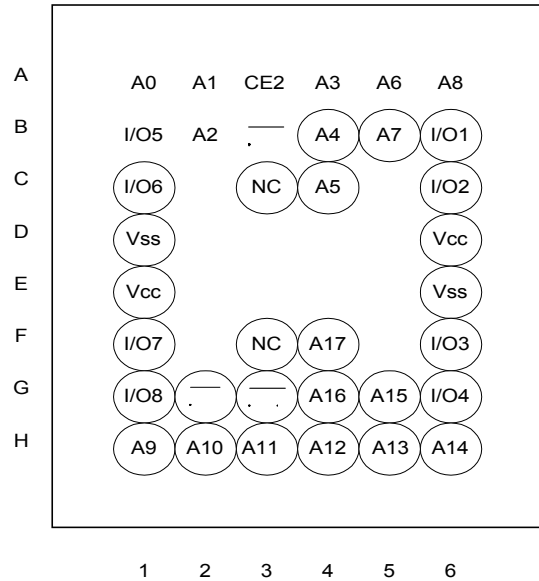
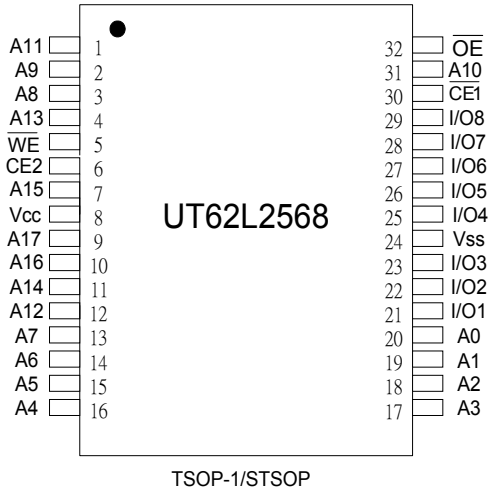

TRUTH TABLE

MODE	CE1	CE2	OE	WE	I/O OPERATION	SUPPLY CURRENT
Standby	H	X	X	X	High - Z	I_{SB}, I_{SB1}
Standby	X	L	X	X	High - Z	I_{SB}, I_{SB1}
Output Disable	L	H	H	H	High - Z	I_{CC}
Read	L	H	L	H	D_{OUT}	I_{CC}
Write	L	H	X	L	D_{IN}	I_{CC}

Note: H = V_{IH} , L = V_{IL} , X = Don't care.

**ABSOLUTE MAXIMUM RATINGS***

PARAMETER		SYMBOL	RATING	UNIT
Terminal Voltage with Respect to V_{SS}		V_{TERM}	-0.5 to 4.6	V
Operating Temperature	Commercial	T_A	0 to 70	°C
	Extended	T_A	-20 to 80	°C
Storage Temperature		T_{STG}	-65 to 150	°C
Power Dissipation		P_D	1	W
DC Output Current		I_{OUT}	50	mA
Soldering Temperature (under 10 secs)		T_{solder}	260	°C

*Stresses greater than those listed under "Absolute Maximum Ratings" may cause permanent damage to the device. This is a stress rating only and functional operation of the device or any other conditions above those indicated in the operational sections of this specification is not implied. Exposure to the absolute maximum rating conditions for extended period may affect device reliability.

DC ELECTRICAL CHARACTERISTICS ($V_{CC} = 2.7V \sim 3.6V$, $T_A = 0^\circ C$ to $70^\circ C$ / $-20^\circ C$ to $80^\circ C$ (E))

PARAMETER	SYMBOL	TEST CONDITION	MIN.	TYP.	MAX.	UNIT	
Power Voltage	V_{CC}		2.7	3.0	3.6	V	
Input High Voltage	V_{IH}		2.0	-	$V_{CC}+0.3$	V	
Input Low Voltage	V_{IL}		-0.2	-	0.6	V	
Input Leakage Current	I_{LI}	$V_{SS} \leq V_{IN} \leq V_{CC}$	-1	-	1	μA	
Output Leakage Current	I_{LO}	$V_{SS} \leq V_{IO} \leq V_{CC}$, Output Disabled	-1	-	1	μA	
Output High Voltage	V_{OH}	$I_{OH} = -1mA$	2.2	-	-	V	
Output Low Voltage	V_{OL}	$I_{OL} = 2mA$	-	-	0.4	V	
Operating Power Supply Current	I_{CC}	Cycle time=Min.100% duty, $\overline{CE1} = V_{IL}$, $CE2 = V_{IH}$, $I_{IO} = 0mA$,	55	-	30	45	mA
			70	-	25	35	mA
			100	-	20	25	mA
	I_{CC1}	Cycle time = $1\mu s$, 100% duty, $\overline{CE1} \leq 0.2V$, $CE2 \geq V_{CC}-0.2V$, $I_{IO} = 0mA$, other pins at 0.2V or $V_{CC}-0.2V$,	-	4	5	mA	
	I_{CC2}	Cycle time = 500ns, 100% duty, $\overline{CE1} \leq 0.2V$, $CE2 \geq V_{CC}-0.2V$, $I_{IO} = 0mA$, other pins at 0.2V or $V_{CC}-0.2V$,	-	8	10	mA	
Standby Current(TTL)	I_{SB1}	$\overline{CE1} = V_{IH}$ or $CE2 = V_{IL}$	-	0.3	0.5	mA	
Standby Current(CMOS)	I_{SB1}	$\overline{CE1} \geq V_{CC}-0.2V$ or $CE2 \leq 0.2V$, other pins at 0.2V or $V_{CC}-0.2V$,	-L	-	20	80	μA
			-LL	-	3	25	μA

**CAPACITANCE** (TA=25°C, f=1.0MHz)

PARAMETER	SYMBOL	MIN.	MAX	UNIT
Input Capacitance	C _{IN}	-	6	pF
Input/Output Capacitance	C _{I/O}	-	8	pF

Note : These parameters are guaranteed by device characterization, but not production tested.

AC TEST CONDITIONS

Input Pulse Levels	0V to 3.0V
Input Rise and Fall Times	5ns
Input and Output Timing Reference Levels	1.5V
Output Load	C _L = 30pF, I _{OH} /I _{OL} = -1mA/2mA

AC ELECTRICAL CHARACTERISTICS (V_{CC} = 2.7V~3.6V, TA = 0°C to 70°C / -20°C to 80°C(E))**(1) READ CYCLE**

PARAMETER	SYMBOL	UT62L2568-55*		UT62L2568-70		UT62L2568-100		UNIT
		MIN.	MAX.	MIN.	MAX.	MIN.	MAX.	
Read Cycle Time	t _{RC}	55	-	70	-	100	-	ns
Address Access Time	t _{AA}	-	55	-	70	-	100	ns
Chip Enable Access Time	t _{ACE1} , t _{ACE2}	-	55	-	70	-	100	ns
Output Enable Access Time	t _{OE}	-	30	-	35	-	50	ns
Chip Enable to Output in Low Z	t _{CLZ1*} , t _{CLZ2*}	10	-	10	-	10	-	ns
Output Enable to Output in Low Z	t _{OLZ*}	5	-	5	-	5	-	ns
Chip Disable to Output in High Z	t _{CHZ1*} , t _{CHZ2*}	-	20	-	25	-	30	ns
Output Disable to Output in High Z	t _{OHZ*}	-	20	-	25	-	35	ns
Output Hold from Address Change	t _{OH}	5	-	5	-	5	-	ns

(2) WRITE CYCLE

PARAMETER	SYMBOL	UT62L2568-55*		UT62L2568-70		UT62L2568-100		UNIT
		MIN.	MAX.	MIN.	MAX.	MIN.	MAX.	
Write Cycle Time	t _{WC}	55	-	70	-	100	-	ns
Address Valid to End of Write	t _{AW}	50	-	60	-	80	-	ns
Chip Enable to End of Write	t _{CW1} , t _{CW2}	50	-	60	-	80	-	ns
Address Set-up Time	t _{AS}	0	-	0	-	0	-	ns
Write Pulse Width	t _{WP}	45	-	55	-	70	-	ns
Write Recovery Time	t _{WR}	0	-	0	-	0	-	ns
Data to Write Time Overlap	t _{DW}	25	-	30	-	40	-	ns
Data Hold from End of Write Time	t _{DH}	0	-	0	-	0	-	ns
Output Active from End of Write	t _{OW*}	5	-	5	-	5	-	ns
Write to Output in High Z	t _{WHZ*}	-	30	-	30	-	40	ns

*These parameters are guaranteed by device characterization, but not production tested.

*55ns for V_{CC}=3.0V~3.6V



TIMING WAVEFORMS

READ CYCLE 1 (Address Controlled) (1,2,4)

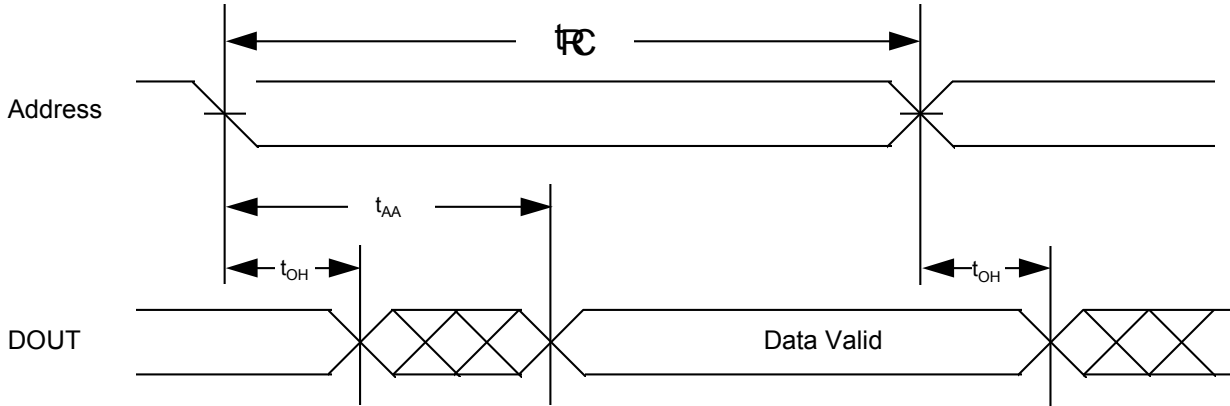

READ CYCLE 2 (\overline{CE} and \overline{OE} Controlled) (1,3,5,6)

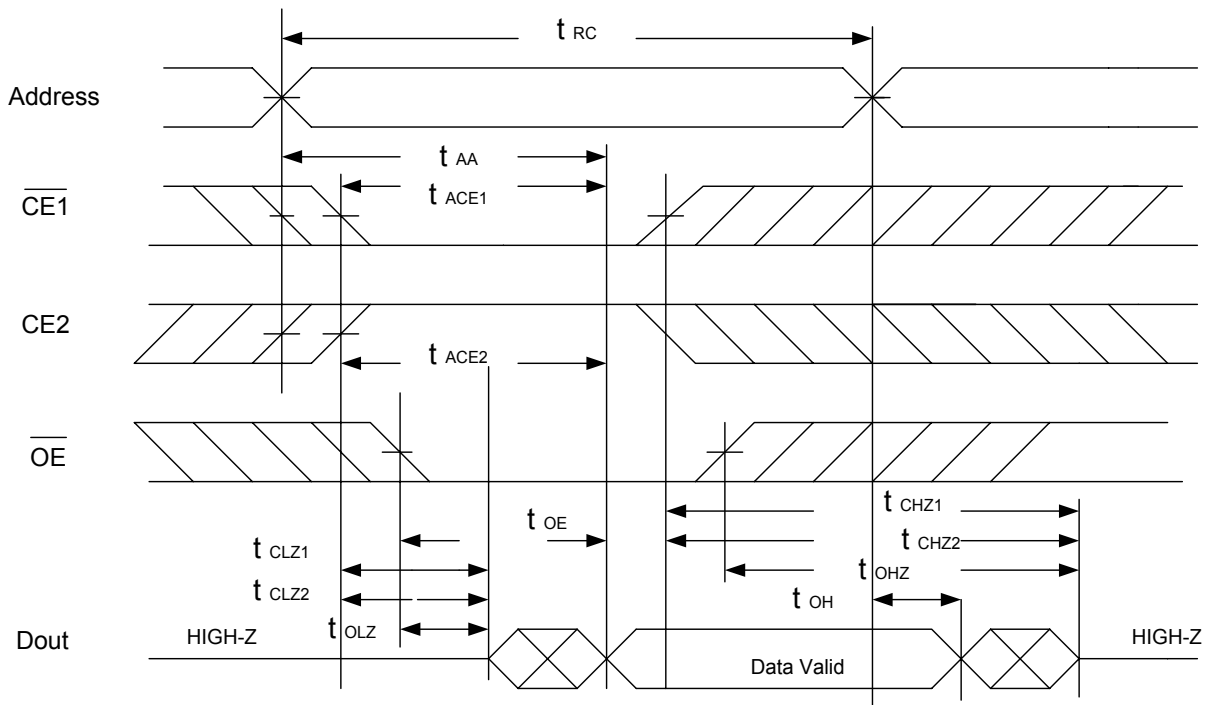

Notes :

1. \overline{WE} is HIGH for read cycle.
2. Device is continuously selected $\overline{CE1}=V_{IL}$ and $CE2=V_{IH}$.
3. Address must be valid prior to or coincident with $\overline{CE1}$ and $CE2$ transition; otherwise t_{AA} is the limiting parameter.
4. \overline{OE} is low.
5. t_{CLZ1} , t_{CLZ2} , t_{OLZ} , t_{CHZ1} , t_{CHZ2} and t_{OHZ} are specified with $C_L=5pF$. Transition is measured $\pm 500mV$ from steady state.
6. At any given temperature and voltage condition, t_{CHZ1} is less than t_{CLZ1} , t_{CHZ2} is less than t_{CLZ2} , t_{OHZ} is less than t_{OLZ} .



WRITE CYCLE 1 (\overline{WE} Controlled) (1,2,3,5)

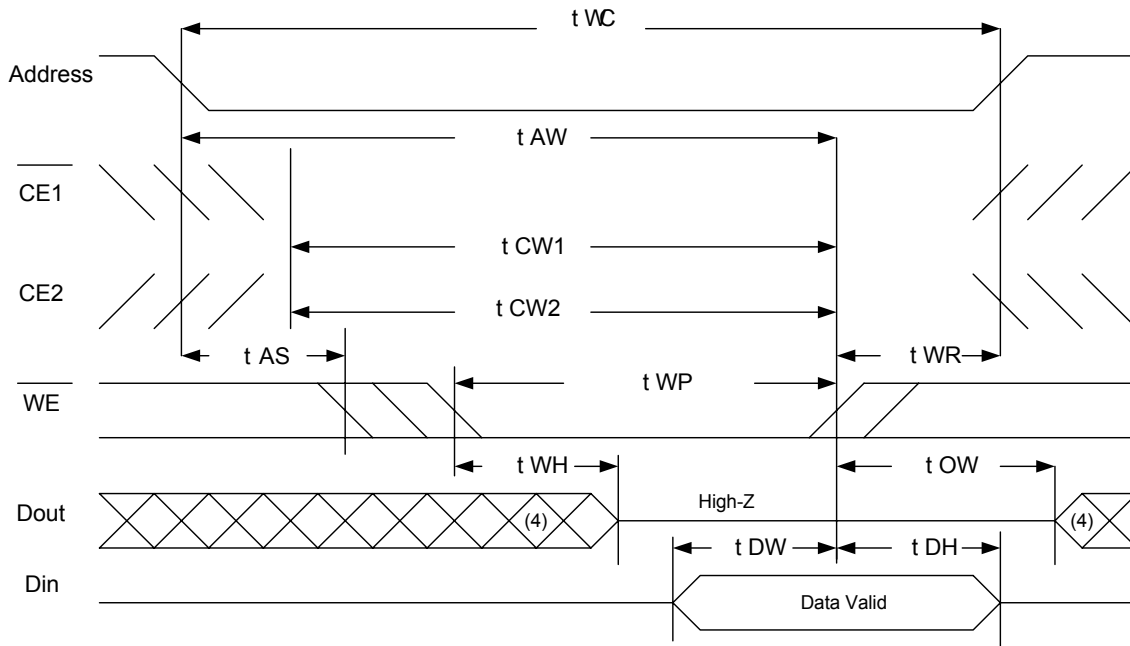

WRITE CYCLE 2 (\overline{CE} Controlled) (1,2,5)

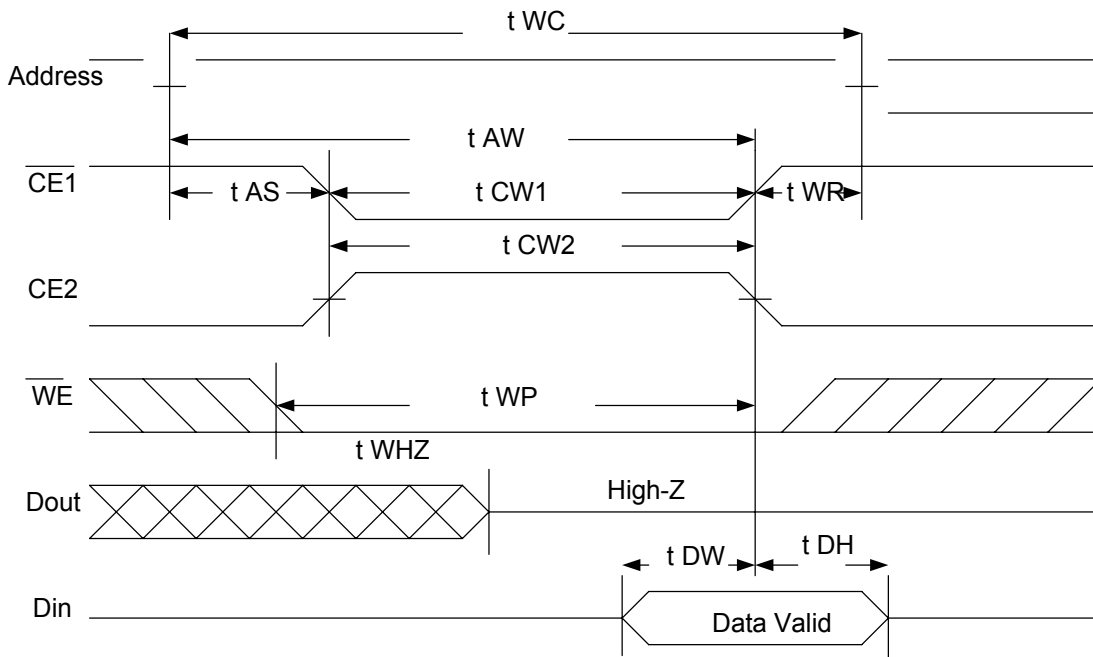

Notes :

1. \overline{WE} or $\overline{CE1}$ must be HIGH or CE2 must be LOW during all address transitions.
2. A write occurs during the overlap of a low $\overline{CE1}$, a high CE2 and a low \overline{WE} .
3. During a \overline{WE} controlled with write cycle with \overline{OE} LOW, t_{WP} must be greater than $t_{WHZ}+t_{DW}$ to allow the I/O drivers to turn off and data to be placed on the bus.
4. During this period, I/O pins are in the output state, and input signals must not be applied.
5. If the $\overline{CE1}$ LOW transition occurs simultaneously with or after \overline{WE} LOW transition, the outputs remain in a high impedance state.
6. t_{OW} and t_{WHZ} are specified with $C_L=5pF$. Transition is measured $\pm 500mV$ from steady state.



DATA RETENTION CHARACTERISTICS (TA = 0°C to 70°C / -20°C to 80°C(E))

PARAMETER	SYMBOL	TEST CONDITION	MIN.	TYP.	MAX.	UNIT	
V _{CC} for Data Retention	V _{DR}	$\overline{CE1} \geq V_{CC}-0.2V$ or $CE2 \leq 0.2V$	1.5	-	3.6	V	
Data Retention Current	I _{DR}	V _{CC} =1.5V $\overline{CE1} \geq V_{CC}-0.2V$ or $CE2 \leq 0.2V$	- L	-	1	50	μA
			- LL	-	0.5	20	μA
Chip Disable to Data Retention Time	t _{CDR}	See Data Retention Waveforms (below)	0	-	-	ms	
Recovery Time	t _R		5	-	-	ms	

DATA RETENTION WAVEFORM

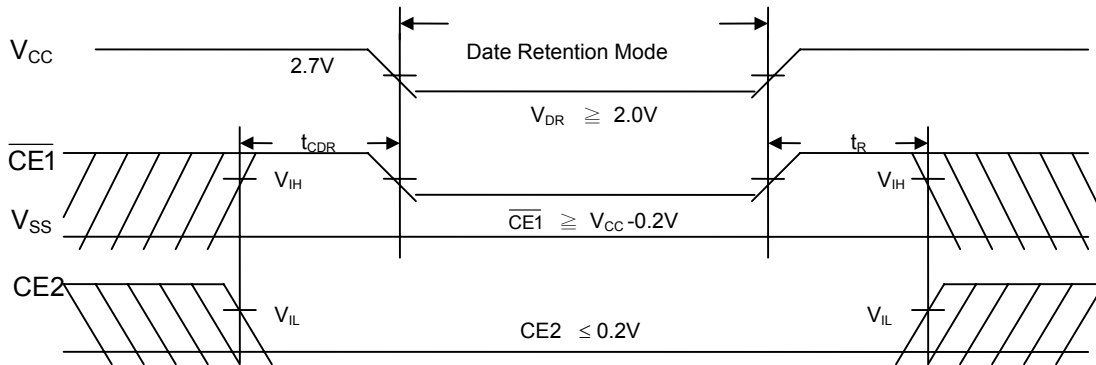



PACKAGE OUTLINE DIMENSION

32 pin 8mm x 20mm TSOP-I Package Outline Dimension

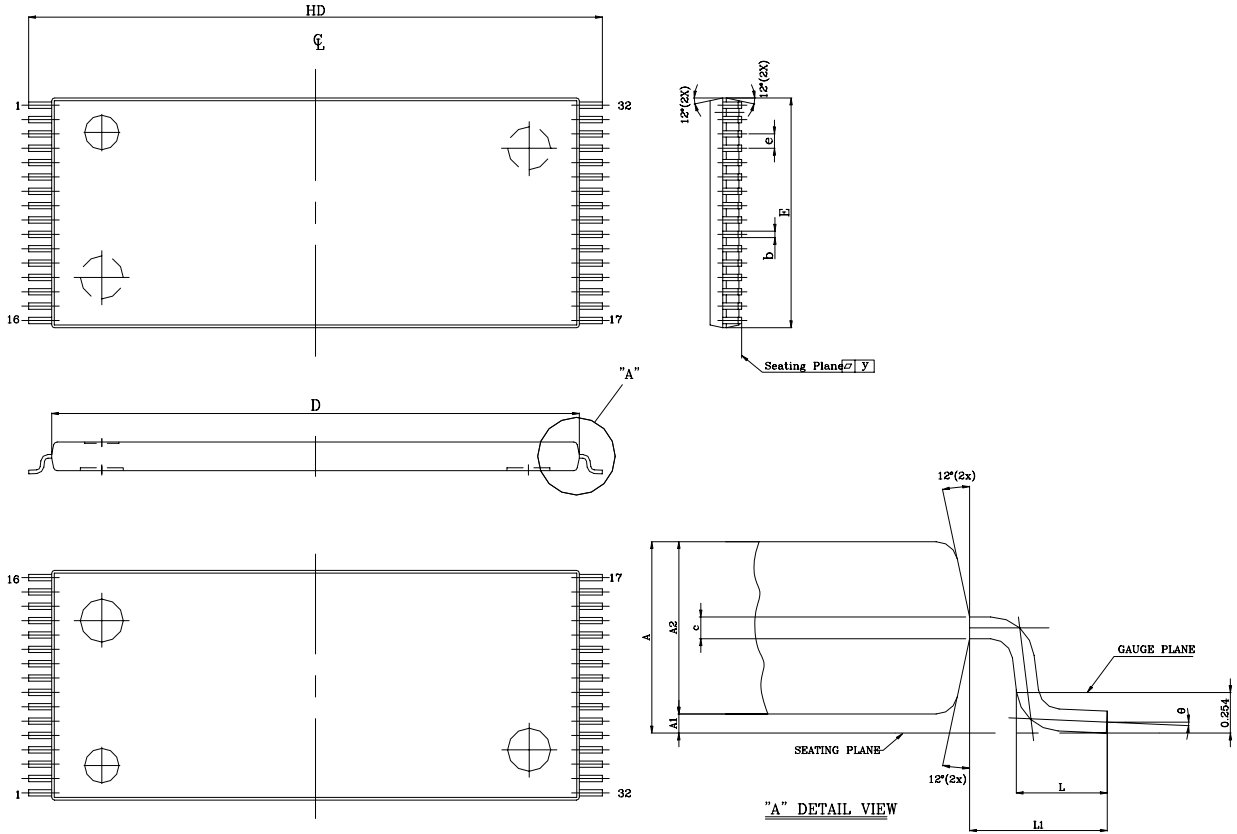

UNIT	INCH(BASE)	MM(REF)
A	0.047 (MAX)	1.20 (MAX)
A1	0.004 ±0.002	0.10 ±0.05
A2	0.039 ±0.002	1.00 ±0.05
b	0.008 + 0.002 - 0.001	0.20 + 0.05 - 0.03
c	0.005 (TYP)	0.127 (TYP)
D	0.724 ±0.004	18.40 ±0.10
E	0.315 ±0.004	8.00 ±0.10
e	0.020 (TYP)	0.50 (TYP)
HD	0.787 ±0.008	20.00 ±0.20
L	0.0197 ±0.004	0.50 ±0.10
L1	0.0315 ±0.004	0.08 ±0.10
y	0.003 (MAX)	0.076 (MAX)
θ	0°~5°	0°~5°



32 pin 8mm x 13.4mm STSOP Package Outline Dimension

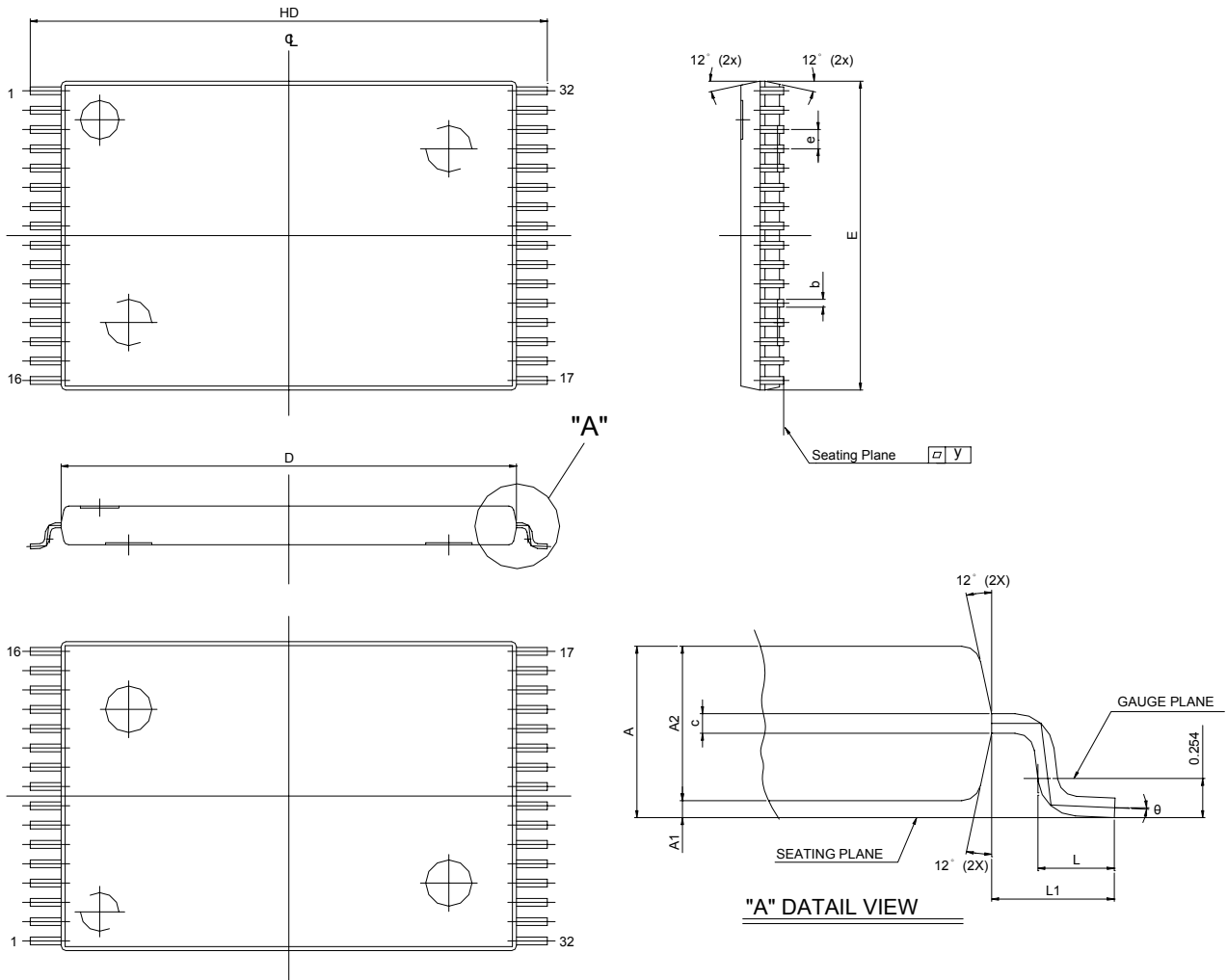

SYMBOL \ UNIT	INCH(BASE)	MM(REF)
A	0.049 (MAX)	1.25 (MAX)
A1	0.005 ±0.002	0.130 ±0.05
A2	0.039 ±0.002	1.00 ±0.05
b	0.008 ±0.01	0.20±0.025
c	0.005 (TYP)	0.127 (TYP)
D	0.465 ±0.004	11.80 ±0.10
E	0.315 ±0.004	8.00 ±0.10
e	0.020 (TYP)	0.50 (TYP)
HD	0.528±0.008	13.40 ±0.20.
L	0.0197 ±0.004	0.50 ±0.10
L1	0.0315 ±0.004	0.8 ±0.10
y	0.003 (MAX)	0.076 (MAX)
θ	0°~5°	0°~5°





36 pin 6mmx8mm TFBGA Package Outline Dimension

A1 Ball Pad Corner

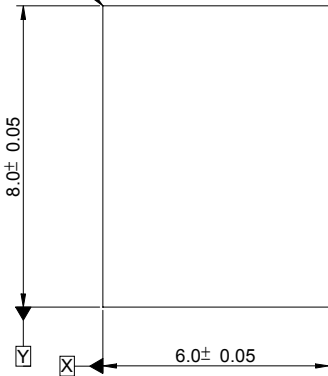

TOP VIEW (DIE VIEW)

A1 Ball Pad Corner

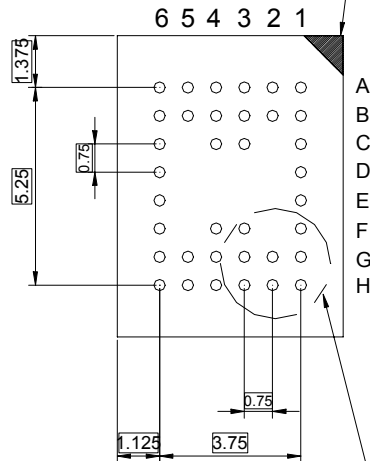

DETAIL A

BOTTOM VIEW (BALL SIDE)

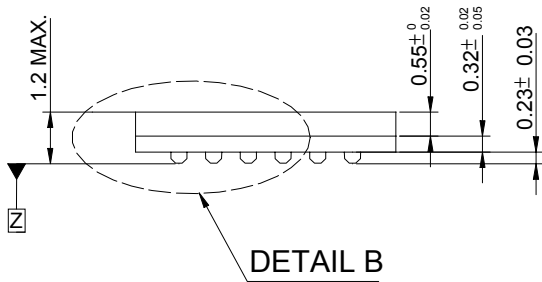

DETAIL B

SIDE VIEW

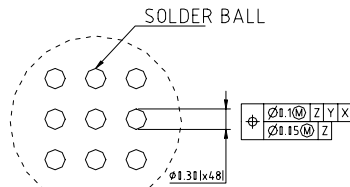

DETAIL A

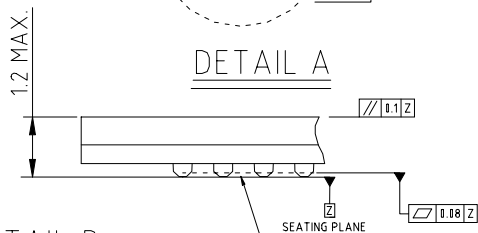

DETAIL B



ORDERING INFORMATION

COMMERCIAL TEMPERATURE

PART NO.	ACCESS TIME (ns)	STANDBY CURRENT (µA) TYP.	PACKAGE
UT62L2568LC-55L	55	20	32 PIN TSOP- I
UT62L2568LC-55LL	55	3	32 PIN TSOP- I
UT62L2568LC-70L	70	20	32 PIN TSOP- I
UT62L2568LC-70LL	70	3	32 PIN TSOP- I
UT62L2568LS-55L	55	20	32 PIN STSOP
UT62L2568LS-55LL	55	3	32 PIN STSOP
UT62L2568LS-70L	70	20	32 PIN STSOP
UT62L2568LS-70LL	70	3	32 PIN STSOP
UT62L2568BS-55L	55	20	36 PIN TFBGA
UT62L2568BS-55LL	55	3	36 PIN TFBGA
UT62L2568BS-70L	70	20	36 PIN TFBGA
UT62L2568BS-70LL	70	3	36 PIN TFBGA

EXTENDED TEMPERATURE

PART NO.	ACCESS TIME (ns)	STANDBY CURRENT (µA) TYP.	PACKAGE
UT62L2568LC-55LE	55	20	32 PIN TSOP- I
UT62L2568LC-55LLE	55	3	32 PIN TSOP- I
UT62L2568LC-70LE	70	20	32 PIN TSOP- I
UT62L2568LC-70LLE	70	3	32 PIN TSOP- I
UT62L2568LS-55LE	55	20	32 PIN STSOP
UT62L2568LS-55LLE	55	3	32 PIN STSOP
UT62L2568LS-70LE	70	20	32 PIN STSOP
UT62L2568LS-70LLE	70	3	32 PIN STSOP
UT62L2568BS-55LE	55	20	36 PIN TFBGA
UT62L2568BS-55LLE	55	3	36 PIN TFBGA
UT62L2568BS-70LE	70	20	36 PIN TFBGA
UT62L2568BS-70LLE	70	3	36 PIN TFBGA



UTRON

Preliminary Rev. 0.1

UT62L2568

256K X 8 BIT LOW POWER CMOS SRAM

REVISION HISTORY

REVISION	DESCRIPTION	DATE
Preliminary Rev. 0.1	Original.	Jun 18, 2001