



FEATURES

- Fast access time :
  - 55ns(max.) for Vcc=2.7V~3.6V
  - 70ns(max.) for Vcc=2.5V~3.6V
- CMOS Low operating power
  - Operating : 40/25mA (Icc max.)
  - Standby : TA=0°C~50°C
    - 20 uA(max.) L -version
    - 3 uA(max.) LL-version
- Single 2.5V~3.6V power supply
- Operating temperature:
  - Industrial : -40°C~85°C
- All inputs and outputs TTL compatible
- Fully static operation
- Three state outputs
- Data retention voltage: 1.5V (min)
- Package : 32-pin 8mm x 20mm TSOP- I
  - 32-pin 8mm x 13.4mm STSOP
  - 36-pin 6mm x 8mm TFBGA

GENERAL DESCRIPTION

The UT62L2568 is a 2,097,152-bit low power CMOS static random access memory organized as 262,144 words by 8 bits. It is fabricated using high performance, high reliability CMOS technology.

The UT62L2568 is designed for very low power system applications. It is particularly well suited for battery back-up nonvolatile memory applications.

It operates from a wide range of 2.5V~ 3.6V supply voltage. Easy memory expansion is provided by using two chip enable input ( $\overline{CE1}$ ,  $\overline{CE2}$ ). And all inputs and three-state outputs are fully TTL compatible.

FUNCTIONAL BLOCK DIAGRAM

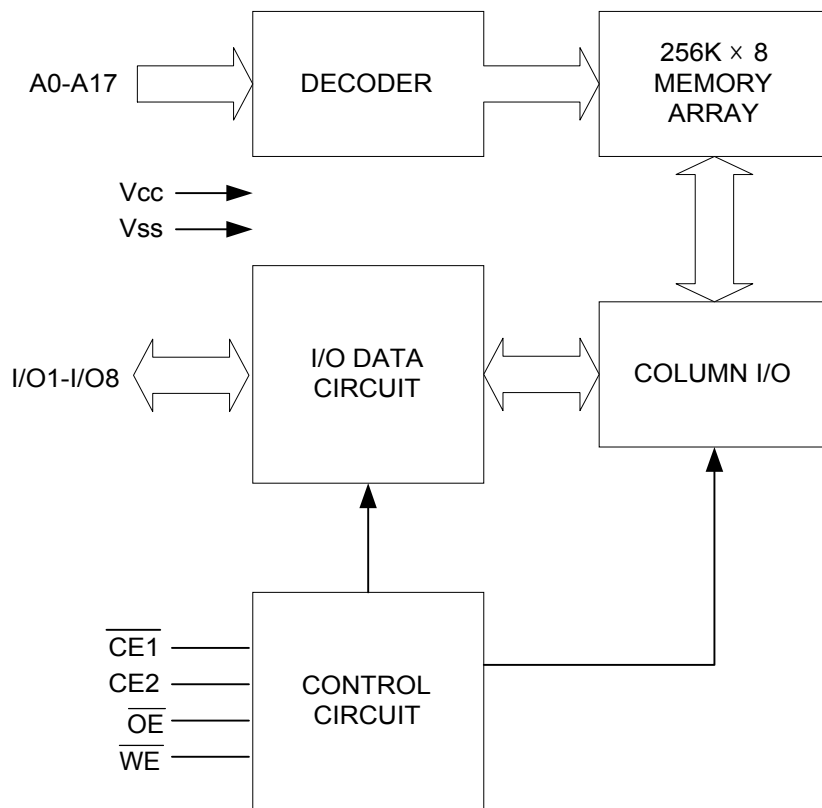



### PIN CONFIGURATION

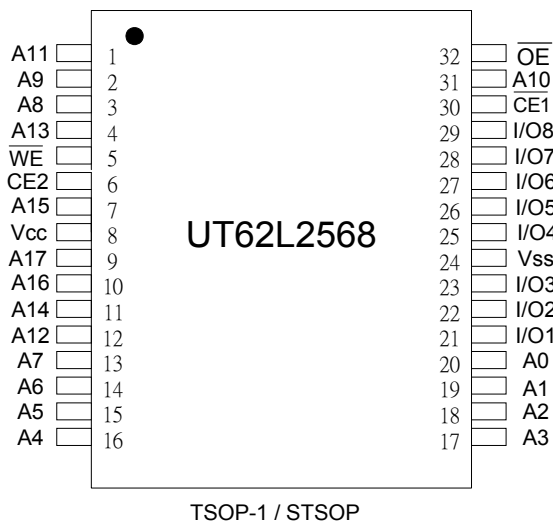
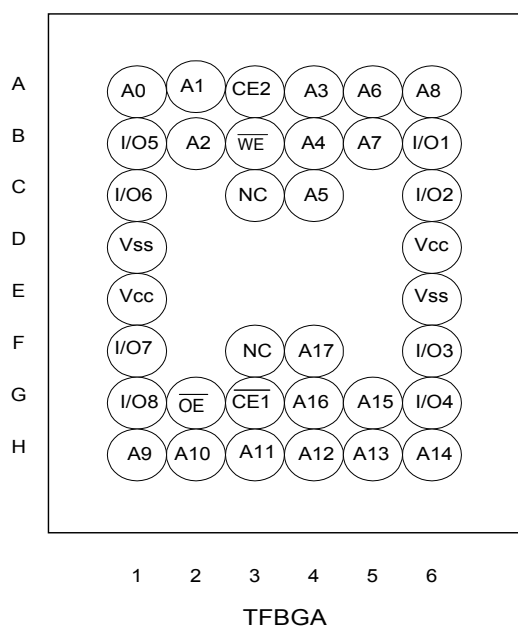

### PIN DESCRIPTION

SYMBOL	DESCRIPTION
A0 - A17	Address Inputs
I/O1 - I/O8	Data Inputs/Outputs
CE1, CE2	Chip Enable Inputs
WE	Write Enable Input
OE	Output Enable Input
V <sub>CC</sub>	Power Supply
V <sub>SS</sub>	Ground
NC	No Connection



**TRUTH TABLE**

MODE	CE1	CE2	OE	WE	I/O OPERATION	SUPPLY CURRENT
Standby	H	X	X	X	High - Z	$I_{SB}, I_{SB1}, I_{SB2}$
	X	L	X	X	High - Z	$I_{SB}, I_{SB1}, I_{SB2}$
Output Disable	L	H	H	H	High - Z	$I_{CC}, I_{CC1}, I_{CC2}$
Read	L	H	L	H	$D_{OUT}$	$I_{CC}, I_{CC1}, I_{CC2}$
Write	L	H	X	L	$D_{IN}$	$I_{CC}, I_{CC1}, I_{CC2}$

Note: H =  $V_{IH}$ , L= $V_{IL}$ , X = Don't care.

**ABSOLUTE MAXIMUM RATINGS\***

PARAMETER	SYMBOL	RATING	UNIT
Terminal Voltage with Respect to $V_{SS}$	$V_{TERM}$	-0.5 to $V_{CC}+0.3V$	V
Operating Temperature Industrial	$T_A$	-40 to 85	$^{\circ}C$
Storage Temperature	$T_{STG}$	-65 to 150	$^{\circ}C$
Power Dissipation	$P_D$	1	W
DC Output Current	$I_{OUT}$	50	mA
Soldering Temperature (under 10 secs)	$T_{solder}$	260	$^{\circ}C$

\*Stresses greater than those listed under "Absolute Maximum Ratings" may cause permanent damage to the device. This is a stress rating only and functional operation of the device or any other conditions above those indicated in the operational sections of this specification is not implied. Exposure to the absolute maximum rating conditions for extended period may affect device reliability.

**DC ELECTRICAL CHARACTERISTICS ( $V_{CC} = 2.5V \sim 3.6V, T_A = -40^{\circ}C$  to  $85^{\circ}C$ )**

PARAMETER	SYMBOL	TEST CONDITION	MIN.	TYP.	MAX.	UNIT	
Power Voltage	$V_{CC}$		2.5	3.0	3.6	V	
Input High Voltage	$V_{IH}$		2.2	-	$V_{CC}+0.3$	V	
Input Low Voltage	$V_{IL}$		-0.3	-	0.6	V	
Input Leakage Current	$I_{LI}$	$V_{SS} \leq V_{IN} \leq V_{CC}$	-1	-	1	$\mu A$	
Output Leakage Current	$I_{LO}$	$V_{SS} \leq V_{IO} \leq V_{CC}$ , Output Disabled	-1	-	1	$\mu A$	
Output High Voltage	$V_{OH}$	$I_{OH} = -1mA$	2.2	-	-	V	
Output Low Voltage	$V_{OL}$	$I_{OL} = 2.1mA$	-	-	0.4	V	
Operating Current	$I_{CC}$	Cycle time=Min.100% duty, $\overline{CE1} = V_{IL}, CE2 = V_{IH}, I_{IO} = 0mA$	55	-	25	40	mA
			70	-	15	25	mA
	$I_{CC1}$	Cycle time = $1\mu s$ , 100% duty, $\overline{CE1} \leq 0.2V, CE2 \geq V_{CC}-0.2V, I_{IO} = 0mA$ , other pins at 0.2V or $V_{CC}-0.2V$ ,	-	4	5	mA	
$I_{CC2}$	Cycle time = 500ns, 100% duty, $\overline{CE1} \leq 0.2V, CE2 \geq V_{CC}-0.2V, I_{IO} = 0mA$ , other pins at 0.2V or $V_{CC}-0.2V$ ,	-	8	10	mA		
Standby Current (TTL)	$I_{SB}$	$\overline{CE1} = V_{IH}$ or $CE2 = V_{IL}$	-	0.3	0.5	mA	
Standby Current (CMOS)	$I_{SB1}$	$\overline{CE1} \geq V_{CC}-0.2V$ or $CE2 \leq 0.2V$ , other pins at 0.2V or $V_{CC}-0.2V$ , $T_A = 0^{\circ}C \sim 50^{\circ}C$	-L	-	-	20	$\mu A$
			-LL	-	-	3	$\mu A$
	$I_{SB2}$	$\overline{CE1} \geq V_{CC}-0.2V$ or $CE2 \leq 0.2V$ , other pins at 0.2V or $V_{CC}-0.2V$ , $T_A = -40^{\circ}C \sim 85^{\circ}C$	-L	-	-	80	$\mu A$
			-LL	-	-	10	$\mu A$

**CAPACITANCE** ( $T_A=25^\circ\text{C}$ ,  $f=1.0\text{MHz}$ )

PARAMETER	SYMBOL	MIN.	MAX	UNIT
Input Capacitance	$C_{IN}$	-	6	pF
Input/Output Capacitance	$C_{I/O}$	-	8	pF

Note : These parameters are guaranteed by device characterization, but not production tested.

**AC TEST CONDITIONS**

Input Pulse Levels	0V to 3V
Input Rise and Fall Times	5ns
Input and Output Timing Reference Levels	1.5V
Output Load	$C_L = 30\text{pF}+1\text{TTL}$ , $I_{OH} = -1\text{mA}$ , $I_{OL} = 2.1\text{mA}$

**AC ELECTRICAL CHARACTERISTICS** ( $T_A = -40^\circ\text{C}$  to  $85^\circ\text{C}$ )**(1) READ CYCLE**

PARAMETER	SYMBOL	UT62L2568-55 $V_{CC} = 2.7\text{V}\sim 3.6\text{V}$		UT62L2568-70 $V_{CC} = 2.5\text{V}\sim 3.6\text{V}$		UNIT
		MIN.	MAX.	MIN.	MAX.	
Read Cycle Time	$t_{RC}$	55	-	70	-	ns
Address Access Time	$t_{AA}$	-	55	-	70	ns
Chip Enable Access Time	$t_{ACE1}$ , $t_{ACE2}$	-	55	-	70	ns
Output Enable Access Time	$t_{OE}$	-	30	-	35	ns
Chip Enable to Output in Low Z	$t_{CLZ1^*}$ , $t_{CLZ2^*}$	10	-	10	-	ns
Output Enable to Output in Low Z	$t_{OLZ^*}$	5	-	5	-	ns
Chip Disable to Output in High Z	$t_{CHZ1^*}$ , $t_{CHZ2^*}$	-	20	-	25	ns
Output Disable to Output in High Z	$t_{OHZ^*}$	-	20	-	25	ns
Output Hold from Address Change	$t_{OH}$	10	-	10	-	ns

**(2) WRITE CYCLE**

PARAMETER	SYMBOL	UT62L2568-55 $V_{CC} = 2.7\text{V}\sim 3.6\text{V}$		UT62L2568-70 $V_{CC} = 2.5\text{V}\sim 3.6\text{V}$		UNIT
		MIN.	MAX.	MIN.	MAX.	
Write Cycle Time	$t_{WC}$	55	-	70	-	ns
Address Valid to End of Write	$t_{AW}$	50	-	60	-	ns
Chip Enable to End of Write	$t_{CW1}$ , $t_{CW2}$	50	-	60	-	ns
Address Set-up Time	$t_{AS}$	0	-	0	-	ns
Write Pulse Width	$t_{WP}$	45	-	55	-	ns
Write Recovery Time	$t_{WR}$	0	-	0	-	ns
Data to Write Time Overlap	$t_{DW}$	25	-	30	-	ns
Data Hold from End of Write Time	$t_{DH}$	0	-	0	-	ns
Output Active from End of Write	$t_{OW^*}$	5	-	5	-	ns
Write to Output in High Z	$t_{WHZ^*}$	-	30	-	30	ns

\*These parameters are guaranteed by device characterization, but not production tested.



TIMING WAVEFORMS

READ CYCLE 1 (Address Controlled) (1,2,4)

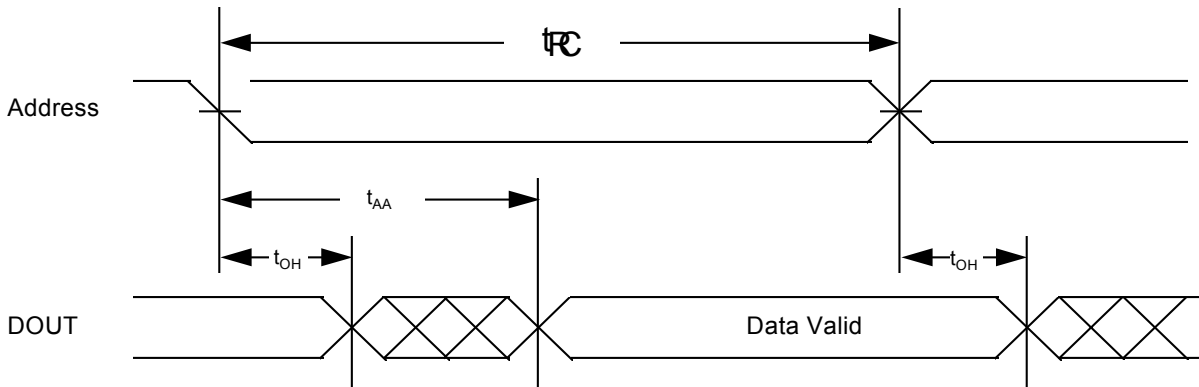

READ CYCLE 2 ( $\overline{CE1}$ , CE2 and  $\overline{OE}$  Controlled) (1,3,5,6)

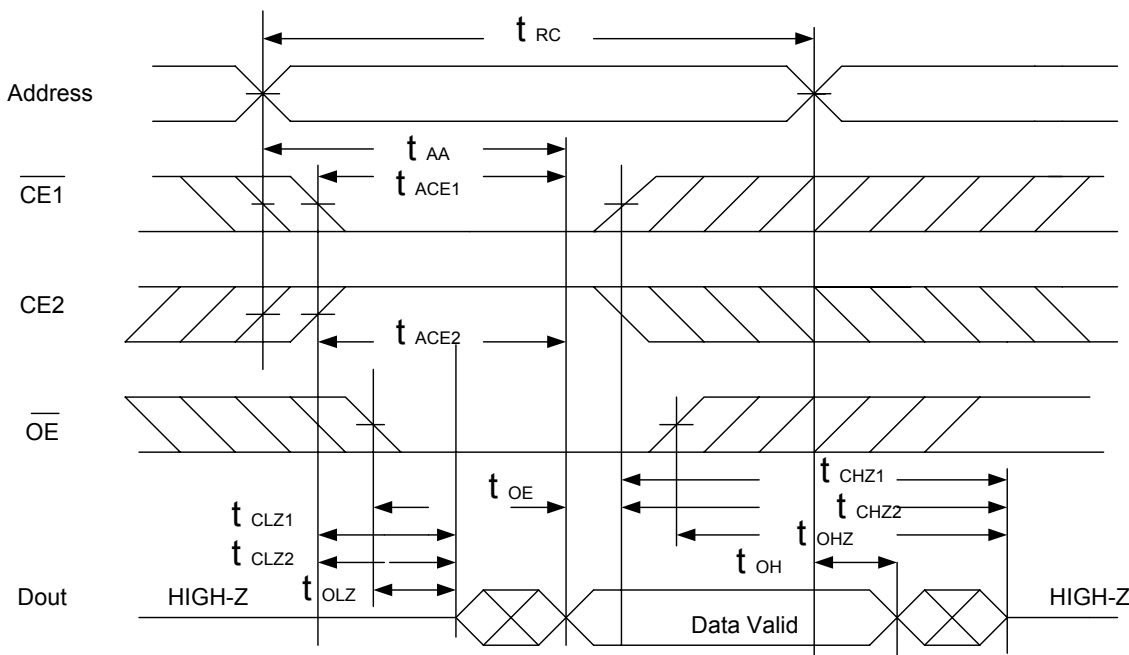

Notes :

1.  $\overline{WE}$  is HIGH for a read cycle.
2. Device is continuously selected  $\overline{OE}$ ,  $\overline{CE1}=V_{IL}$  and  $CE2=V_{IH}$ .
3. Address must be valid prior to or coincident with  $\overline{CE1}$  low and CE2 high transition; otherwise  $t_{AA}$  is the limiting parameter.
4.  $\overline{OE}$  is low.
5.  $t_{CLZ1}$ ,  $t_{CLZ2}$ ,  $t_{OLZ}$ ,  $t_{CHZ1}$ ,  $t_{CHZ2}$  and  $t_{OHZ}$  are specified with  $C_L=5pF$ . Transition is measured  $\pm 500mV$  from steady state.
6. At any given temperature and voltage condition,  $t_{CHZ1}$  is less than  $t_{CLZ1}$ ,  $t_{CHZ2}$  is less than  $t_{CLZ2}$ ,  $t_{OHZ}$  is less than  $t_{OLZ}$ .



WRITE CYCLE 1 ( $\overline{WE}$  Controlled) (1,2,3,5)

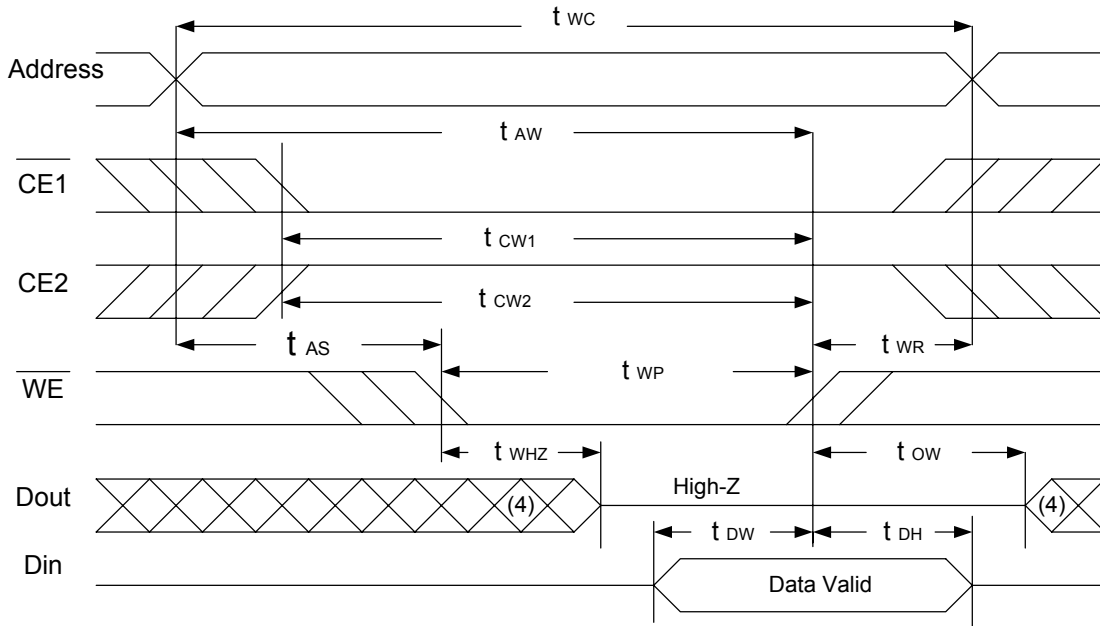

WRITE CYCLE 2 ( $\overline{CE1}$  and  $\overline{CE2}$  Controlled) (1,2,5)

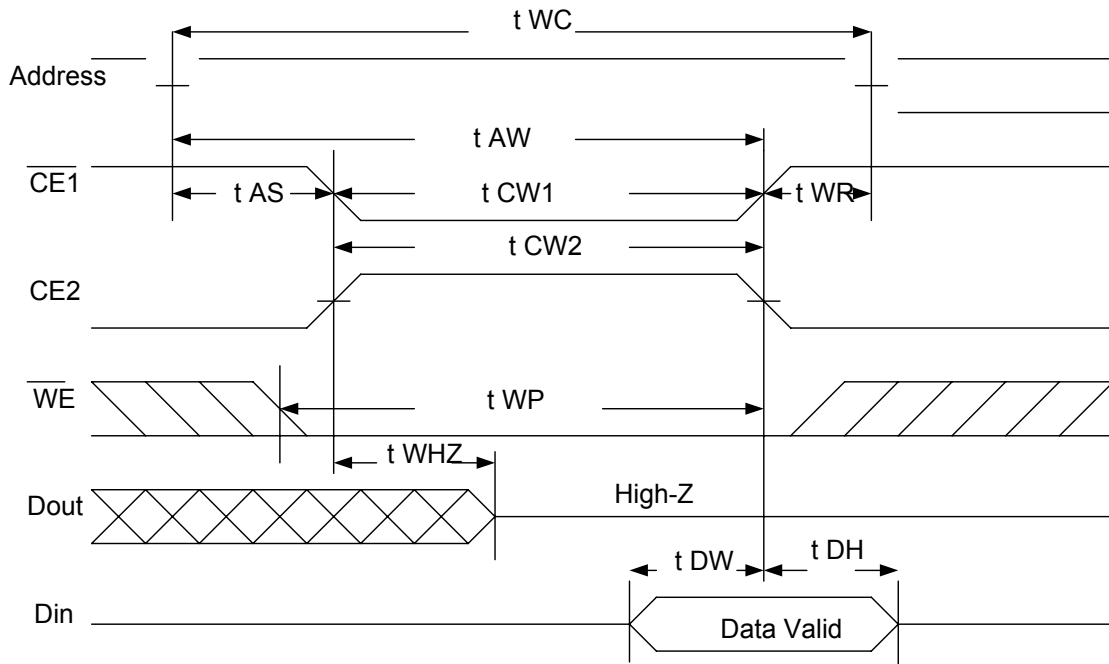

Notes :

1.  $\overline{WE}$  or  $\overline{CE1}$  must be HIGH or  $\overline{CE2}$  must be LOW during all address transitions.
2. A write occurs during the overlap of a low  $\overline{CE1}$ , a high  $\overline{CE2}$  and a low  $\overline{WE}$ .
3. During a  $\overline{WE}$  controlled with write cycle with  $\overline{OE}$  LOW,  $t_{WP}$  must be greater than  $t_{WHZ}+t_{DW}$  to allow the I/O drivers to turn off and data to be placed on the bus.
4. During this period, I/O pins are in the output state, and input signals must not be applied.
4. If the  $\overline{CE1}$  LOW transition occurs simultaneously with or after  $\overline{WE}$  LOW transition, the outputs remain in a high Impedance state.
6.  $t_{OW}$  and  $t_{WHZ}$  are specified with  $C_L=5pF$ . Transition is measured  $\pm 500mV$  from steady state.



DATA RETENTION CHARACTERISTICS (T<sub>A</sub> = - 40°C to 85°C)

PARAMETER	SYMBOL	TEST CONDITION	MIN.	TYP.	MAX.	UNIT
V <sub>CC</sub> for Data Retention	V <sub>DR</sub>	$\overline{CE} \geq V_{CC}-0.2V$	1.5	-	3.6	V
Data Retention Current	I <sub>DR</sub>	V <sub>CC</sub> =1.5V $\overline{CE} \geq V_{CC}-0.2V$	- L	-	80	μA
			- LL	-	25	μA
Chip Disable to Data Retention Time	t <sub>CDR</sub>	See Data Retention Waveforms (below)	0	-	-	ms
Recovery Time	t <sub>R</sub>		5	-	-	ms

DATA RETENTION WAVEFORM

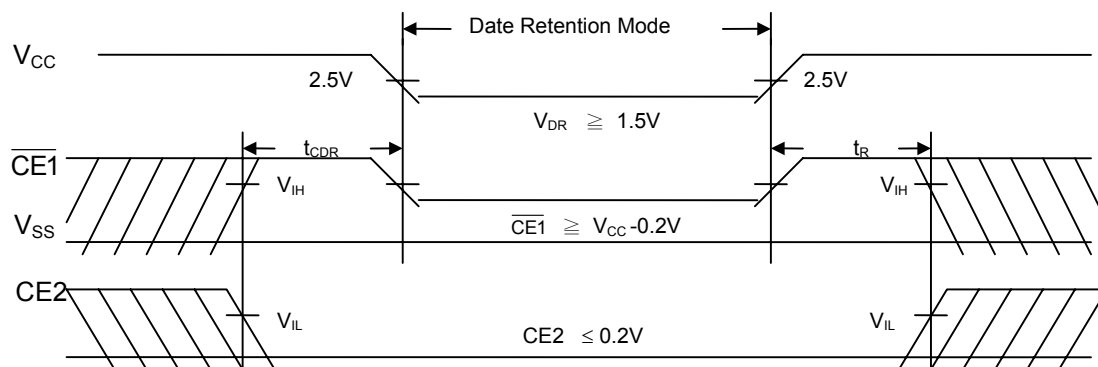



PACKAGE OUTLINE DIMENSION

32 pin 8mm x 20mm TSOP-I Package Outline Dimension

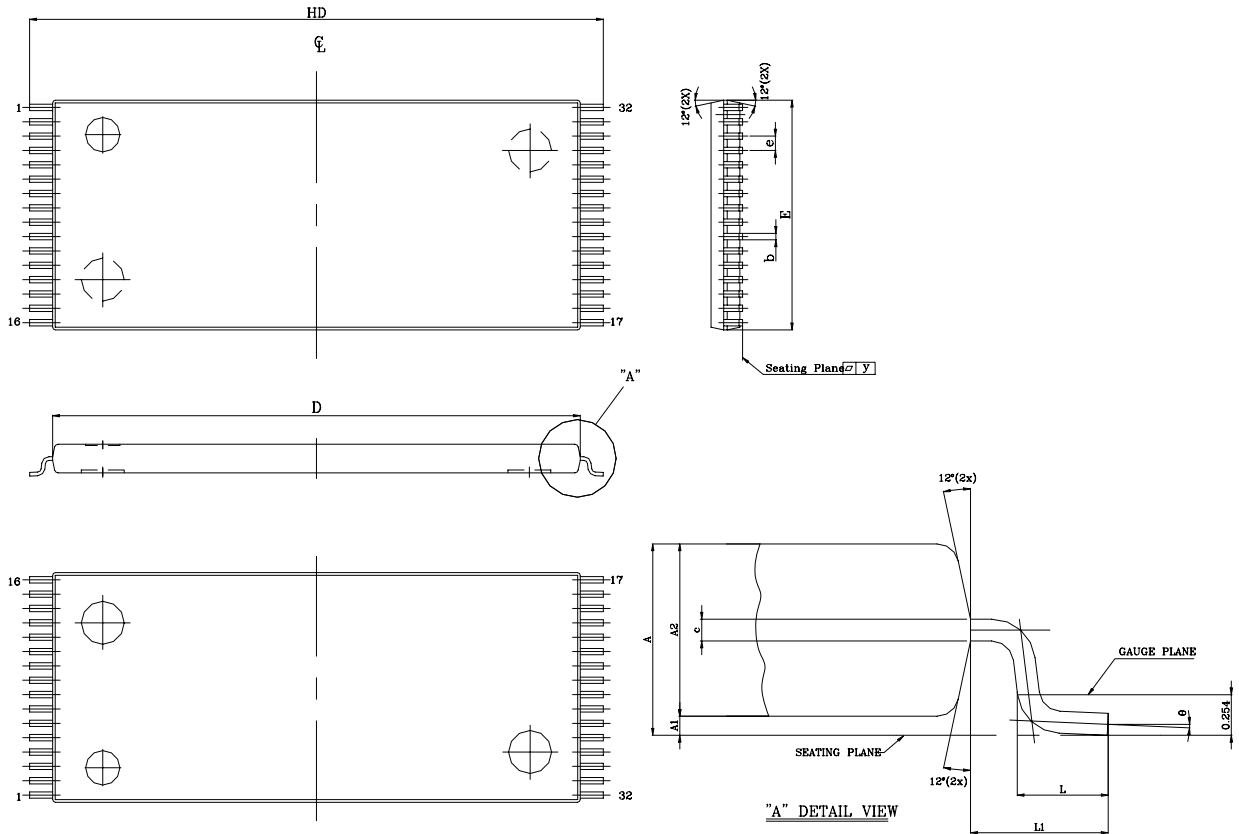

UNIT	INCH(BASE)	MM(REF)
A	0.047 (MAX)	1.20 (MAX)
A1	0.004 ±0.002	0.10 ±0.05
A2	0.039 ±0.002	1.00 ±0.05
b	0.008 + 0.002 - 0.001	0.20 + 0.05 - 0.03
c	0.005 (TYP)	0.127 (TYP)
D	0.724 ±0.004	18.40 ±0.10
E	0.315 ±0.004	8.00 ±0.10
e	0.020 (TYP)	0.50 (TYP)
HD	0.787 ±0.008	20.00 ±0.20
L	0.0197 ±0.004	0.50 ±0.10
L1	0.0315 ±0.004	0.08 ±0.10
y	0.003 (MAX)	0.076 (MAX)
θ	0°~5°	0°~5°





32 pin 8mm x 13.4mm STSOP Package Outline Dimension

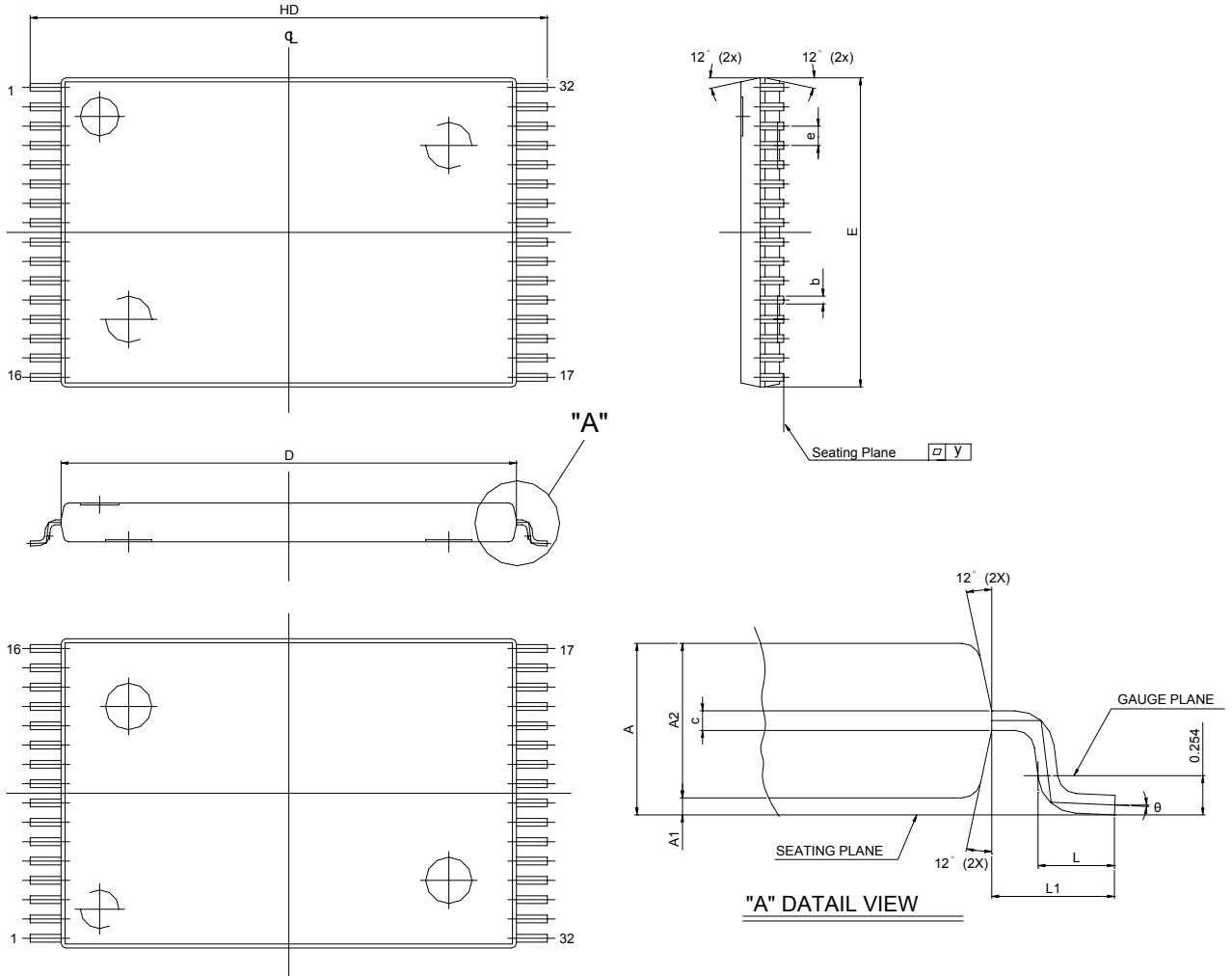

SYMBOL \ UNIT	INCH(BASE)	MM(REF)
A	0.049 (MAX)	1.25 (MAX)
A1	0.005 ±0.002	0.130 ±0.05
A2	0.039 ±0.002	1.00 ±0.05
b	0.008 ±0.01	0.20±0.025
c	0.005 (TYP)	0.127 (TYP)
D	0.465 ±0.004	11.80 ±0.10
E	0.315 ±0.004	8.00 ±0.10
e	0.020 (TYP)	0.50 (TYP)
HD	0.528±0.008	13.40 ±0.20.
L	0.0197 ±0.004	0.50 ±0.10
L1	0.0315 ±0.004	0.8 ±0.10
y	0.003 (MAX)	0.076 (MAX)
θ	0°~5°	0°~5°





36 pin 6mm×8mm TFBGA Package Outline Dimension

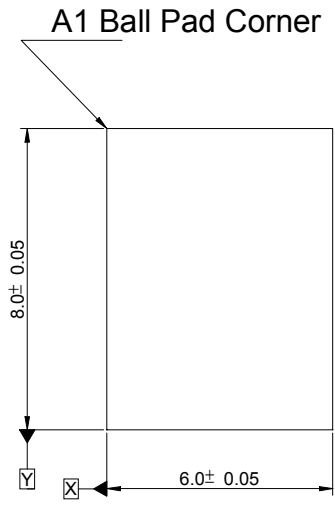

TOP VIEW (DIE VIEW)

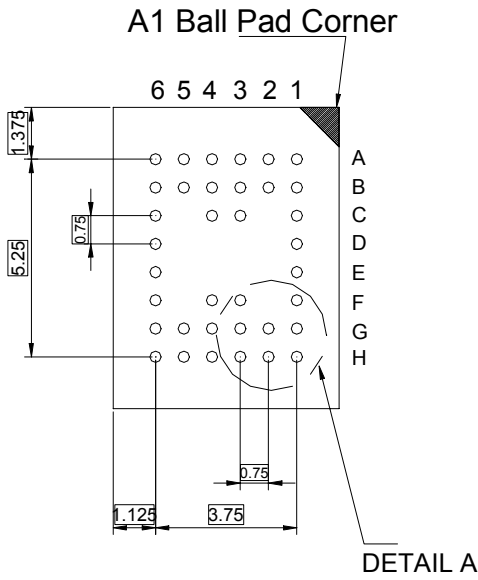

BOTTOM VIEW ( BALL SIDE )

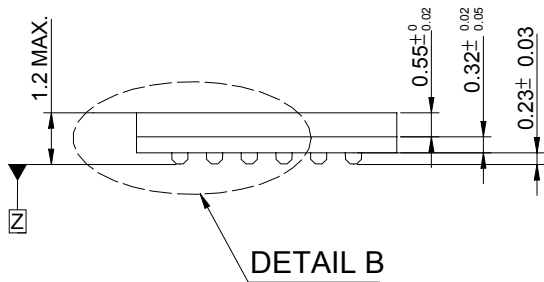

SIDE VIEW

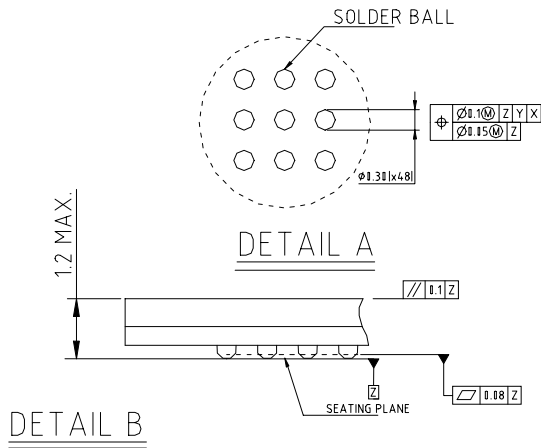



UTRON

Preliminary Rev. 0.1

UT62L2568(I)

256K X 8 BIT LOW POWER CMOS SRAM

## ORDERING INFORMATION

### INDUSTRIAL TEMPERATURE

PART NO.	ACCESS TIME (ns)	STANDBY CURRENT ( $\mu$ A) max. $T_A = 0^\circ\text{C} \sim 50^\circ\text{C}$	PACKAGE
UT62L2568LC-55LI	55	20	32 PIN TSOP- I
UT62L2568LC-55LLI	55	3	32 PIN TSOP- I
UT62L2568LC-70LI	70	20	32 PIN TSOP- I
UT62L2568LC-70LLI	70	3	32 PIN TSOP- I
UT62L2568LS-55LI	55	20	32 PIN STSOP
UT62L2568LS-55LLI	55	3	32 PIN STSOP
UT62L2568LS-70LI	70	20	32 PIN STSOP
UT62L2568LS-70LLI	70	3	32 PIN STSOP
UT62L2568BS-55LI	55	20	36 PIN TFBGA
UT62L2568BS-55LLI	55	3	36 PIN TFBGA
UT62L2568BS-70LI	70	20	36 PIN TFBGA
UT62L2568BS-70LLI	70	3	36 PIN TFBGA



**UTRON**

Preliminary Rev. 0.1

**UT62L2568(I)**

**256K X 8 BIT LOW POWER CMOS SRAM**

---

**REVISION HISTORY**

<b>REVISION</b>	<b>DESCRIPTION</b>	<b>DATE</b>
Preliminary Rev. 0.1	Original.	Nov 28, 2001