

FlatPAC™

50 to 600W Autoranging AC-DC Switchers

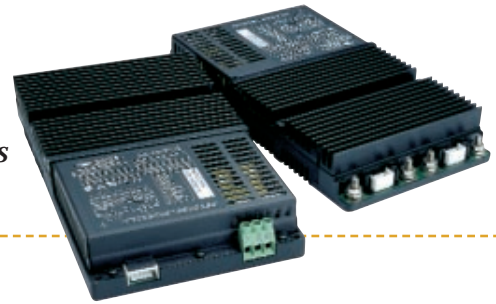

Product Highlights

If you're looking for the convenience of a complete, low profile, agency-approved switching power supply, look no further. The FlatPAC combines Vicor's workhorse VI-200 family of DC-DC converters with a modular package and front end subassembly to provide from 50 to 600W of output power from one to three outputs.

A flat plate heatsink for use in conduction cooled applications may be specified as an alternate to the standard finned version by adding "CC" to the end of the model number.

Vicor's FlatPAC is also available with a current controlled output using BatMod converter modules of 12, 24, or 48Vdc outputs. This option is specified by appending "BM" or "BC" (for conduction cooled versions) to the end of the FlatPAC model number.

The FlatPAC's contemporary design allows us to configure your order quickly and provide rapid turnaround on standard models. It is truly a complete power solution, enabling you to spend more time designing your system and less time worrying about how to power it.

Features

- Microcontroller architecture
- Inputs: 115/230Vac autoranging
- Meets FCC Part 15, EN55022, Class B conducted emissions
- 80-90% efficiency
- Any output: 1 to 95Vdc
- Module enable/disable (except LU series)
- UL, CSA, TÜV, VDE, BABT, CE marked
- Remote sense and current limit
- BUS OK and AC OK (except LU series)
- 40ms ride-through time
- OVP and thermal shutdown
- 1 output; up to 200W
- 1 or 2 outputs; up to 400W
- 1, 2, or 3 outputs; up to 600W

FlatPAC Configuration Chart

Typical Model: VI - R U 0 1 1 - E U U U - ••••

Input: 115/230Vac; Output 1: 5Vdc at 200W
Output 2: 12Vdc at 200W
Output 3: 12Vdc at 200W

	Total Power	Part No.	# of Converters	Dimensions
Single Outputs:	50-200W	VI-LU • - •• ••	1	9.25" x 2.5" x 1.37" (234,8 x 63,5 x 34,8mm)
	200-400W	VI-MU • - •• •••	2	9.25" x 4.9" x 1.37" (234,8 x 124,5 x 34,8mm)
	300-600W	VI-NU • - •• ••••	3	9.25" x 7.3" x 1.37" (234,8 x 185,4 x 34,8mm)
Dual Outputs:	100-400W	VI-PU • • - •• •• ••	2	9.25" x 4.9" x 1.37" (234,8 x 124,5 x 34,8mm)
	150-600W	VI-QU • • - •• ••• ••	3	9.25" x 7.3" x 1.37" (234,8 x 185,4 x 34,8mm)
Triple Outputs:	150-600W	VI-RU • • • - •• •• •• ••	3	9.25" x 7.3" x 1.37" (234,8 x 185,4 x 34,8mm)

Input Characteristics 90-132/180-264Vac U = Autoranging	Output Voltage • Z 2V M 10V K 40V Y 3.3V 1 12V 4 48V O 5V P 13.8V H 52V X 5.2V 2 15V F 72V W 5.5V N 18.5V D 85V V 5.8V 3 24V B 95V T 6.5V L 28V R 7.5V J 36V	Product Grade •• E = 0°C to +85°C Case C = 0°C to +85°C Case I = -30°C to +85°C Case	Output Power/Current ••• V _{out} ≥ 5V V _{out} < 5V Y = 50W Y = 10A X = 75W X = 15A W = 100W W = 20A V = 150W V = 30A U = 200W U = 40A
Output Power ••• V _{out} ≥ 5V V _{out} < 5V W = 100W W = 20A V = 150W V = 30A U = 200W U = 40A S = 300W S = 60A Q = 400W Q = 80A		Output Power/Current ••• V _{out} ≥ 5V V _{out} < 5V S = 300W S = 60A P = 450W P = 90A M = 600W M = 120A	Options ••• BC = BatMod/Conduction Cooled BM = BatMod CC = Conduction Cooled

FlatPAC Specifications

(Typical at 25°C, nominal line and 75% load, unless otherwise specified.)

Input Characteristics	
AC line input	
Autoranging	90-132/180-264Vac
Line frequency	47 to 63Hz (C-grade and E-grade) 47 to 440Hz (I-grade)
Inrush current	
115Vac operation	1 converter: 16A @ peak line; 2 converters: 23A @ peak line; 3 converters: 39A @ peak line
230Vac operation	1 converter: 32A @ peak line; 2 converters: 47A @ peak line; 3 converters: 78A @ peak line
Ride-through time (full load)	
90/180Vac low line	5ms minimum
115/230Vac nominal line	40ms minimum
AC fail warning time	5ms minimum (low line, full load)
AC and BUS OK (2 converter and 3 converter models only)	
Off state	Vce = 70V maximum
On state	Vcesat = 0.4V maximum @ 1mA (1.5mA max.)
Module disable (2 converter and 3 converter models only, optically isolated LED input)	
Continuous forward current	1 mA to 30mA
Forward voltage	1.65V max. at 30mA
Dielectric withstand	
Primary to chassis GND	2,121Vdc
Primary to secondary	4,242Vdc
Secondary to chassis GND	707Vdc

Output Characteristics (applies to each output individually)								
	E-Grade			C-, I-Grade			UNITS	NOTES
	MIN.	TYP.	MAX.	MIN.	TYP.	MAX.		
Setpoint accuracy		1%	2%		0.5%	1%	V _{NOM}	
Load/line regulation			0.5%		0.05%	0.2%	V _{NOM}	LL to HL, 10% to Full Load
Load/line regulation			1%		0.2%	0.5%	V _{NOM}	LL to HL, No Load to full load
Output temperature drift		0.02			0.01	0.02	%/°C	Over rated temperature
Long term drift		0.02			0.02		%/1k hours	
Output ripple								
2V			150mV		60mV	100mV	p-p	20MHz bandwidth
5V			5%		2%	3%	p-p	20MHz bandwidth
10-48V			3%		0.75%	1.5%	p-p	20MHz bandwidth
Output voltage trimming ¹	50%		110%	50%		110%		
Total remote sense compensation	0.5			0.5			Volts	0.25V max. neg. leg
OVP setpoint		125%		115%	125%	135%	V _{NOM}	Recycle power
Current limit	105%		135%	105%		125%	I _{NOM}	Automatic restart
Short circuit current ²	20%		140%	20%		130%	I _{NOM}	

Thermal Characteristics								
Efficiency		78-88%			80-90%			
Shutdown temp. — case	90	95	105	90	95	105	°C	Cool and recycle power to restart
Operating temp. — case			85			85	°C	See Thermal Curves

Mechanical Specifications			
Weight ³	22.4 (652)		Ounces (Grams)

Safety Agency Approvals
UL, CSA, TUV, VDE, IEC 950, CE Marked for low voltage directive, 73/23/EEC

Environmental Characteristics/Product Grade Designators	
Storage temperature	-20°C to +100°C (C-grade and E-grade) -55°C to +100°C (I-grade)
Operating temperature (case)	0°C to +85°C (C-grade and E-grade) -30°C to +85°C (I-grade)

EMI / EMC Characteristics (Performed on selected samples representative of the U Series FlatPac product family.)	
Conducted emissions, LISN	EN 55022 and FCC R&R, Part 15, Subpart B, Class B
Electrostatic discharge	IEC 801-2, 1991, Level 4; ±8kV Contact, ±15kV Air Discharge
RF radiated immunity, E-field	IEC 801-3, 1984; 27MHz to 500MHz, 3 V/M, CW
Electrical fast transients/burst	EN 61000-4-4, Level 2; ±1kV
Surge immunity	EN 61000-4-5, Class 3; ±2kV Line to Ground, ±1kV Line to Line

¹ 10, 12V and 15V outputs, trim range ±10%. Consult factory for wider trim range.

² Output voltages of 5V or less incorporate foldback current limiting, greater than 5V incorporate straight line current limiting.

³ For MU, PU series, multiply value by 2; for NU, QU, RU series, multiply value by 3.

Thermal Curves, 5V Output

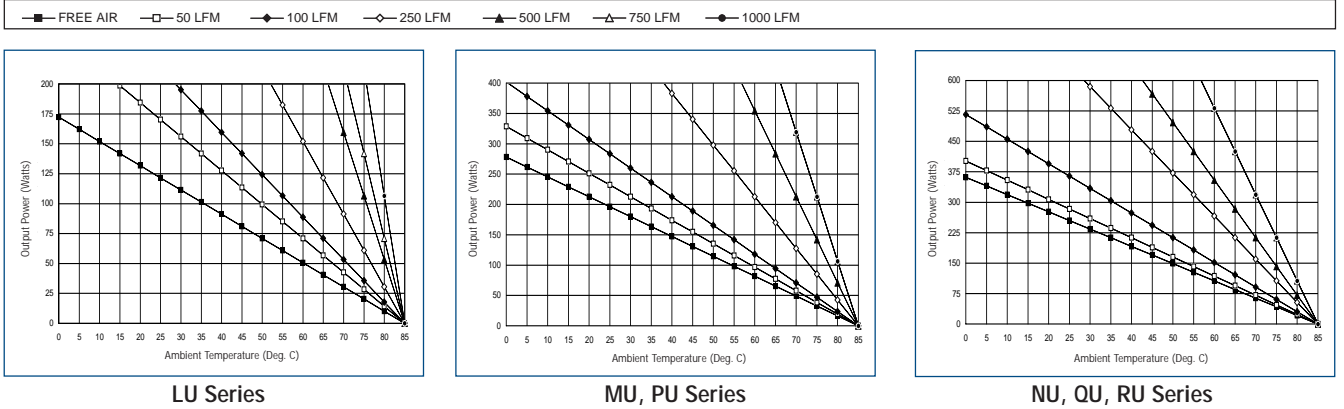

Thermal Curves, 10 to 48V Output

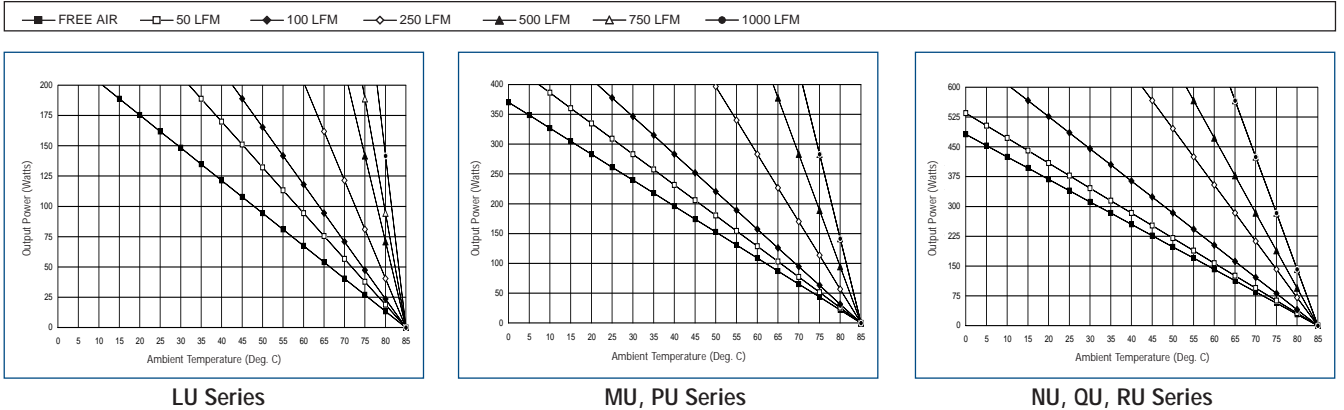

Application Circuits

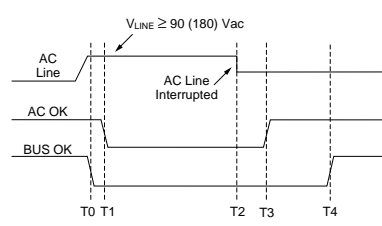
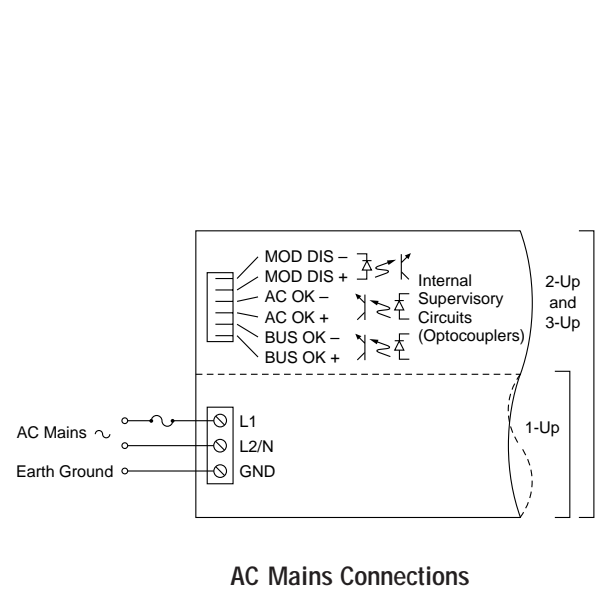

Conditions: Full Load 90 (180) Vac, AC Line

Time Interval	Min	Typ	Max	Units	Notes
T0-T1	0	0.1	1.0	ms	
T2-T3	0	40	-	ms	Ride-through time
T2-T4	5	-	-	ms	Hold-up time
T3-T4	5	-	-	ms	AC fail warning time

Power Up and Power Down Sequencing

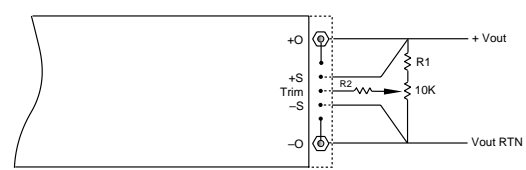

Resistor Values for Trimming Standard Output Voltages

Nom. Output Voltage	5V	12V	15V	24V	28V	48V	Trim Range
R1(kΩ)	0.953	15.8	22.1	41.2	48.7	90.9	+10%, -10%
R2(kΩ)	90	90	90	90	90	90	

Output Trimming

Mechanical Drawings

Inputs

- 1 MOD DIS-
 - 2 MOD DIS+
 - 3 AC OK-
 - 4 AC OK+
 - 5 BUS OK-
 - 6 BUS OK+
 - 7 AC IN L1
 - 8 AC IN L2/N
 - 9 CHASSIS GND
- Input connector, Amp P/N 644488-6; mating connector, MTA-100 IDC Series
- Terminals for #16-12 AWG wire

Outputs

- 10 +OUT (#10-32 Stud)
 - 11 +OUT
 - 12 +SENSE (V_{TRIM}^*)
 - 13 TRIM (I_{TRIM}^*)
 - 14 -SENSE (I_{MON}^*)
 - 15 -OUT
 - 16 -OUT (#10-32 Stud)
- Output connector, Amp P/N 644486-5; mating connector, MTA-100 IDC Series

*On FlatPACs with BatMODs only.

All Models

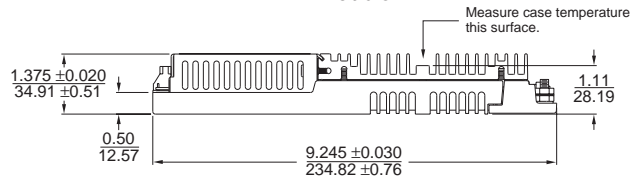

LU Series

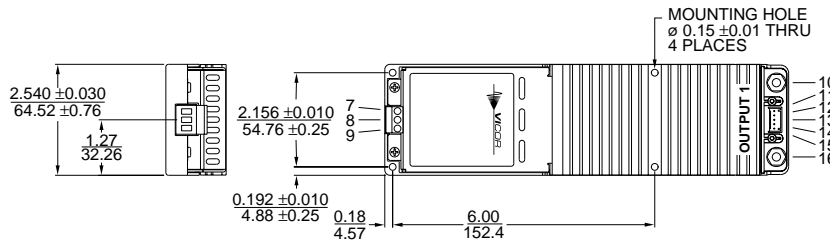

MU, PU Series

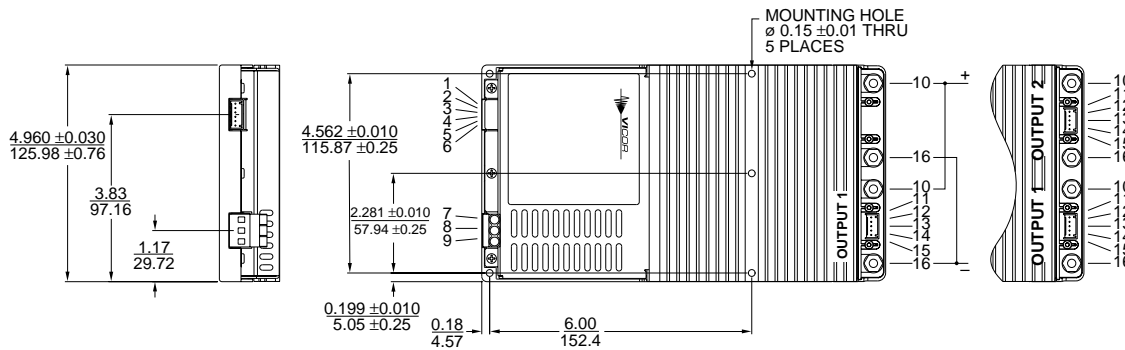

NU, QU, RU Series

