

PRELIMINARY



Data Sheet

QuietPower™

Output Ripple Attenuation SiP

Features

- >20dB PARD attenuation from 50Hz to 500kHz
- Supports point of load regulation
- Peak ripple detector optimizes performance automatically
- Significantly improves load transient response
- Efficiency up to 98%
- User selectable performance optimization
- 3-30Vdc operating range
- 10A rating

Patents Pending



Shown actual size:
1.0 x 1.0 x 0.2 in
25 x 25 x 5 mm

Product Highlights

Picor's QPO-1 output ripple attenuator System-in-a-Package (SiP) provides active filtering to achieve greater than 20 dB attenuation of periodic and random deviation (PARD) over the frequency range of 50Hz to 500kHz.

The QPO-1 operates over a voltage range of 3 to 30Vdc and is compatible with most switching power supplies and converters. The load is regulated by using remote sensing or a reference type trim adjustment feature as is commonly found on most power supplies.

The QPO-1's closed loop architecture greatly improves load transient response while ensuring steady-state precise point of load voltage regulation. The QPO-1 is available in surface mountable Land Grid and Ball Grid Array terminations.

Absolute Maximum Ratings

Exceeding these parameters may result in permanent damage to the product

Parameter	Rating	Unit	Notes
+In to -In	33	Vdc	Continuous
+In to -In	40	Vdc	100ms
Load current	15	A	Continuous
Maximum power dissipation	4	W	
Operating temperature	-20 to +85	°C	Ambient
Package thermal resistance	50	°C/W	Free Air
Package thermal resistance	TBD	°C/W	Optimum heat sinking
Storage temperature	-40 to +125	°C	

Part Numbering

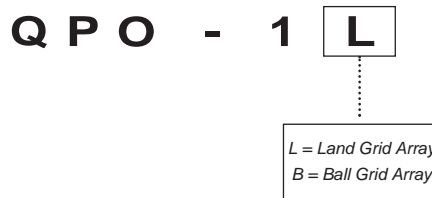

PRELIMINARY

Electrical Characteristics

Electrical characteristics apply over the full operating range of input voltage, output power and PCB substrate temperature, unless otherwise specified. All temperatures refer to the operating temperature at the interface of the PCB surface with proper reflow mounting of QPO-1. The PCB surface must have sufficient area and heat via's to the opposite side to achieve the optimum thermal resistance.

■ QPO-1 SiP SPECIFICATIONS (-20°C to +100°C PCB Substrate temperature)

Parameter	Min	Max	Unit	Notes
Operating current range	0.03	10	A	There is no internal current limiting. The system must be properly fused such that the current does not exceed the absolute maximum rating of 15A. A minimum current of 30mA is needed to maintain regulation.
Operating input voltage	3.0	30	Vdc	Continuous
Transient output response				Step load change rates <1A/μs
@ 2A step		50	mVp-p	V _{HR} =375mV @ 100mA, Input capacitance = 200μF
@ 10A step		50	mVp-p	V _{HR} =375mV @ 100mA, Input capacitance = 1500μF
V _{HR} headroom voltage range ⁽¹⁾	225	525	mV	@ 100mA load with 100mVp-p ripple. See Table 1 for headroom setting R _{HR} resistor values. QPO _{OUT} + V _{HR} must be set below converter over voltage trip.
Output noise		10 5	mVp-p mVrms	Input PARD = 100mVp-p, 50Hz-500kHz
SC output current accuracy ⁽²⁾		±1	%	See Note 2 and Figure 2 for setting R _{SS} value I _{SC} =V _{HR} / R _{SS}
QPO-1 bias current		60	mA	
Power dissipation		4.0	W	QPO _{OUT} = 28V; I _{out} = 10A V _{HR} = 375mV @ 100mA (without slope adjust or peak detection.)

⁽¹⁾ Headroom voltage, peak detection and slope adjustment must be chosen by the user based on attenuation and efficiency requirements. The functional description section explains how to optimize the configuration of the QPO-1 for the voltage source used. The headroom voltage is the difference between the input and the output of the QPO-1 and is set by the selection of resistor R_{HR}. Calculate R_{HR} as shown.

$$R_{HR} = (QPO_{OUT} / V_{HR}) \times 2.5k \text{ (see Table 1 for example values)}$$

⁽²⁾ R_{SS} resistor sets the correction current required to trim the source output up to accommodate the headroom of the QPO-1 when remote sense is not used. This function will accommodate power supplies with positive reference based trim configuration.

$$R_{SS} = R_{IN} \cdot V_{OUT} / V_{RPT} \text{ (If a converter is trimmed down use the resulting } V_{OUT} \text{ voltage in the formula for } R_{SS} \text{)}$$

Where: R_{IN} = input resistance of the SC or Trim pin;
V_{OUT} = source output voltage;
V_{RPT} = SC or Trim pin pre-trimmed reference

QPO-1 Output	R _{HR} Value (ohms)
3.0V	20k
5.0V	33.3k
12.0V	80k
15.0V	100k
24.0V	160k
28.0V	187k

Table 1—R_{HR} computed values for V_{HR} = 375mV @ 100mA.

Application Notes

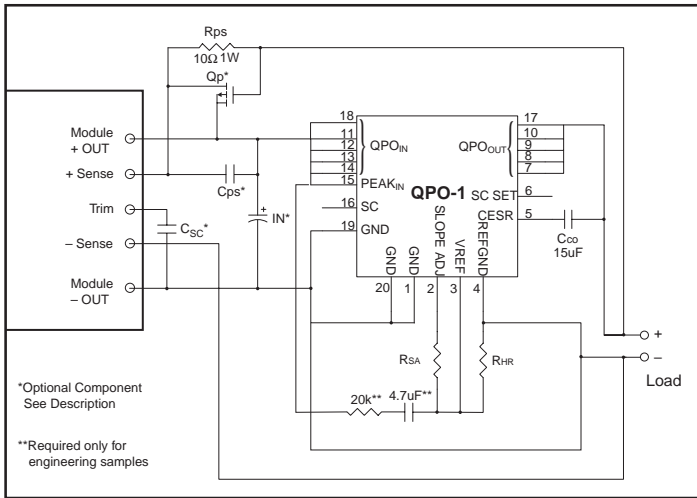

Figure 1—Typical Configuration using Remote Sensing

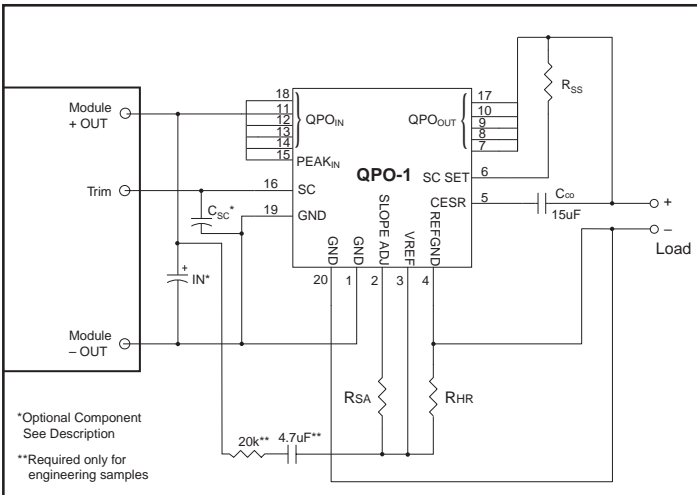

Figure 2—Typical Configuration using Trim Control

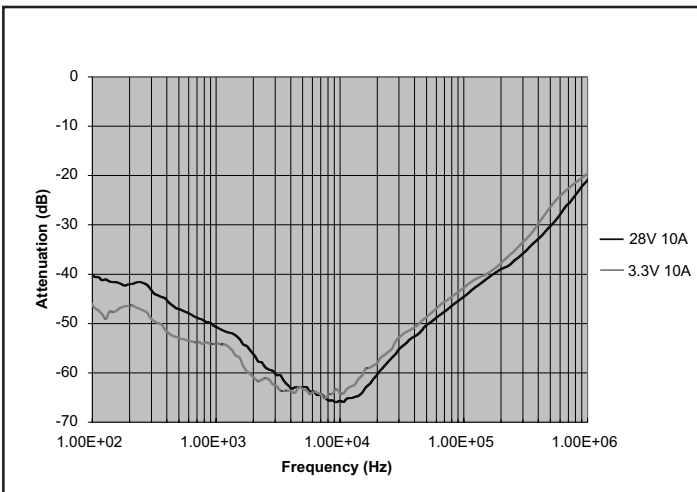

Figure 3—Attenuation vs. Frequency

Functional Description

The QPO-1 is an active power filter that provides attenuation of power supply output PARD. The measured attenuation performance over frequency is shown in Figure 3 at output voltage conditions of 3.3 and 28 Vdc. The user can select and optimize the attenuation versus power dissipation by setting the headroom voltage of the active loop.

The conditions in Figure 3 were measured with a low current headroom setting of 375mV with approximately 100mV peak-to-peak ripple voltage on the input to the QPO-1. The remote sense circuit configuration was used as shown in Figure 1 with the peak detector function enabled. Some power supplies need to sense the output ripple for proper operation. Cps couples the unfiltered ripple back to the sense input while Rps provides the DC feedback to the power supply from the load.

Typical improvement in output noise and transient performance with a 3.3V converter is shown in Figure 4. This measured data demonstrates the reduction in noise and ripple at the output of the QPO-1 versus the source output as well as the transient capability stepping from 1 to 10A load current - the maximum current rating. This particular converter has sufficient output capacitance and response time to load changes such that no additional capacitance, C_{IN}, is needed on the input of the QPO-1 to reach a 10A level and still maintain the output within ±50mV.

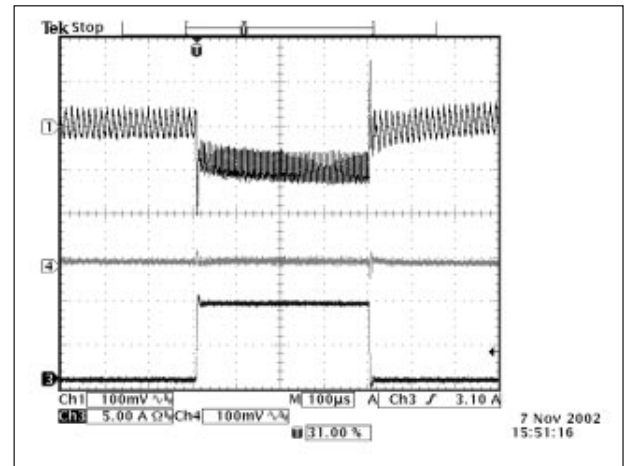

Figure 4 - Transient Response using a Vicor 3.3V Half Brick Converter

Ch1: QPO_{IN}
 Ch4: QPO_{OUT}
 Ch3: Load Current – 10A peak, pulse width = 400μS
 Load Current Static = 1A
 Load Current Transient = 9A
 Headroom Voltage @ 100mA = 400mV

PRELIMINARY

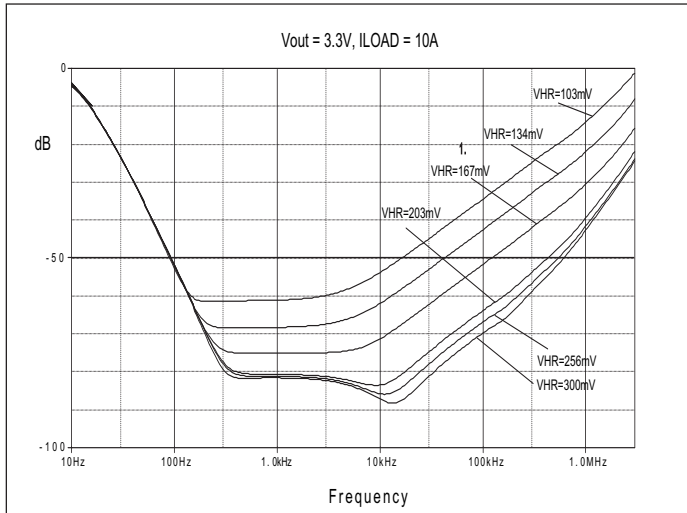

Figure 5 – Attenuation vs Frequency @ 3.3 volts

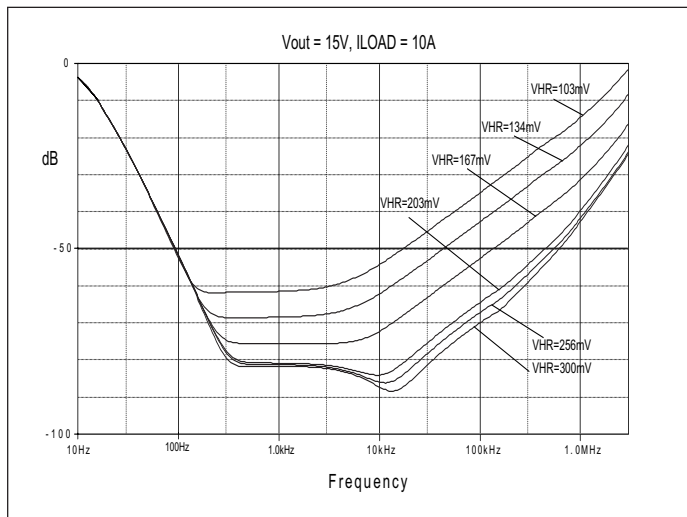

Figure 6 – Attenuation vs frequency @ 15 volts

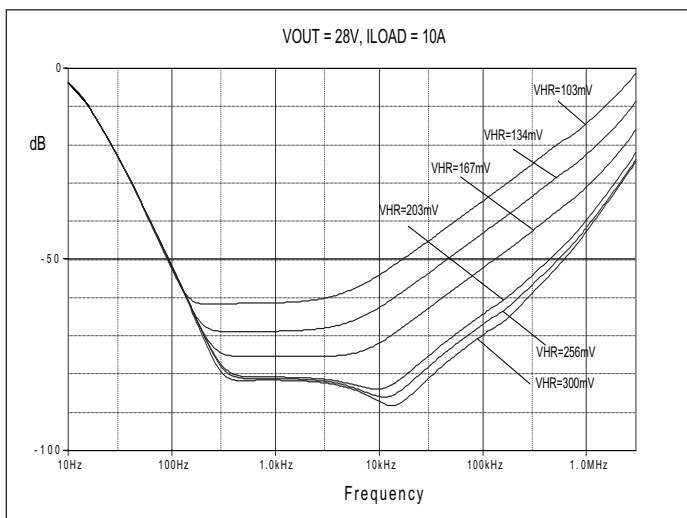

Figure 7 – Attenuation vs Frequency @ 28 volts

The product can be used with voltage sources from 3 to 30Vdc by using either the remote sense or the voltage trim feature. The two different circuit schematics are shown in Figures 1 and 2. For either configuration, the source output will increase to accommodate the headroom setting of the QPO-1 filter to maintain the load voltage at the required level.

The user can optimize performance by setting the low current (100mA) headroom operating point per Table 1 or by using the formulas in Notes 1 and 2 above the table. The user must be aware of the sources over-voltage set-point and not create a headroom voltage that will cause a shutdown condition. For this reason it is recommended that the QPO-1 be used with power supplies running at their factory preset voltages or in a trimmed down configuration.

In low voltage applications (<12V), it may be required to use the C_{SC} capacitor. This creates a soft starting of the source preventing the output from tripping the over voltage function while the QPO-1 output line comes up to the set-point. The C_{SC} value will be converter dependent but is typically around 5 to 22 μ F. Remote sensing may also require Q_p for start up, use a logic level low voltage PFET such as IRLML6401 or equivalent.

The spice simulation Figures 5, 6, and 7 demonstrate the effects of headroom versus attenuation for 3.3, 15, and 28V respectively. The attenuation and power dissipation will decrease with headroom setting so a trade-off can be selected for efficiency versus attenuation. The transient performance is proportional to the headroom setting, power source response time and the capacitance present at the input to the QPO-1. The capacitance may be within the power supply that is used or supplemented by external capacitance. Consideration of the source's sensitivity to additional output capacitance and stability must be understood before additional capacitance is added for enhancement of transient performance.

The QPO-1 has two additional features that the user can select to further optimize performance. The first is a headroom slope adjustment that reduces the headroom voltage drop with increasing load current. The second is a peak detector function that increases the headroom voltage by the peak of the ripple voltage.

Headroom Slope Adjustment

This can be used to allow for more headroom and improved transient response at lower loads and also to approximate constant power dissipation over the load range. The slope of this curve is set by the slope adjust resistor R_{SA} . See below for setting the R_{SA} value. The headroom in Figures 5, 6, and 7 are at 10A and have been reduced by 150mV from the low current headroom setting with the slope function using an R_{SA} value of 8.2k Ω . This feature is useful to improve efficiency when used with converters that have decreasing ripple with increasing load current such as is typical with Vicor products.

PRELIMINARY

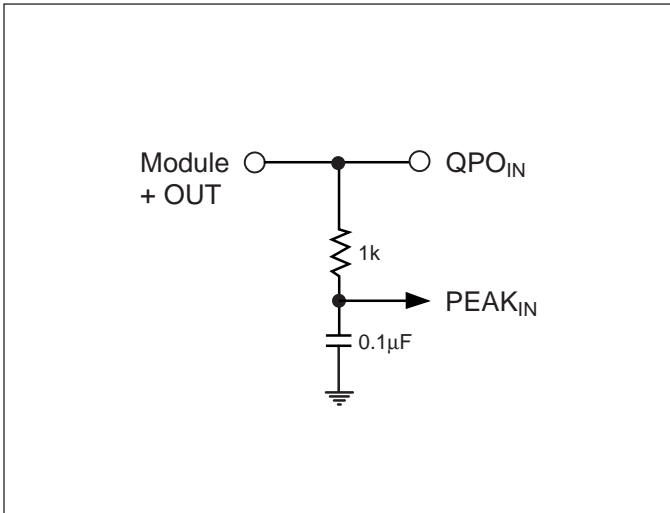

Figure 8 – Peak detector Disable Circuit

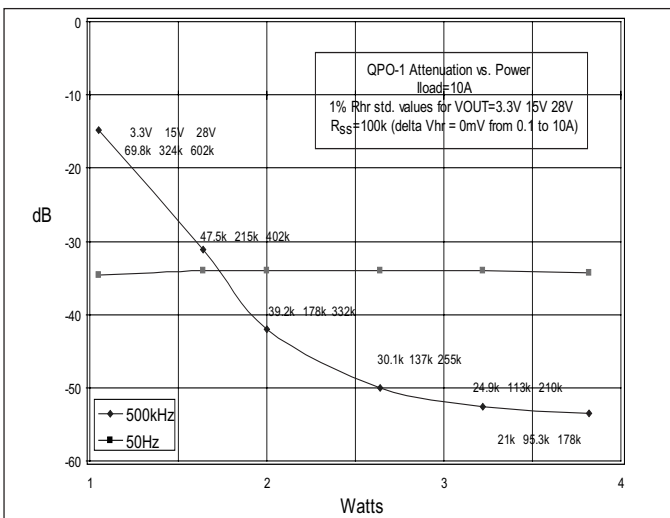

Figure 9 – Power vs Attenuation without slope

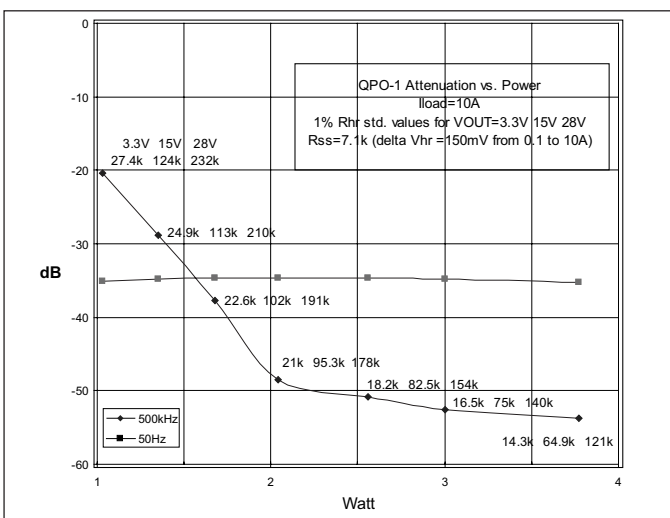

Figure 10 – Power vs Attenuation with slope adjust

The slope adjust feature can be set to zero providing relative constant headroom versus load using an R_{SA} of $100k\Omega$. The user can optimize performance based on the expected variation in load current and the desired power dissipation range. The formula below should be used to calculate the R_{SA} value for the desired headroom versus current slope. If the peak detector is enabled, the peak of the ripple will be added back to the headroom at a given load condition.

$$R_{SA} = ((\Delta I * 0.05) / \Delta V) * 2500$$

Example: For a 5A maximum load and a 150mV reduction in headroom.

$$R_{SA} = ((5A * 0.05 / 0.15V) * 2500\Omega) = 4.167k\Omega$$

Peak Detector Function

This feature dynamically adds to the headroom voltage to accommodate converter ripple variation. This feature can be enabled by connecting the $PEAK_{IN}$ pin to the QPO_{IN} pin and disabled by putting a small RC filter at the $PEAK_{IN}$ pin as shown in Figure 8.

The active loop performance has been optimized for 45 degrees of phase margin over the expected load range. C_{CO} shown in Figs 1 and 2 must be a low ESR ceramic capacitor. Loading the QPO-1 directly with low ESR ceramic capacitance will affect the phase margin and is not recommended. The distributed load capacitance and inductance of the load path will vary depending on the application. The effects of a distributed load impedance on phase margin when very low ESR load capacitance is present will typically be mitigated by the distributed inductance of the load path. The transient load response in Figure 4 was measured with approximately 10nH of distributed inductance between QPO-1 output and the load board which had a 15µF low ESR ceramic capacitor across the static load resistance.

The following is a summary of the optional configurations that a user can select for the QPO-1.

- No slope adjust, no peak detect: fixed headroom over ripple amplitude and current.
- Same as above, but with peak detect enabled: peak of ripple amplitude is added to the headroom voltage optimizing headroom with varying ripple amplitude.
- No peak detection with slope adjust: to improve transient load range and efficiency trading off attenuation at high current.
- Using both peak detection and slope adjust: to accommodate ripple amplitude variation with increased transient capability and efficiency.

PRELIMINARY

Figures 11, 12, and 13 show the headroom performance at 3.3, 15, and 28 volts respectively with an $R_{SA} = 8.2k$ for the three plots.

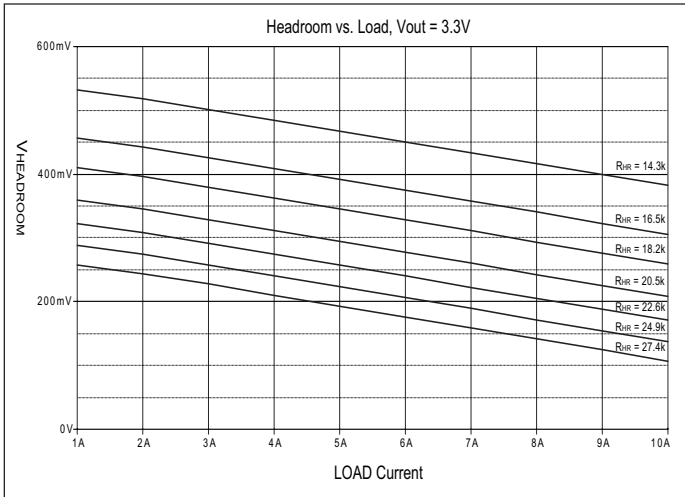

Figure 11 – Headroom vs Current @ 3.3V with 150mV of slope adjust from 0.1A to 10A

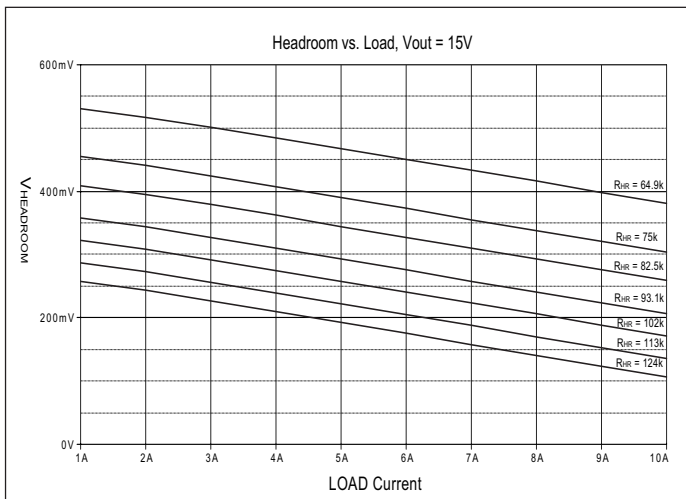

Figure 12 – Headroom vs Current @ 15V with 150mV of slope adjust from 0.1A to 10A

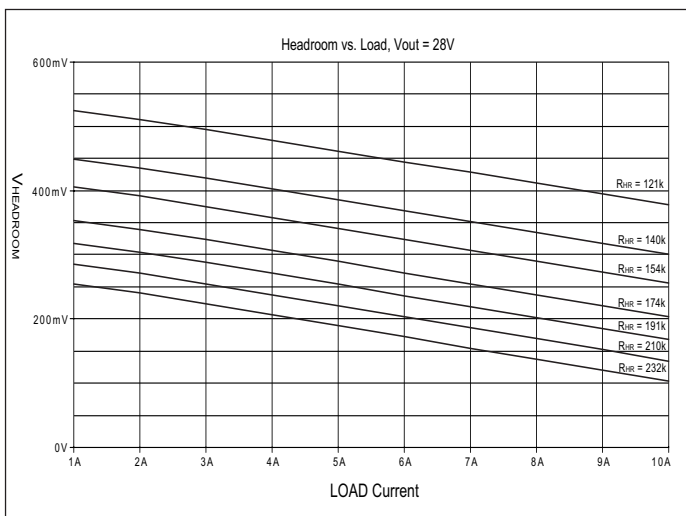
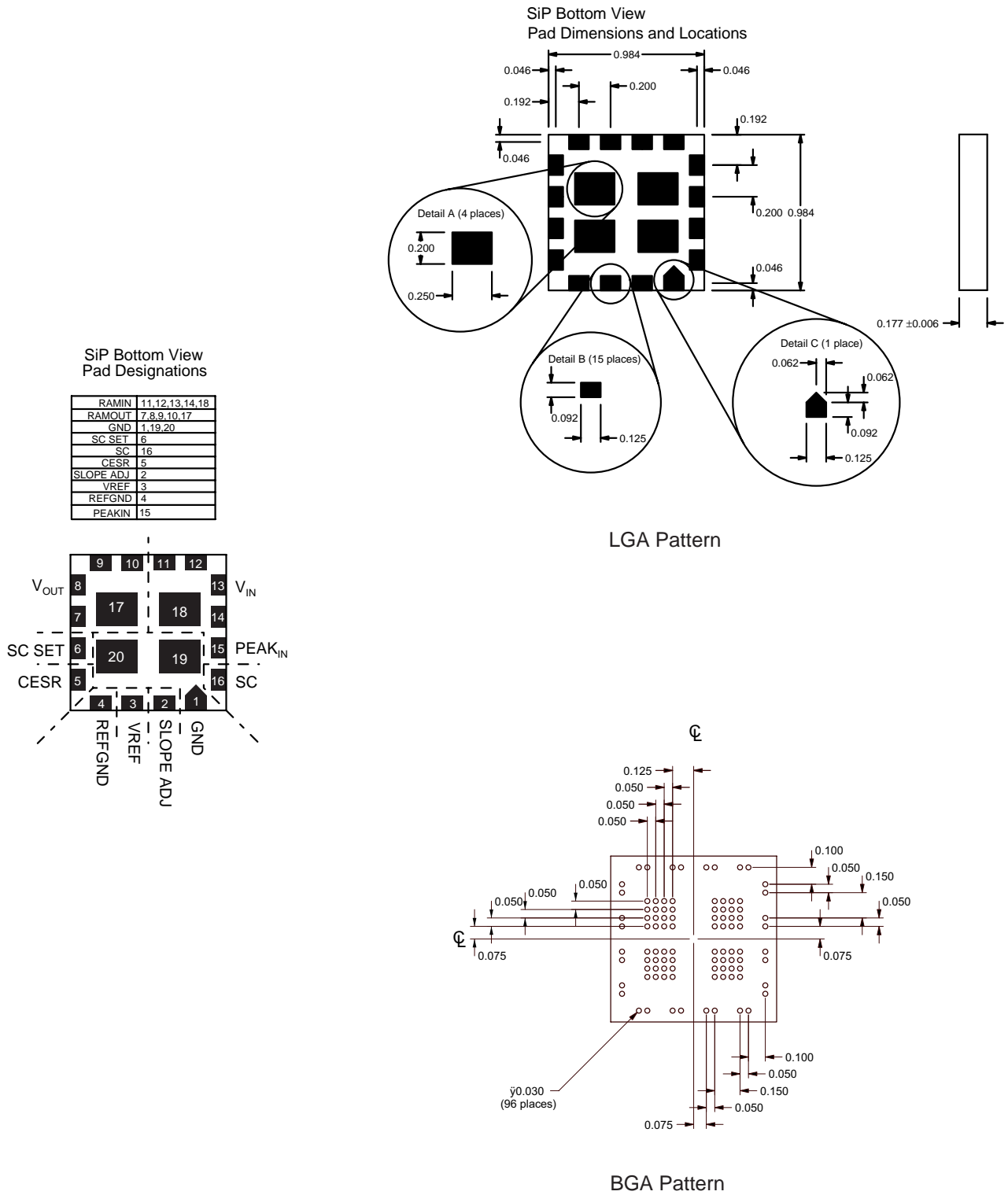

Figure 13 – Headroom vs Current @ 28V with 150mV of slope adjust from 0.1A to 10A

PRELIMINARY

Mechanical Drawings



Vicor's comprehensive line of power solutions includes modular, high-density AC-DC & DC-DC modules and accessory components, fully configurable AC-DC & DC-DC power supplies, and complete custom power systems.

Information furnished by Vicor is believed to be accurate and reliable. However, no responsibility is assumed by Vicor for its use. No license is granted by implication or otherwise under any patent or patent rights of Vicor. Vicor components are not designed to be used in applications, such as life support systems, wherein a failure or malfunction could result in injury or death. All sales are subject to Vicor's Terms and Conditions of Sale, which are available upon request.

Specifications are subject to change without notice.



*Component Solutions
for Your Power System*

Vicor Corporation
25 Frontage Road
Andover, MA, USA 01810
Tel: 800-735-6200
Fax: 978-475-6715

Email

Vicor Express: vicorexp@vicr.com
Technical Support: apps@vicr.com