



Data Sheet

VI-AIM

Universal AC Input Front End Module

Features

- Universal Input: 85 to 264Vac
- Output Power: 250W
- Operating Temperature: 100°C
- Efficiency: 97%
- Integral EMI Filtering
- Input Transient Protection
- Inrush Limiting
- CE Marked



Shown actual size:
2.28 x 2.4 x 0.5 in
57,9 x 61,0 x 12,7 mm

VI-AIM Input Voltage	Compatible DC-DC Converter
85-132Vac	VI-X5X
180-264Vac	VI-X6X
85-264Vac	VI-X7X

VI-AIM Specifications

(typical at $T_{BP} = 25^{\circ}\text{C}$, nominal line, 75% load unless otherwise specified)

Product Highlights

The AIM (Alternating Input Module) is an AC front-end module which interfaces directly with worldwide AC mains. The AIM provides line rectification, EMI/RFI filtering, transient protection and inrush limiting in a half brick package measuring 2.28" x 2.4" x 0.5".

The AIM is used in conjunction with Vicor VI-200 or VI-J00 DC-DC converters to realize a universal AC input, high density, low profile switching power supply with outputs from 1-95Vdc and a total power rating up to 200W. An external capacitor is used to satisfy system hold up requirements. Internal EMI filtering meets EN55022 and FCC part 15, class A emissions limits.

VI-AIM Selection Chart

PC Mount	
VI-AIM-E1	VI-AIM-I1
VI-AIM-C1	VI-AIM-M1
Mega Module packaging option	
VI-LAIM-E1	VI-LAIM-I1
VI-LAIM-C1	VI-LAIM-M1

Parameter	Specifications	Remarks
AC Line Input	85Vac to 264Vac* 47 Hz to 440 Hz	No strapping; no damage below low line
Output Voltage	120-373 Vdc	Peak of AC line
Efficiency	97%	
Output Power	250W	Delivered to converter(s)
Holdup Time	Application specific	A function of external capacitance and power
Maximum Value of Holdup Capacitance	1200 μF	
Conducted EMI/RFI	VDE 0871/FCC Part 15, Class A EN 55022, Class A	With compatible DC-DC converter modules. External 0.47 μF capacitor required.
Inrush Current	<40A at Peak Line (264 Vrms)	
Transient Surge Withstand		
Common Mode	1.2/50 μs , 2 kV Pulse, 2 Joules 0 to 360 Degree Phase Angle	EN61000-4-5 IEC 801-5
Normal Mode	1.2/50 μs , 1 kV Pulse, 2 Joules 0 to 360 Degree Phase Angle	With external MOV
Dielectric Withstand		
Input to Output	None	Provided by DC-DC converter
Input/Output to Baseplate	1,500 Vrms	
Thermal Resistance	0.4°C/Watt	Baseplate-to-sink
Safety Approvals	UL 1950, CSA 22.2-950, EN 60950	
Size	2.28" x 2.4" x 0.5" (57,9 x 61,0 x 12,7) packages available	Mega Module, SlimMOD and FinMOD
Weight	3.0 Ounces (85 Grams)	

*Dependent upon input range of compatible DC-DC converter.

Product Grade Specifications

Parameter	E-Grade	C-Grade	I-Grade	M-Grade
Storage Temperature	-20°C to +105°C	-40°C to +105°C	-55°C to +105°C	-65°C to +105°C
Operating Temperature (Baseplate)	-10°C to +100°C	-25°C to +100°C	-40°C to +100°C	-55°C to +100°C

VI-AIM Connection Diagram, Typical Application

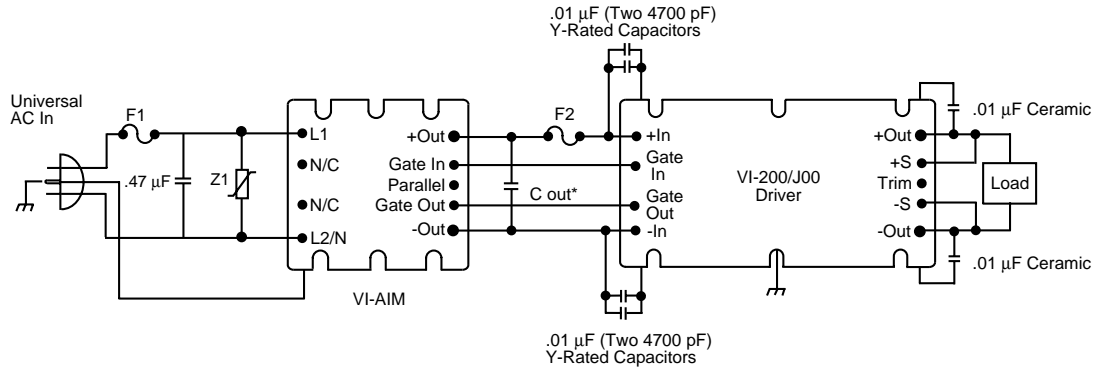

* See Vicor's Applications Manual, page 12-2, Selecting Capacitors for AIM Modules.

Z1: MOV P/N 03040

Fuse 1: 6.3A/250V (IEC 5X20 mm) Buss GDB-6.3 or 7A/250V (3AG 1/4" x 1 1/4") Littlefuse 314-007

Fuse 2: For VI-X7X-XX — Buss PC-Tron 2.5A (250V)
 For VI-X6X-XX — Buss PC-Tron 3A (250V)
 For VI-X5X-XX — Buss PC-Tron 5A

VI-AIM Block Diagram

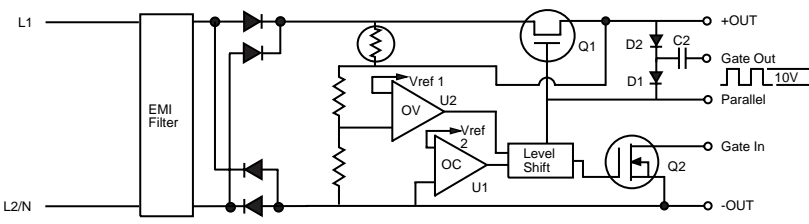

Mechanical Diagram

