



## P-Channel Enhancement-Mode MOSFET Transistors

PRODUCT SUMMARY				
Part Number	$V_{(BR)DSS}$ Min (V)	$r_{DS(on)}$ Max ( $\Omega$ )	$V_{GS(th)}$ (V)	$I_D$ (A)
VP0300B	-30	2.5 @ $V_{GS} = -12$ V	-2 to -4.5	-1.25
VP0300L		2.5 @ $V_{GS} = -12$ V	-2 to -4.5	-0.32
VP0300LS		2.5 @ $V_{GS} = -12$ V	-2 to -4.5	-0.5
VQ2001J		2 @ $V_{GS} = -12$ V	-2 to -4.5	-0.6
VQ2001P		2 @ $V_{GS} = -12$ V	-2 to -4.5	-0.6

### FEATURES

- High-Side Switching
- Low On-Resistance: 1.5  $\Omega$
- Moderate Threshold: -3.1 V
- Fast Switching Speed: 17 ns
- Low Input Capacitance: 60 pF

### BENEFITS

- Ease in Driving Switches
- Low Offset (Error) Voltage
- Low-Voltage Operation
- High-Speed Switching
- Easily Driven Without Buffer

### APPLICATIONS

- Drivers: Relays, Solenoids, Lamps, Hammers, Displays, Memories, Transistors, etc.
- Battery Operated Systems
- Power Supply, Converter Circuits
- Motor Control

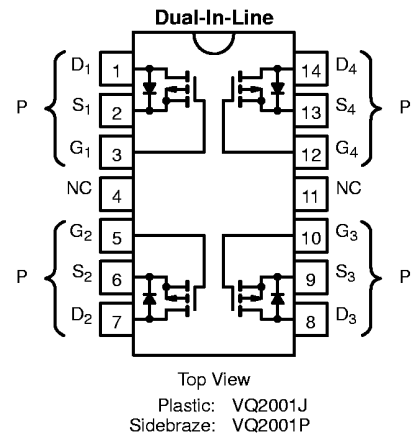
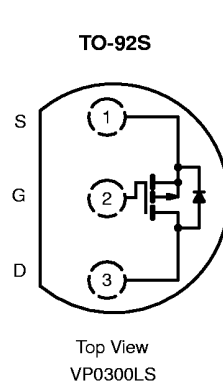
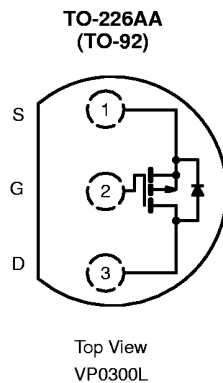
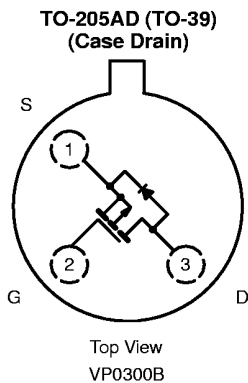

### ABSOLUTE MAXIMUM RATINGS ( $T_A = 25^\circ\text{C}$ UNLESS OTHERWISE NOTED)

Parameter	Symbol	VP0300B	VP0300L	VP0300LS	VQ2001J/P		Unit	
					Single	Total Quad		
Drain-Source Voltage	$V_{DS}$	-30	-30	-30	-30	-30	V	
Gate-Source Voltage	$V_{GS}$	$\pm 20$	$\pm 20$	$\pm 20$	$\pm 20$	$\pm 20$	V	
Continuous Drain Current ( $T_J = 150^\circ\text{C}$ )	$T_A = 25^\circ\text{C}$	$I_D$	-1.25 <sup>b</sup>	-0.32	-0.5	-0.6	-0.6	A
	$T_A = 100^\circ\text{C}$	$I_D$	-0.79 <sup>b</sup>	-0.2	-0.32	-0.37	-0.37	
Pulsed Drain Current <sup>a</sup>	$I_{DM}$	-3	-2.4	-3	-2	-2	A	
Power Dissipation	$T_A = 25^\circ\text{C}$	$P_D$	6.25 <sup>b</sup>	0.8	0.9	1.3	2	W
	$T_A = 100^\circ\text{C}$	$P_D$	2.5 <sup>b</sup>	0.32	0.4	0.52	0.8	
Maximum Junction-to-Ambient	$R_{thJA}$	20 <sup>b</sup>	156	139	96	62.5	$^\circ\text{C/W}$	
Operating Junction and Storage Temperature Range	$T_J, T_{stg}$	-55 to 150						$^\circ\text{C}$

Notes

- a. Pulse width limited by maximum junction temperature.
- b. Power dissipation and continuous drain current at  $T_C = 25^\circ\text{C}$ ;  $R_{thJC} = 20^\circ\text{C/W}$ .

Applications information may also be obtained via FaxBack, request document #70611.

# VP0300B/L/LS, VQ2001J/P



Vishay Siliconix

SPECIFICATIONS (T <sub>A</sub> = 25°C UNLESS OTHERWISE NOTED)								
Parameter	Symbol	Test Conditions	Typ <sup>a</sup>	Limits				Unit
				VP0300B/L/LS		VQ2001J/P		
				Min	Max	Min	Max	
<b>Static</b>								
Drain-Source Breakdown Voltage	V <sub>(BR)DSS</sub>	V <sub>GS</sub> = 0 V, I <sub>D</sub> = -10 μA	-55	-30		-30		V
Gate-Threshold Voltage	V <sub>GS(th)</sub>	V <sub>DS</sub> = V <sub>GS</sub> , I <sub>D</sub> = -1 mA	-3.1	-2	-4.5	-2	-4.5	
Gate-Body Leakage	I <sub>GSS</sub>	V <sub>DS</sub> = 0 V, V <sub>GS</sub> = ±16 V					±100	nA
		T <sub>J</sub> = 125°C					±500	
		V <sub>DS</sub> = 0 V, V <sub>GS</sub> = ±20 V			±100			
Zero Gate Voltage Drain Current	I <sub>DSS</sub>	V <sub>DS</sub> = -24 V, V <sub>GS</sub> = 0 V			-10			μA
		T <sub>J</sub> = 125°C			-500		-500	
		V <sub>DS</sub> = -30 V, V <sub>GS</sub> = 0 V					-10	
On-State Drain Current <sup>b</sup>	I <sub>D(on)</sub>	V <sub>DS</sub> = -10 V, V <sub>GS</sub> = -12 V	-2.8	-1.5		-1.5		A
Drain-Source On-Resistance <sup>b</sup>	r <sub>DS(on)</sub>	V <sub>GS</sub> = -12 V, I <sub>D</sub> = -1 A	1.5		2.5		2	Ω
		T <sub>J</sub> = 125°C	2.6		3.6		3.6	
Forward Transconductance <sup>b</sup>	g <sub>fs</sub>	V <sub>DS</sub> = -10 V, I <sub>D</sub> = -0.5 A	370	200		200		mS
Common Source Output Conductance <sup>b</sup>	g <sub>os</sub>	V <sub>DS</sub> = -7.5 V, I <sub>D</sub> = -0.05 A	0.25					
<b>Dynamic</b>								
Input Capacitance	C <sub>iss</sub>	V <sub>DS</sub> = -15 V, V <sub>GS</sub> = 0 V f = 1 MHz	60		150		150	pF
Output Capacitance	C <sub>oss</sub>		40		100		100	
Reverse Transfer Capacitance	C <sub>rss</sub>		10		60		60	
<b>Switching<sup>c</sup></b>								
Turn-On Time	t <sub>ON</sub>	V <sub>DD</sub> = -25 V, R <sub>L</sub> = 23 Ω I <sub>D</sub> ≅ -1 A, V <sub>GEN</sub> = -10 V R <sub>G</sub> = 25 Ω	19		30			ns
Turn-Off Time	t <sub>OFF</sub>		17		30			
Turn-On Time	t <sub>ON</sub>	V <sub>DD</sub> = -15 V, R <sub>L</sub> = 23 Ω I <sub>D</sub> ≅ -0.6 A, V <sub>GEN</sub> = -10 V R <sub>G</sub> = 25 Ω	19				30	
Turn-Off Time	t <sub>OFF</sub>		16				30	

**Notes**

- a. For DESIGN AID ONLY, not subject to production testing.
- b. Pulse test: PW ≤ 300 μs duty cycle ≤ 2%.
- c. Switching time is essentially independent of operating temperature.

VPEA03



**TYPICAL CHARACTERISTICS (25°C UNLESS NOTED)**

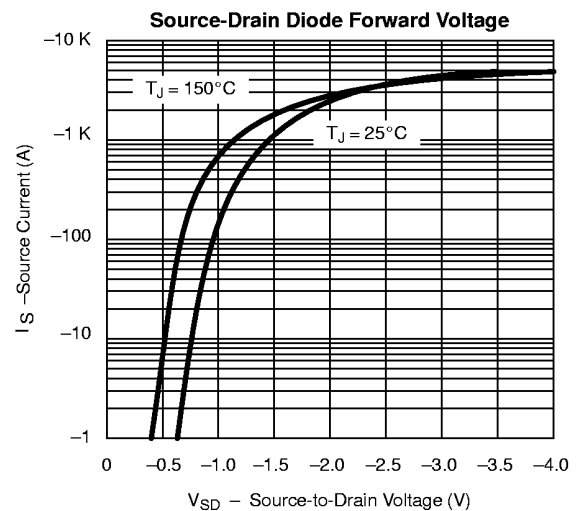
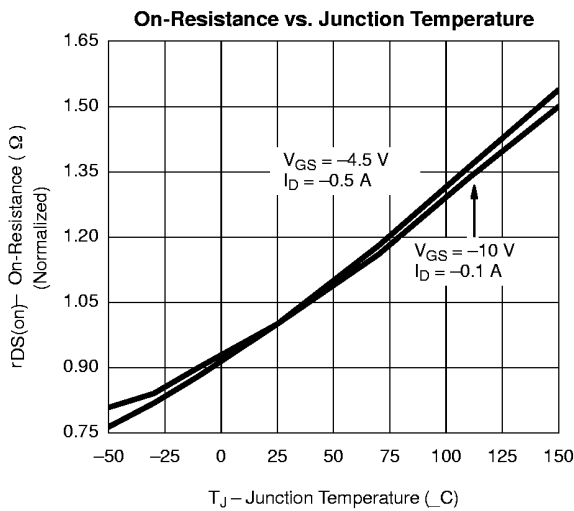
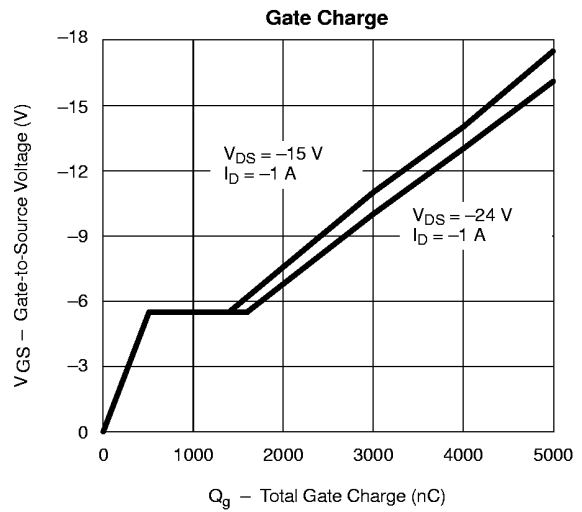
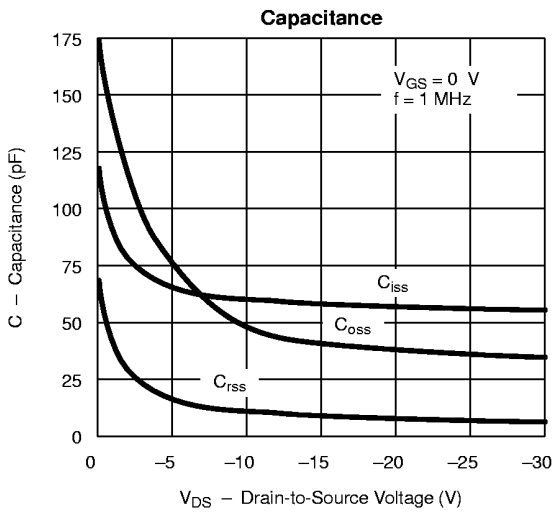
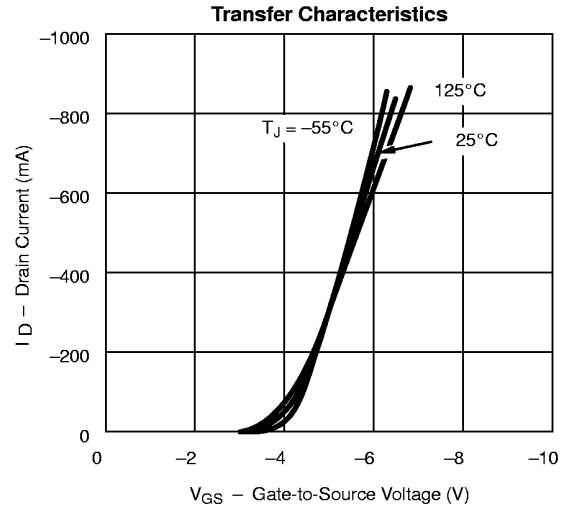
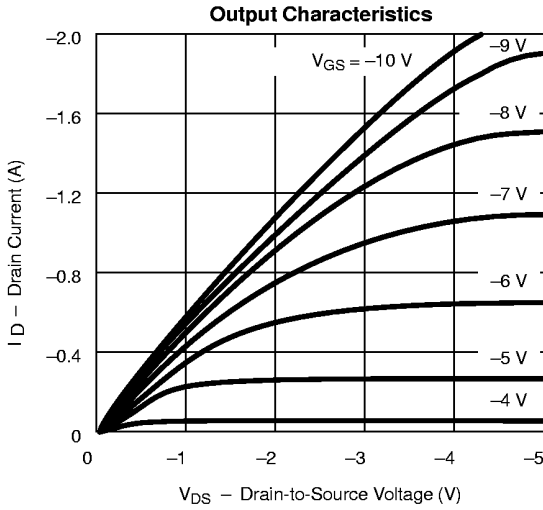



**TYPICAL CHARACTERISTICS (25°C UNLESS NOTED)**

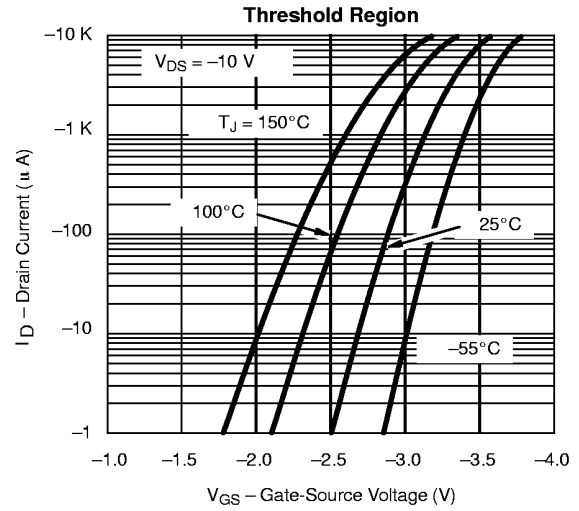
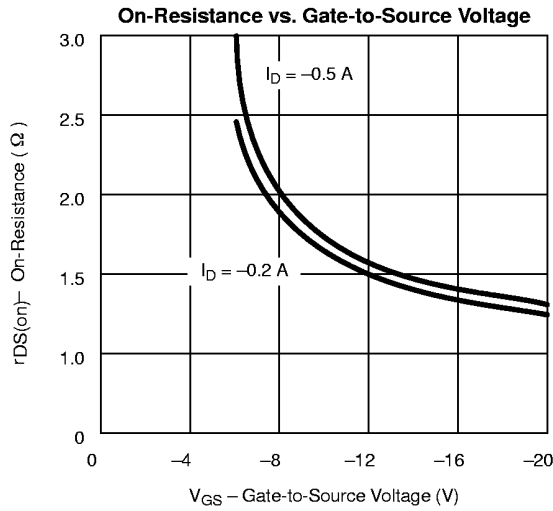

**THERMAL RATINGS**

