

Preliminary Data Sheet

VSC7926

SDH/SONET 2.5Gb/s Laser Diode Driver

Features

- Rise Times of Less Than 100ps
- High-Speed Operation
(Up to 2.5Gb/s NRZ Data)
- Differential Inputs
- Single Supply
- Direct Access to Modulation and Bias FETs
- Data Density Monitors
- On-Chip Reclocking Register

General Description

The VSC7926 is a single 5V supply, 2.5Gb/s laser diode driver with direct access to the laser modulation and bias FETs. Laser bias and modulation currents are set by external components allowing precision monitoring and setting of the current levels. Data density outputs are provided to allow the user to adjust the laser bias in high unbalanced data applications. Clock and data inputs are differentially terminated to 50Ω.

Applications

- SDH/SONET @ 622Mb/s, 1.244Gb/s, 2.488Gb/s
- Full Speed Fibre Channel (1.062Gb/s)

VSC7926 Block Diagram

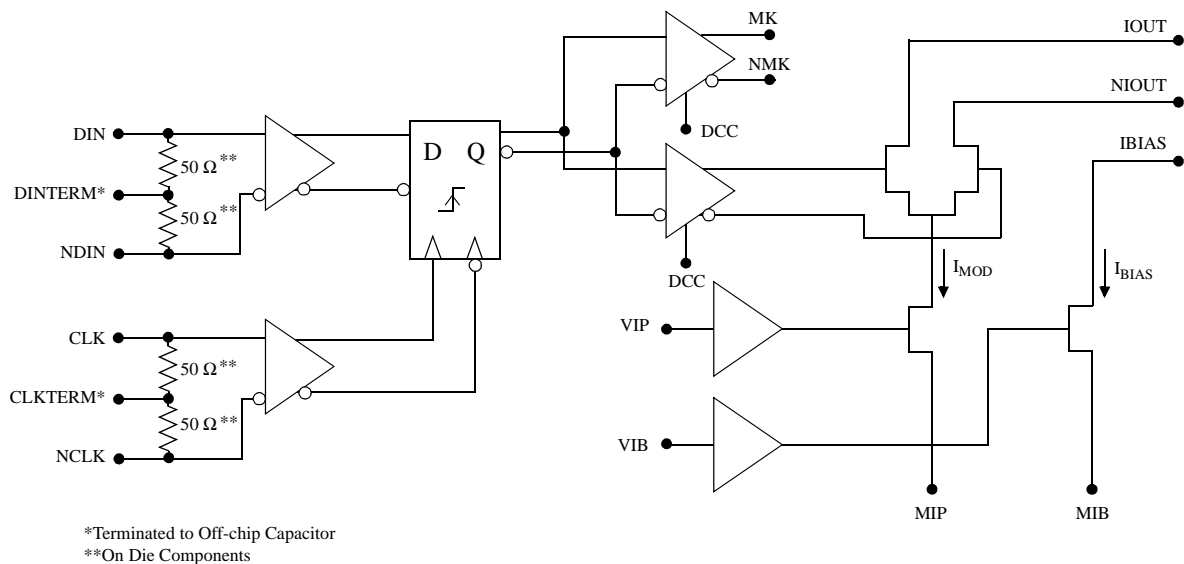

Table 1: Signal Pin Reference

<i>Signal</i>	<i>Type</i>	<i>Level</i>	<i># Pins</i>	<i>Description</i>
DIN, NDIN	In		2	Data Input and Data Reference
DINTERM	Ref	DC	1	Data Termination
CLKTERM	Ref	DC	1	Clock Termination
MK, NMK	Out	ECL	2	Data Density Differential Outputs
NIOUT	Out		1	Laser Modulation Current Output (Complementary)
IOUT	Out		1	Laser Modulation Current Output (To Laser Cathode)
VSS	Pwr	Pwr	3	Negative Voltage Rail
GND	Pwr	Pwr	5	Positive Voltage Rail
VIP	In	DC	1	Modulation Gate Node
MIP	In	DC	1	Modulation Source Node
VIB	In	DC	1	Bias Gate Node
MIB	In	DC	1	Bias Source Node
IBIAS	Out	DC	1	Laser Bias Output (To Laser Cathode)
CLK, NCLK	In		2	Clock Input and Clock Reference
DCC	In	DC	1	Duty Cycle Control, Leave Floating
Total Pins			24	

Table 2: Absolute Maximum Ratings

<i>Symbol</i>	<i>Rating</i>	<i>Limit</i>
V_{SS}	Negative Power Supply Voltage	V_{CC} to -6.0V
T_j	Maximum Junction Temperature	-55°C to +125°C
T_{stg}	Storage Temperature	-65°C to +150°C

Table 3: High Speed Inputs and ECL Outputs

<i>Symbol</i>	<i>Parameter</i>	<i>Min</i>	<i>Max</i>	<i>Units</i>	<i>Conditions</i>
V_{IN}	Differential Input Voltage Swing	500	1000	mV	
V_{CM}	Differential Input Common Mode Range	-2.3	-1.3	V	$V_{SS} = -5.2V$
V_{OH}	ECL Output High Voltage	-1200		mV	50Ω to -2.0V
V_{OL}	ECL Output Low Voltage		-1600	mV	50Ω to -2.0V

Preliminary Data Sheet

VSC7926

SDH/SONET 2.5Gb/s Laser Diode Driver

Table 4: Recommended Operating Conditions

Symbol	Parameter	Min	Typ	Max	Units	Conditions
GND	Positive Voltage Rail	-	0	-	V	
VSS	Negative Voltage Rail	-5.5	-5.2	-4.9	V	
T _{c1}	Operational Temperature ⁽¹⁾	-40	-	85 ⁽²⁾	°C	Power dissipation = 1.25W
T _J	Junction Temperature	-	-	125	°C	

NOTES: (1) Lower limit of specification is ambient temperature and upper limit is case temperature. (2) See "Calculation of the Maximum Case Temperature" section in this data sheet for detailed maximum temperature calculations.

Table 5: Power Dissipation

Symbol	Parameter	Min	Typ	Max	Units	Conditions
I _{VSS}	Power Supply Current (VSS)	-	-	220	mA	V _{SS} = -5.5, I _{MOD} = I _{BIAS} = 0mA
P _D	Total Power Dissipation	-	-	1210	mW	V _{SS} = -5.5, I _{MOD} = I _{BIAS} = 0mA, R _{LOAD} = 25Ω to GND
P _{DMAX}	Maximum Power Dissipation	-	-	1815	mW	V _{SS} = -5.5, I _{MOD} = 60mA, I _{BIAS} = 50mA, I _{OUT} = 0V

Table 6: Laser Driver DC Electrical Specifications

Symbol	Parameter	Min	Typ	Max	Units	Conditions
I _{BIAS}	Programmable Laser Bias Current	2	-	50	mA	
I _{MOD}	Programmable Modulation Current	2	-	60	mA	
V _{IB}	Laser Bias Control Voltage	-	-	V _{SS} + 2.1	V	I _{BIAS} = 50mA
V _{IP}	Laser Modulation Control Voltage	-	-	V _{SS} + 2.1	V	I _{MOD} = 60mA
V _{OCM}	Output Voltage Compliance	GND -2.5V	-	-	V	V _{SS} = -5.2V

Table 7: Laser Driver AC Electrical Specifications

Symbol	Parameter	Min	Typ	Max	Units	Conditions
t _R t _F	Output Rise and Fall Times	-	-	100	ps	25Ω load, 20%-80%, 15mA < I _{MOD} < 60 mA, I _{BIAS} = 40mA
t _{SU}	Setup Data to Clock Setup Time	-	50	-	ps	
t _H	Hold Time	-	50	-	ps	

Table 8: Package Thermal Specifications

Symbol	Parameter	Min	Typ	Max	Units	Conditions
θ _{JCC}	Thermal Resistance from Junction-to-Case	-	25	-	°C/W	Ceramic Package

Calculation of the Maximum Case Temperature

The VSC7926 is designed to operate with a maximum junction temperature of 125°C. The rise from the case to junction is determined by the power dissipation of the device. The power dissipation is determined by the V_{SS} current plus the operating I_{MOD} and I_{BIAS} currents.

The power of the chip is determined by the following formula:

$$P_D = (-V_{SS} * I_{SS}) + ((V_{IOUT} - V_{SS}) * I_{MOD}) + ((V_{IBIAS} - V_{SS}) * I_{BIAS})$$

For example with:

$$\begin{aligned} V_{SS} &= -5.2V \\ I_{MOD} &= 40mA \\ I_{BIAS} &= 20mA \\ V_{IBIAS} &= -2.0V \\ V_{IOUT} &= -2.0V \end{aligned}$$

$$P_D = (-5.2 * 220mA) + ((5.2 - 2.0) * 40mA) + ((5.2 - 2.0) * 20mA)$$

$$P_D = 1144mW + 128mW + 64mW = 1.336W$$

The thermal rise from junction to case is $\theta_{JC} * P_D$. For the ceramic package, $\theta_{JCC} = 25^\circ\text{C/W}$. Thus the thermal rise is:

$$25^\circ\text{C/W} * 1.336W = 33.4^\circ\text{C}$$

The maximum case temperature is:

$$125^\circ\text{C} - 33.4^\circ\text{C} = 91.6^\circ\text{C}$$

The absolute maximum power dissipation of the device is at:

$$\begin{aligned} V_{SS} &= -5.5V \\ I_{MOD} &= 60mA \\ I_{BIAS} &= 50mA \\ V_{IBIAS} &= 0V \\ V_{IOUT} &= 0V \end{aligned}$$

$$P_D = (5.5 * 220mA) + (5.5 * 60mA) + (5.5mA * 50mA)$$

$$P_D = 1.815W$$

This will net a maximum junction to case thermal rise of: $1.815W * 25^\circ\text{C/W} = 45.4^\circ\text{C}$

This situation will allow maximum case temperature of: $125^\circ\text{C} - 45.4^\circ\text{C} = 79.6^\circ\text{C}$

Preliminary Data Sheet

VSC7926

SDH/SONET 2.5Gb/s Laser Diode Driver

Figure 1: Control Signals VIP and VIB

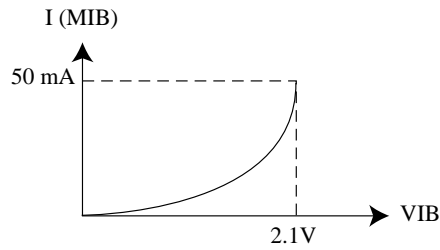

Typical Bias Current v.s. Bias Voltage

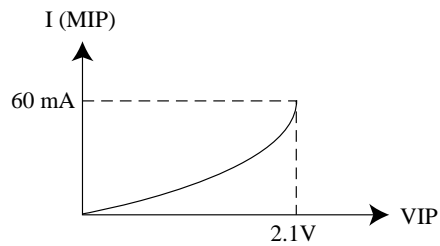

Typical Modulation Current v.s. Modulation Voltage

Figure 2: Simplified Output Structure

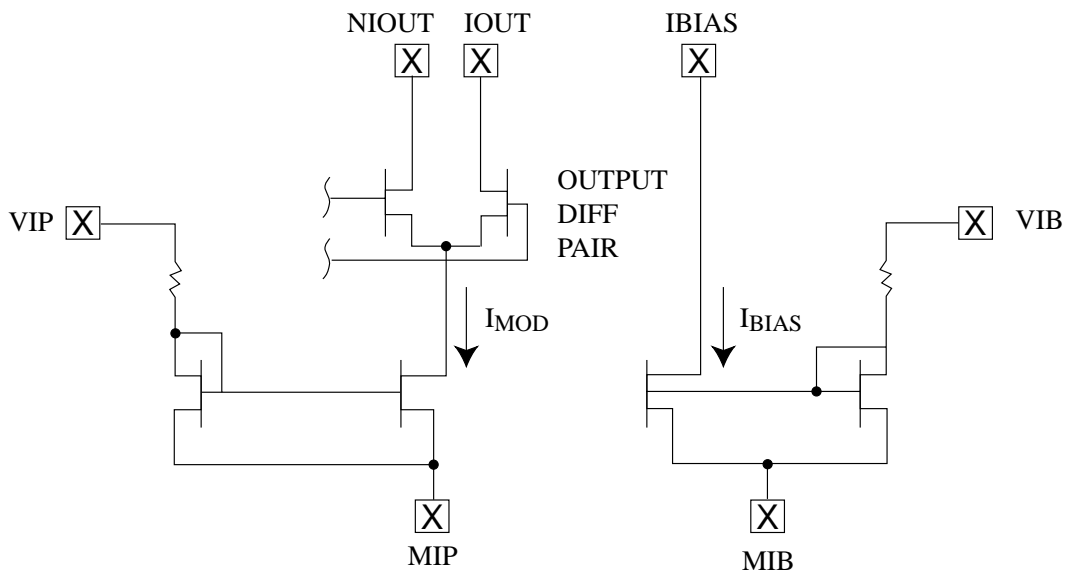
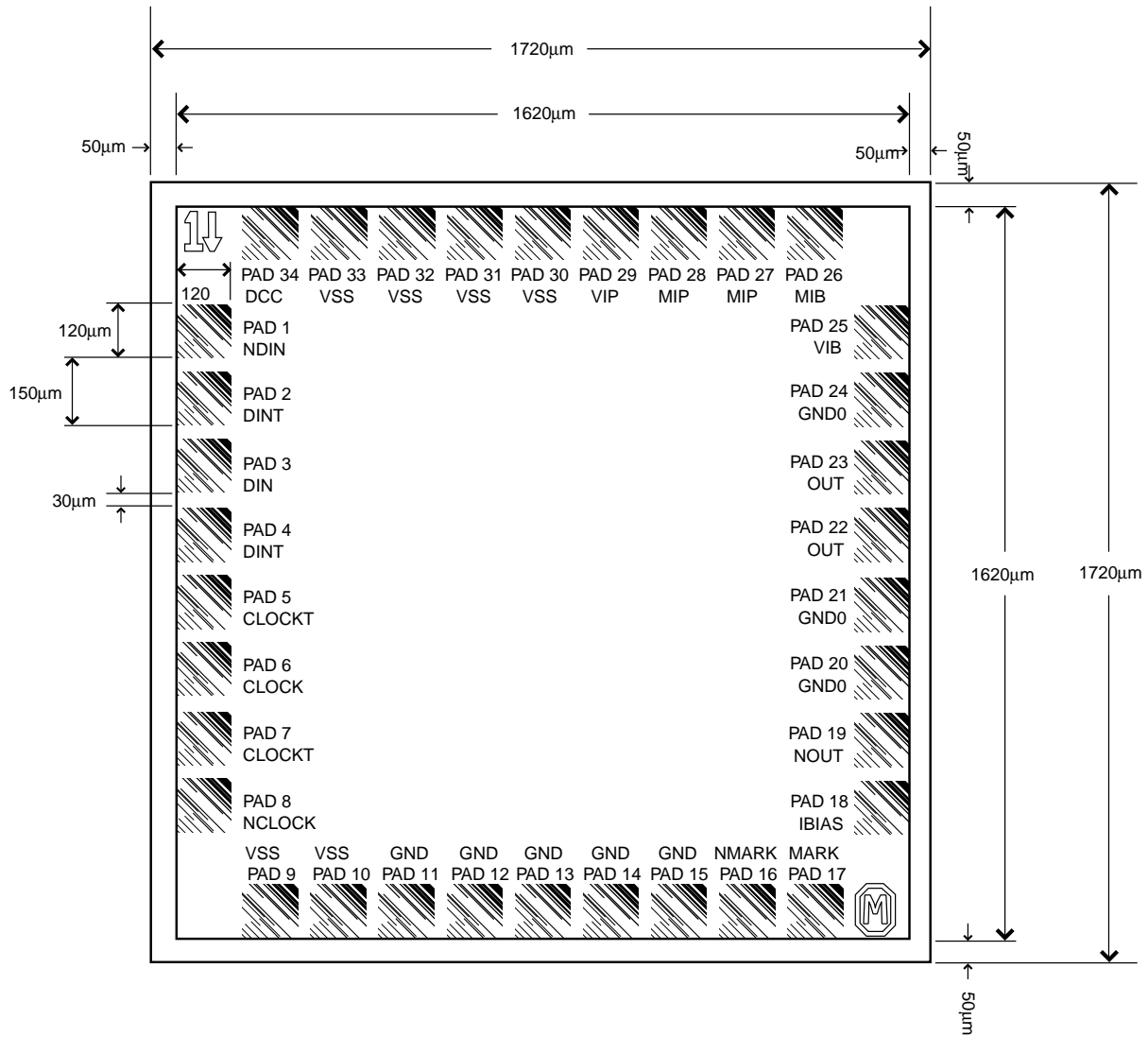

Figure 3: Pad Assignments for VSC7926 Die



Die Size: 1620µm x 1620µm
 Actual Die Size: 1720µm x 1720µm (after the die are cut up)
 Pad Size: 120µm x 120µm
 Pad Pitch: 150µm
 Space Between Pads: 30µm

Preliminary Data Sheet

VSC7926

SDH/SONET 2.5Gb/s Laser Diode Driver

Pin Diagram for 24-Pin Ceramic Package

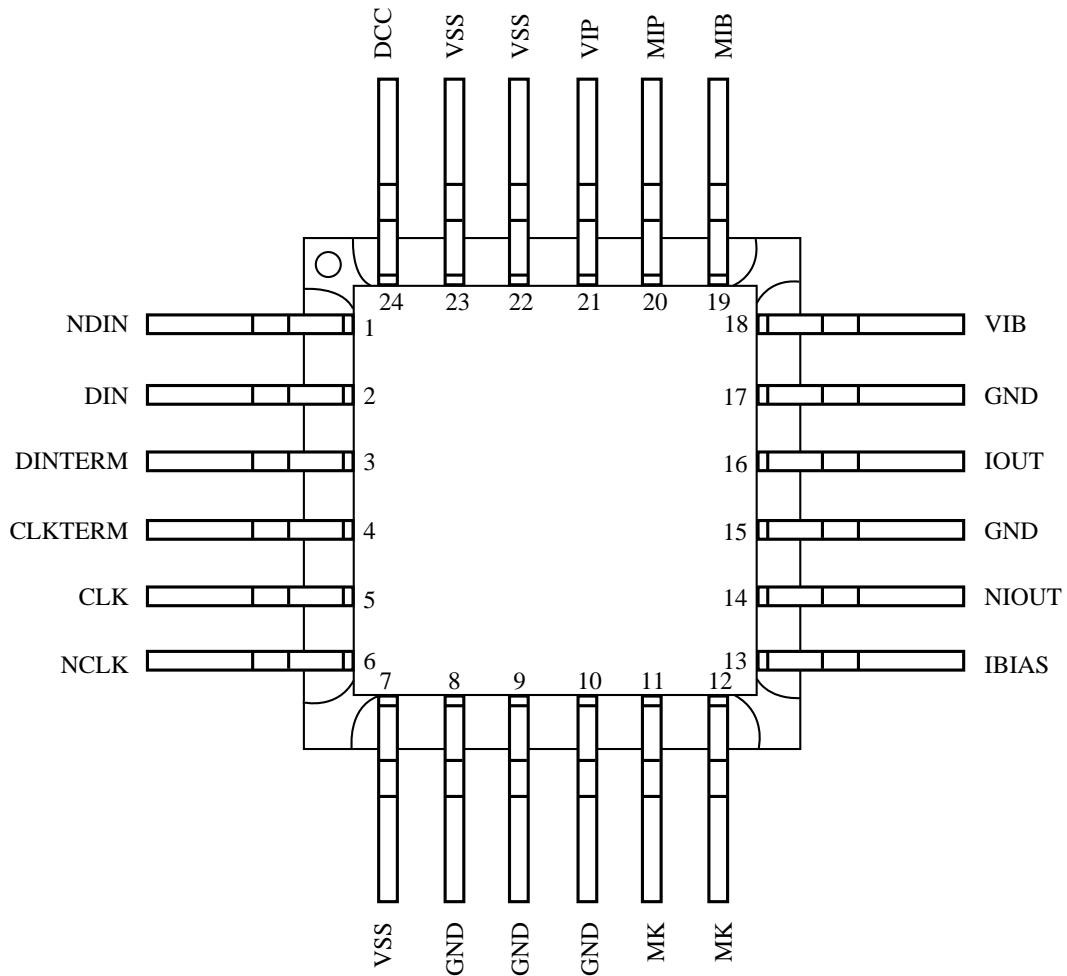

Note: Package lid and bottom heat spreader are electrically connected to GND within the package.

Package Information - 24-Pin Ceramic Package (Formed Leads)

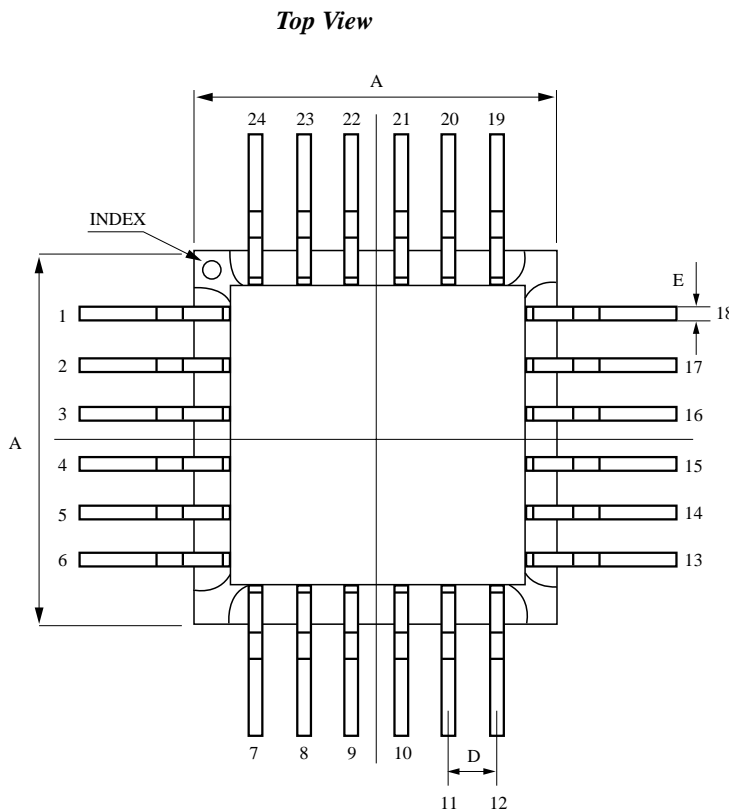

Key	mm	In
A	9.5	0.374
B	7.7	0.303
C	2.0	0.079
D	1.27	0.050
E	0.30	0.012
F	1.7	0.067
G	0.6	0.024
H	11.5	0.453
I	0.125	0.005
J	8.51	0.335

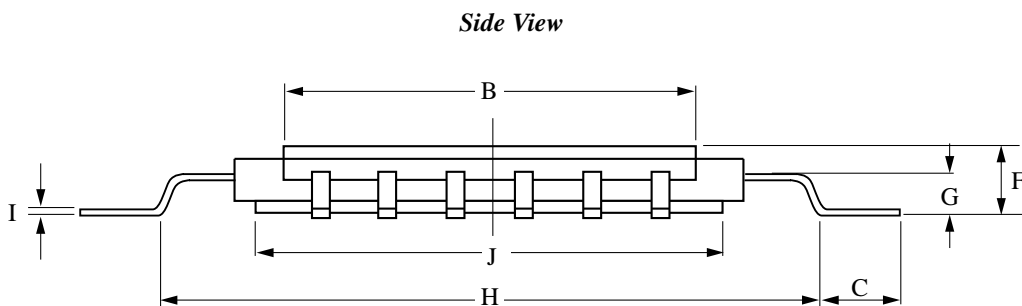

NOTES: Drawing not to scale.
Package #: 101-300-7, Issue #:1
Lid #: 101-303-1, Issue #:1

Preliminary Data Sheet

VSC7926

SDH/SONET 2.5Gb/s Laser Diode Driver

Package Information - 24-Pin Ceramic Package (Straight Leads)

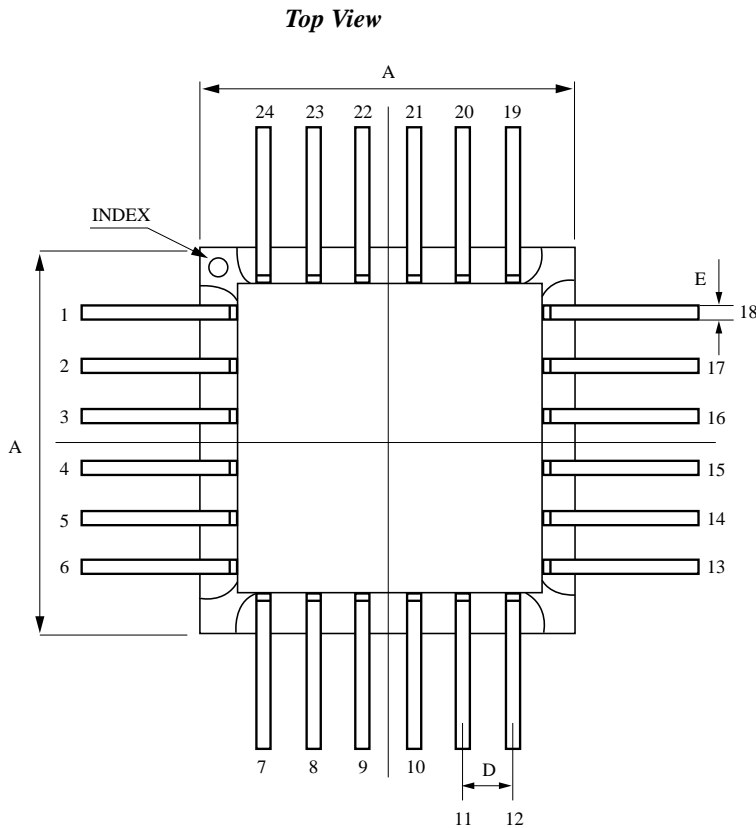

Key	mm	In
A	9.5	0.374
B	7.7	0.303
C	5.8	.230
D	1.27	0.050
E	0.30	0.012
F	1.7	0.067
G	0.6	0.024
H	9.53	0.375
I	0.125	0.005
J	8.51	0.335

Side View

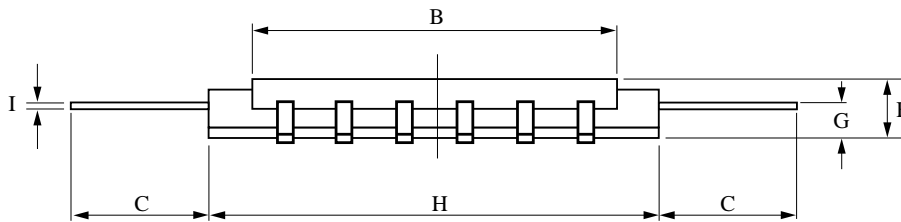

NOTES: Drawing not to scale.
Package #: 101-000-0 Issue #:1

Ordering Information

The order number for this product is formed by a combination of the device number, and package style.

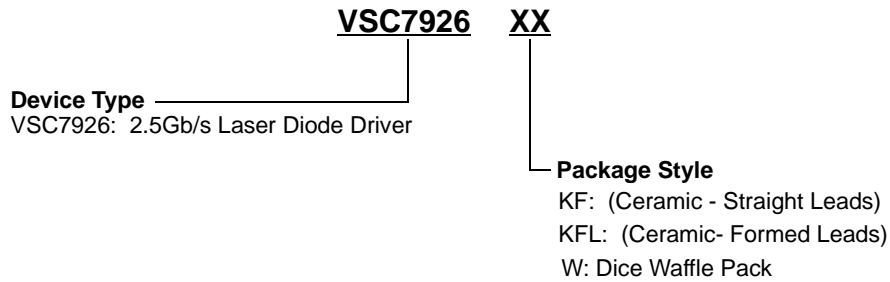

Notice

Vitesse Semiconductor Corporation ("Vitesse") provides this document for informational purposes only. This document contains pre-production information about Vitesse products in their concept, development and/or testing phase. All information in this document, including descriptions of features, functions, performance, technical specifications and availability, is subject to change without notice at any time. Nothing contained in this document shall be construed as extending any warranty or promise, express or implied, that any Vitesse product will be available as described or will be suitable for or will accomplish any particular task.

Vitesse products are not intended for use in life support appliances, devices or systems. Use of a Vitesse product in such applications without written consent is prohibited.