

## Preliminary Data Sheet

### VSC7937

Single Supply 2.5Gb/s Voltage Driver

#### Features

- Typical Rise Times of 100ps
- High-Speed Operation (Up to 2.5Gb/s NRZ Data)
- 3V Output Voltage Compliance
- Single-Ended or Differential Input Operation
- Single Power Supply: +5V or -5.2V
- Direct Access to Modulation and Bias FETs
- On-Die MUX for Clocked or Unclocked Applications
- On-Chip 50Ω Input Clock and Data Termination

#### Applications

- SONET/SDH @ 622Mb/s, 1.244Gb/s, 2.488Gb/s
- Full-Speed Fibre Channel (1.062Gb/s)

#### General Description

The VSC7937 is a single -5.2V supply, 2.5Gb/s voltage driver with direct access to the output modulation and bias FETs. The output stage can drive 60mA into 50Ω with adequate output voltage compliance. Output bias and modulation currents are set by external components allowing precision monitoring and setting of the output voltage levels.

#### VSC7937 Block Diagram

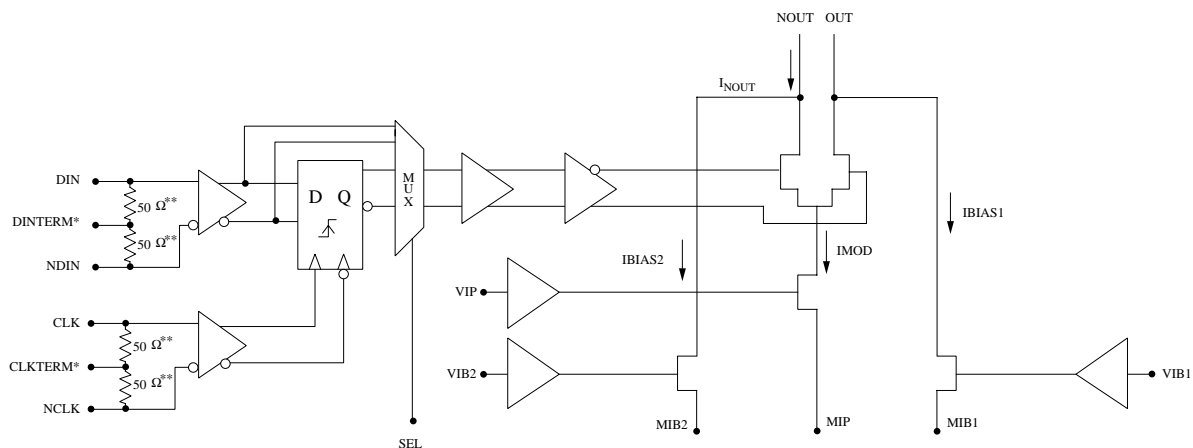

\*Terminated to Off-chip Capacitor  
\*\*On Die Components

### Electrical Characteristics

**Table 1: High-Speed Inputs and ECL Outputs**

$V_{SS} = -5.2V$ ,  $R_L = 50\Omega$  at  $I_{OUT}$  pin

Symbol	Parameter	Min	Typ	Max	Units	Conditions
$V_{IN}$	Single-Ended Input Voltage Swing	300	—	1500	mVp-p	$V_{CM} = -2.0V$
$V_{CM}$	Differential Input Common-Mode Range	-2.3	—	-1.3	V	$V_{SS} = -5.2V$
$V_{OH}$	ECL Output HIGH Voltage	-1200	—	—	mV	$50\Omega$ to $-2.0V$
$V_{OL}$	ECL Output LOW Voltage	—	—	-1600	mV	$50\Omega$ to $-2.0V$
$V_{IN}$	On-Chip Terminations	35	—	65	$\Omega$	
$I_{NOUT}$	Maximum Peak Current <sup>(1)</sup>	60	—	—	mA	VIP = $V_{SS} + 1.4V$ VIB1 = $-5.2V$ VIB2 = $-5.2V$ DIN = LOW
$I_{NOUT}$	Maximum Peak Current	—	—	4	mA	VIP = $-4.1V$ VIB1 = $-5.2V$ VIB2 = $-5.2V$ DIN = HIGH
$t_R, t_F$	Rise and Fall Times	—	—	100	ps	20% to 80%
$V_{OUT}$	Output Voltage	—	—	-3.0	V	VIP = $-4.1V$ VIB1 = $-5.2V$ VIB2 = $-5.2V$ DIN = LOW
$t_{SU}$	Set-up Time - Data to CLK	20	50	—	ps	
$t_H$	Hold Time	—	50	90	ps	

NOTE: (1) 100mA when  $R_L = 30\Omega$  at (N) OUT pin.

**Table 2: DC Characteristics**

Symbol	Parameter	Min	Typ	Max	Units	Conditions
$V_{SS}$	Power Supply Voltage	-5.5	-5.2	-4.75	V	
$I_{BIAS1}, I_{BIAS2}$	Maximum Bias Current	30	—	—	mA	VIB1, 2 = $V_{SS} + 1.8V$ VIP = $-5.2V$
$V_{DCC}$	Duty-Cycle Control Voltage	$V_{SS}$	—	$V_{SS} + 3V$	V	
$V_{IH}$	HIGH Level Input Voltage	-1.15	-0.9	-0.8	V	$V_{REF} = 1.3V$
$V_{IL}$	LOW Level Input Voltage	—	-1.7	-1.45	V	$V_{REF} = 1.3V$
VIB1, VIB2	BIAS Control Voltage	$V_{SS}$	—	$V_{SS} + 1.8$	V	
VIP	Modulation Control Voltage	$V_{SS}$	—	$V_{SS} + 1.4$	V	

## Preliminary Data Sheet

### VSC7937

Single Supply 2.5Gb/s Voltage Driver

**Table 3: Power Dissipation**

Symbol	Parameter	Min	Typ	Max	Units	Conditions
I <sub>SS</sub>	Power Supply Current (V <sub>SS</sub> )	—	—	120	mA	V <sub>SS</sub> = -5.5V, I <sub>MOD</sub> = I <sub>BIAS</sub> = 0mA
P <sub>D</sub>	Total Power Dissipation	—	—	700	mW	V <sub>SS</sub> = -5.5V, I <sub>MOD</sub> = I <sub>BIAS</sub> = 0 mA

**Table 4: Package Thermal Specifications**

Symbol	Parameter	Min	Typ	Max	Units	Conditions
θ <sub>JCC</sub>	Thermal Resistance from Junction to Case	—	25	—	°C/W	Ceramic Package
θ <sub>JCP</sub>	Thermal Resistance from Junction to Case	—	15	—	°C/W	Plastic Package

**Table 5: MUX Select Logic Table**

Symbol	Rating
V <sub>SS</sub>	Clocked Data In
GND	Non-clocked Data In
NC	Non-clocked Data In

### Absolute Maximum Ratings<sup>(1)</sup>

Power Supply Voltage (V<sub>SS</sub>) ..... V<sub>CC</sub> to -6.0V  
 Operating Junction Temperature Range (T<sub>J</sub>)..... -55°C to +125°C  
 Storage Temperature Range (T<sub>S</sub>)..... -65°C to +150°C

*NOTE: (1) CAUTION: Stresses listed under “Absolute Maximum Ratings” may be applied to devices one at a time without causing permanent damage. Functionality at or above the values listed is not implied. Exposure to these values for extended periods may affect device reliability.*

### Recommended Operating Conditions

Positive Voltage Rail (GND) ..... 0V  
 Negative Voltage Rail (V<sub>SS</sub>) ..... -5.2V  
 Operational Case Temperature Range (T<sub>C</sub>)<sup>(1)</sup> ..... -40°C to +85°C

*NOTE: (1) Lower limit of specification is ambient temperature and upper limit is case temperature*

**Figure 1: On-Chip Data and Clock Input Configuration**

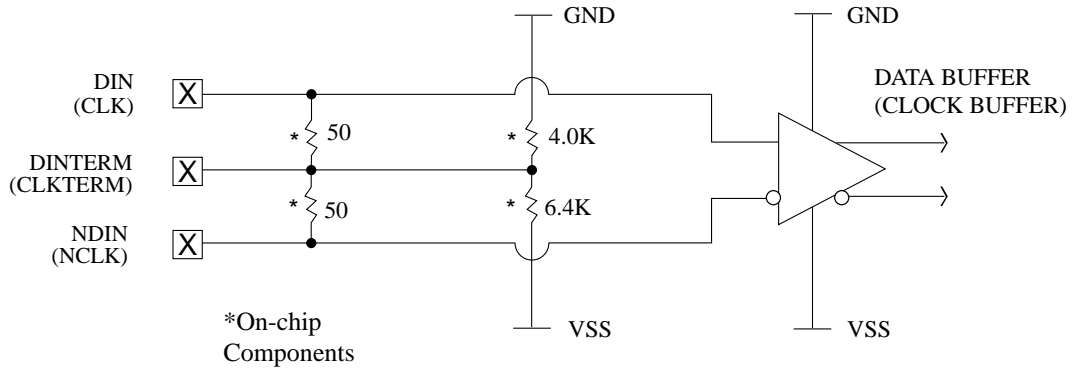

**Figure 2: Single-Ended Operation**

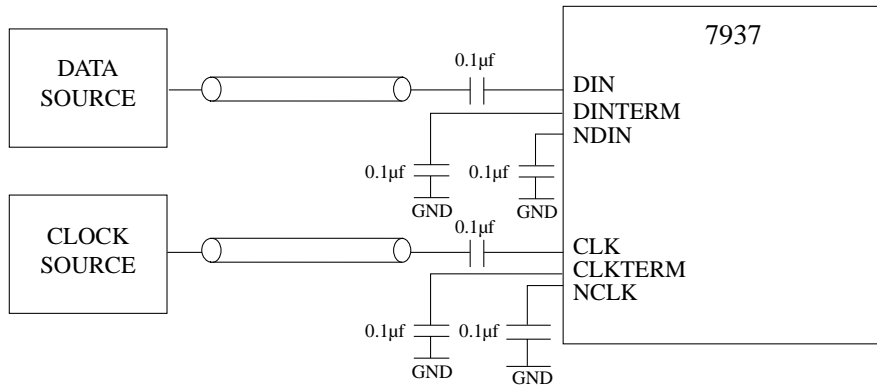

**Figure 3: Single-Ended AC-Coupled**

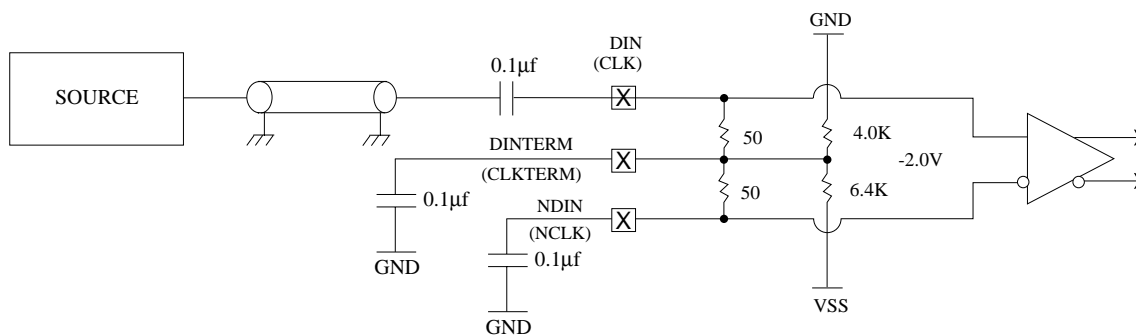

**Preliminary Data Sheet**

**VSC7937**

*Single Supply 2.5Gb/s Voltage Driver*

**Figure 4: Differential AC-Coupled**

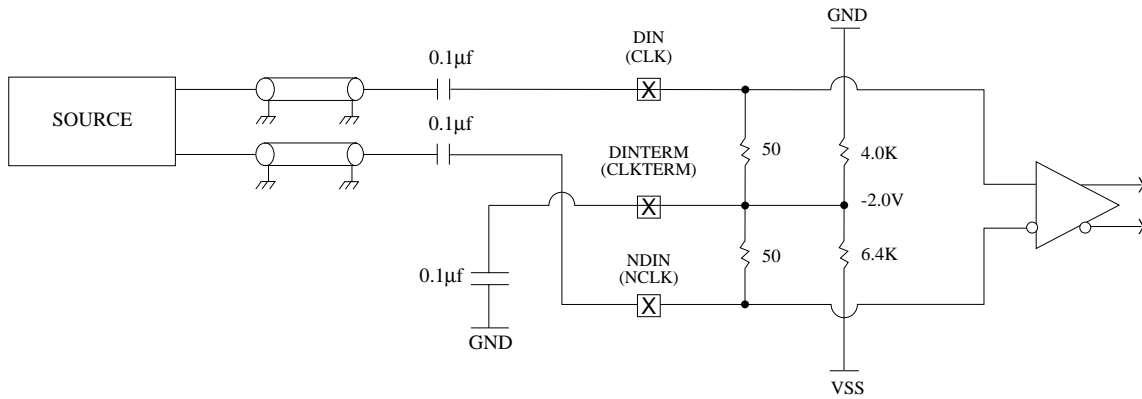

**Figure 5: Differential DC-Coupled/Differential ECL**

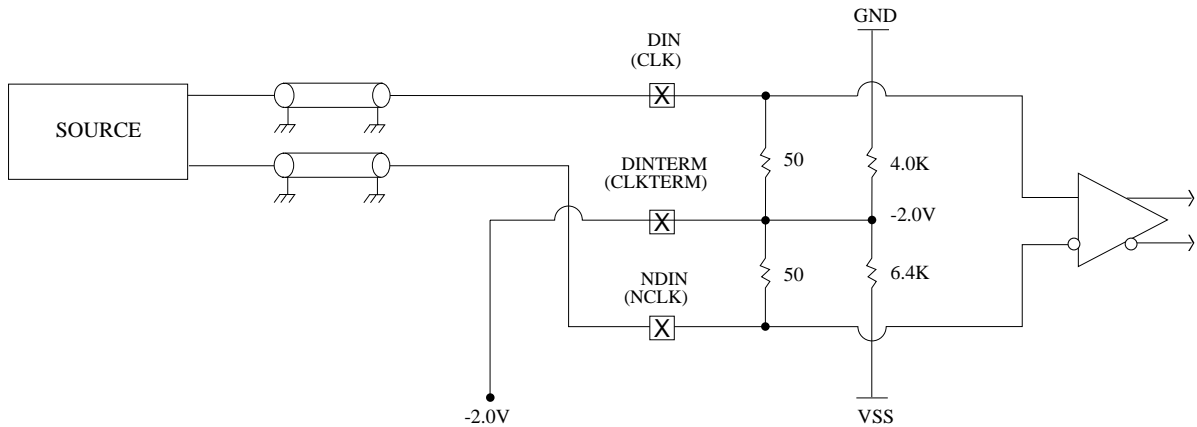

**Figure 6: Control Signals VIP and VIB**

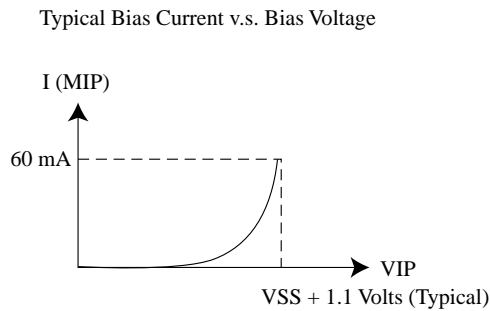
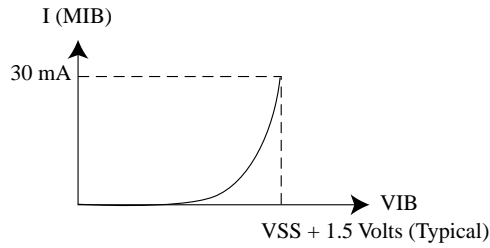

**Figure 7: Simplified Output Structure**

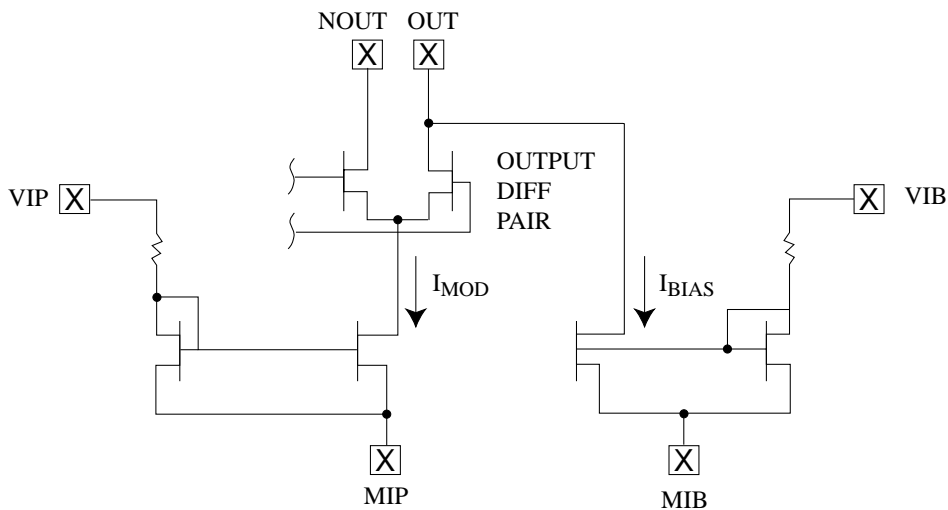

## Preliminary Data Sheet

### VSC7937

Single Supply 2.5Gb/s Voltage Driver

#### Bare Die Pad Descriptions

Figure 8: Pad Assignments for VSC7937 Die

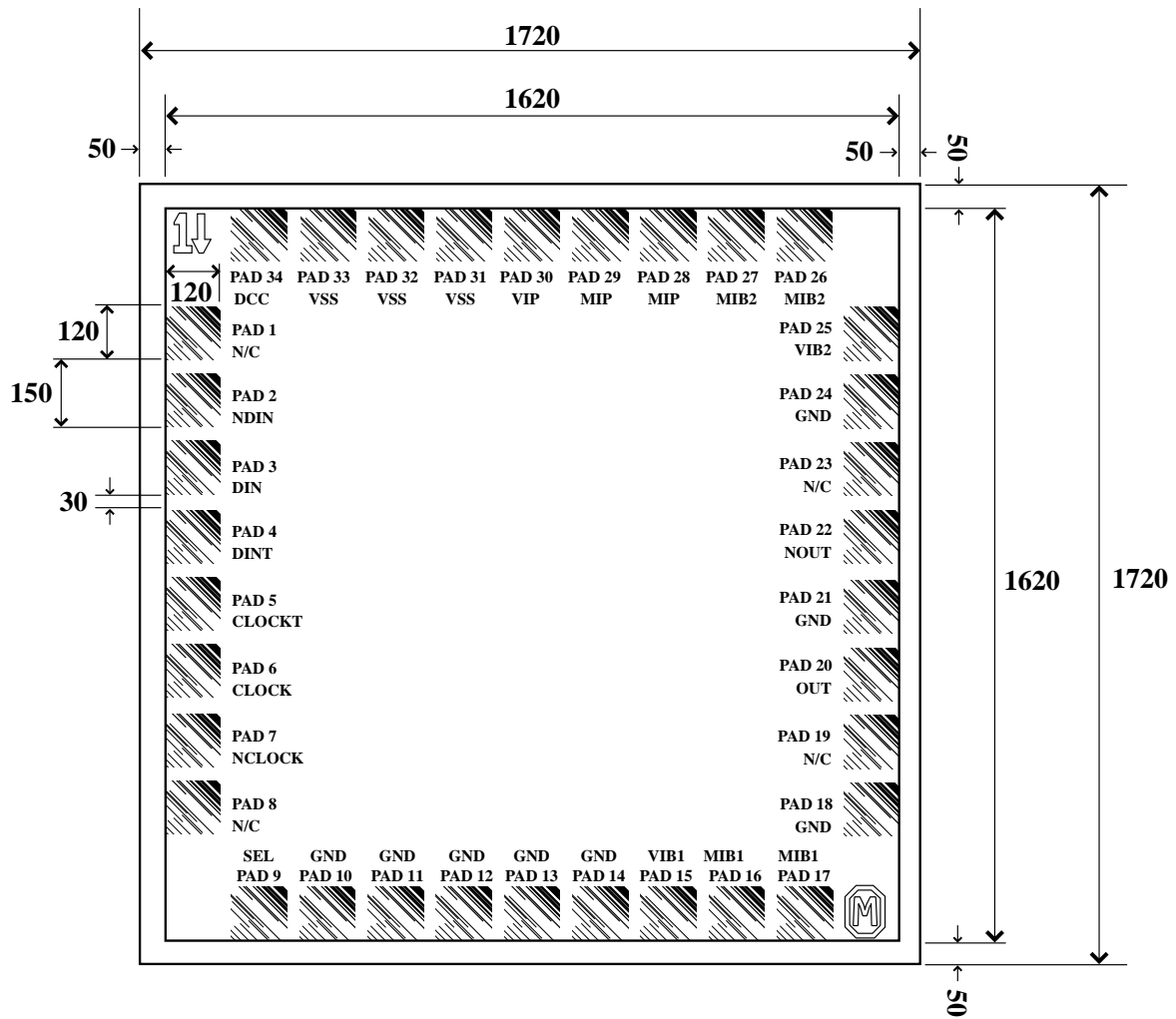

**Package Pin Information**

**Table 6: Pin Identifications**

<i>Signal</i>	<i>Type</i>	<i>Level</i>	<i># Pins</i>	<i>Description</i>
DIN, NDIN	In		2	Data Input and Data Reference
DINTERM	Ref	DC	1	Data Termination
CLK, NCLK	In		2	Clock Input and Clock Reference
CLKTERM	Ref	DC	1	Clock Termination
NOUT	Out		1	Modulation Current Output (complementary)
OUT	Out		1	Modulation Current Output (to Laser Cathode)
VSS	Pwr	Pwr	2	Negative Voltage Rail
GND	Pwr	Pwr	6/14 <sup>(1)</sup>	Positive Voltage Rail
VIP	In	DC	1	Modulation Control Node
MIP	In	DC	1	Modulation Monitor Node
VIB1, 2	In	DC	2	Bias Control Node
MIB1, 2	In	DC	2	Bias Monitor Node
DCC	In	DC	1	Duty Cycle Control
SEL	In	DC	1	Clk/Non-clk Data Select
Total Pins			24/32 <sup>(1)</sup>	

*NOTE: (1) Applicable to 32-pin TQFP package only*



**Preliminary Data Sheet**

**VSC7937**

Single Supply 2.5Gb/s Voltage Driver

**Figure 9: Pin Diagram—24-Pin Ceramic Package**

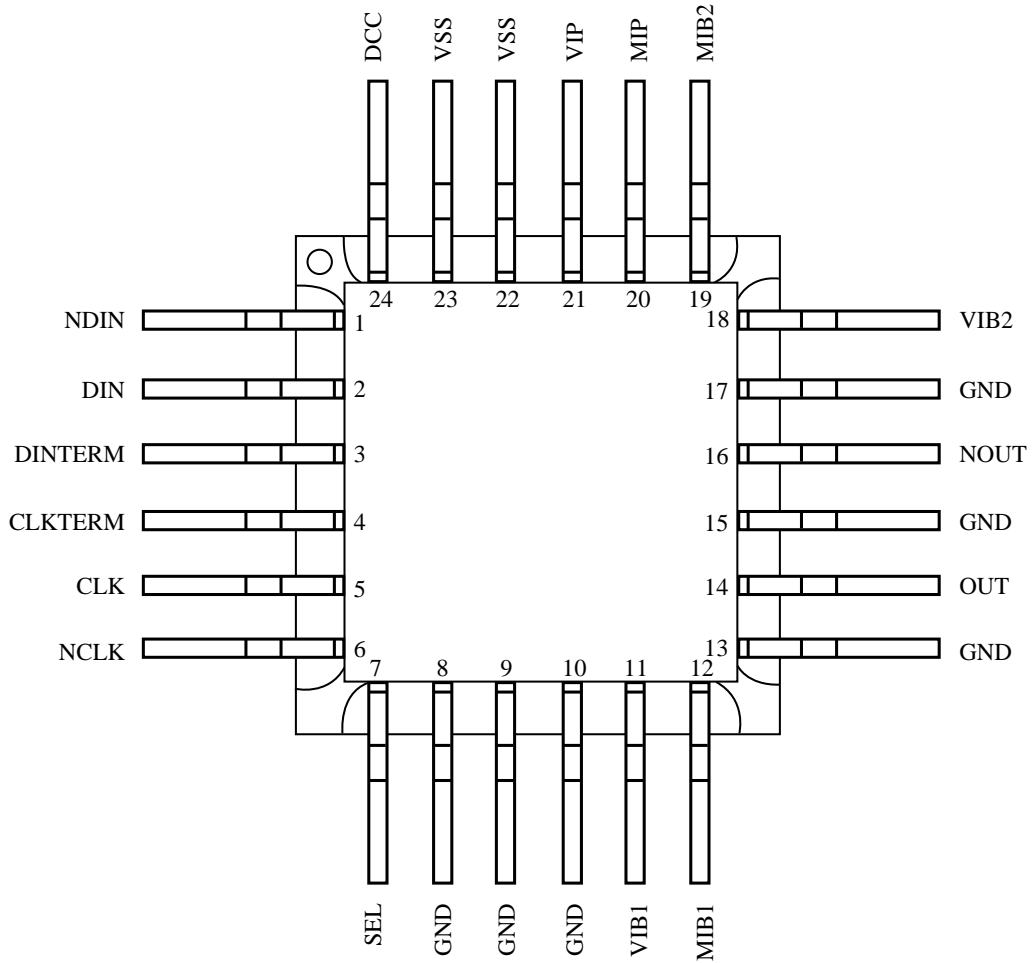

**Figure 10: Pin Diagram—32-Pin Plastic Package**

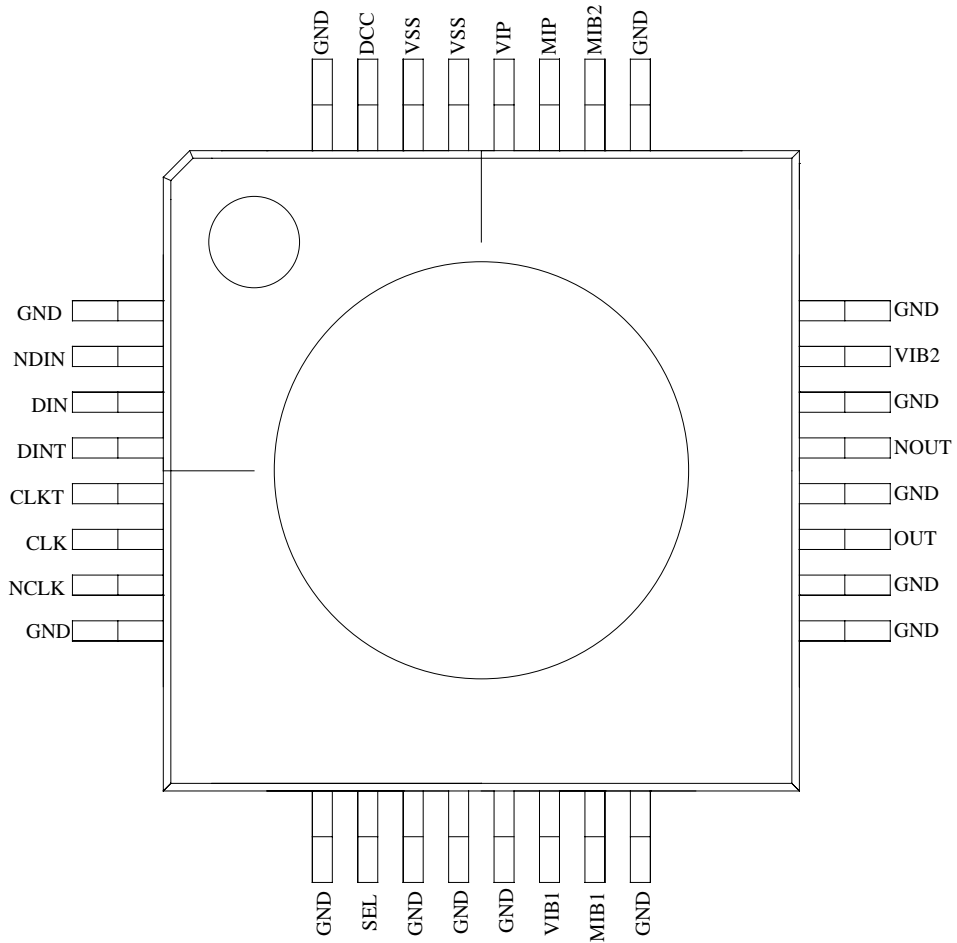

**Preliminary Data Sheet**

**VSC7937**

Single Supply 2.5Gb/s Voltage Driver

**Package Information—24-Pin Ceramic Package (Formed Leads)**

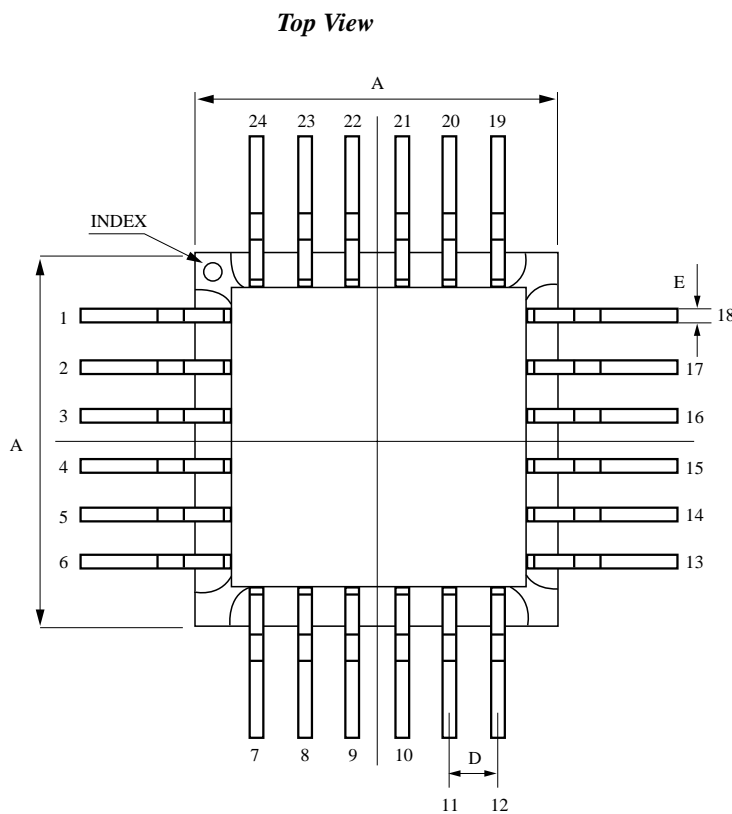

Key	mm	In
A	9.5	0.374
B	7.7	0.303
C	2.0	0.079
D	1.27	0.050
E	0.30	0.012
F	1.7	0.067
G	0.6	0.024
H	11.5	0.453
I	0.125	0.005
J	8.51	0.335

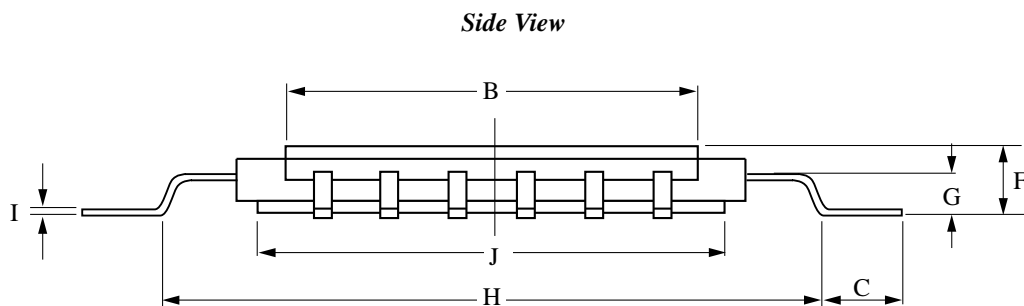

NOTES: Drawing not to scale.  
Package #: 101-000-0 Issue #: 1

### Package Information—24-Pin Ceramic Package (Straight Leads)

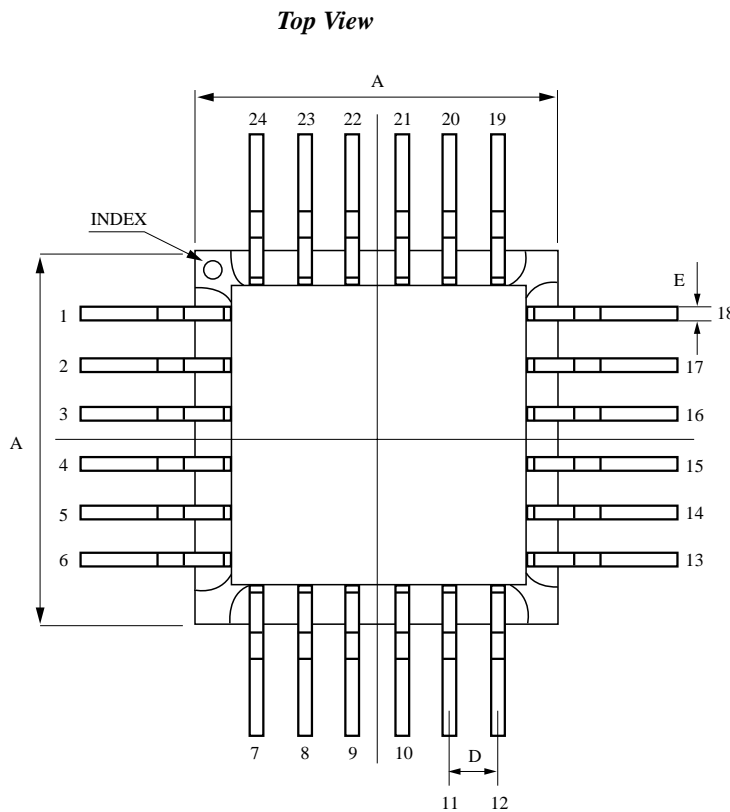

Key	mm	In
A	9.5	0.374
B	7.7	0.303
C	5.8	.230
D	1.27	0.050
E	0.30	0.012
F	1.7	0.067
G	0.6	0.024
H	9.53	0.375
I	0.125	0.005
J	8.51	0.335

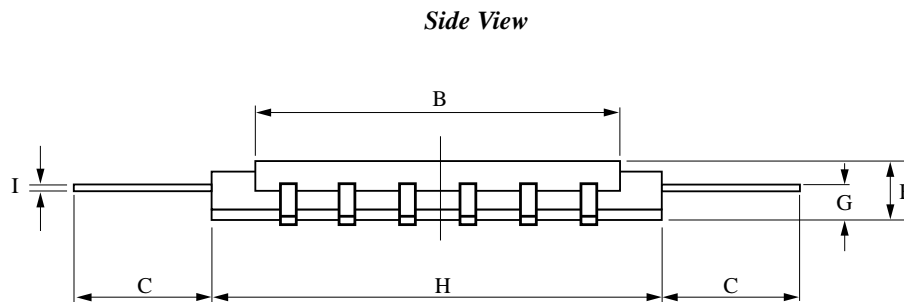

NOTES: Drawing not to scale.  
Package #: 101-000-0 Issue #: 1

## Preliminary Data Sheet

### VSC7937

Single Supply 2.5Gb/s Voltage Driver

#### Package Information—32 Pin Plastic TQFP Package

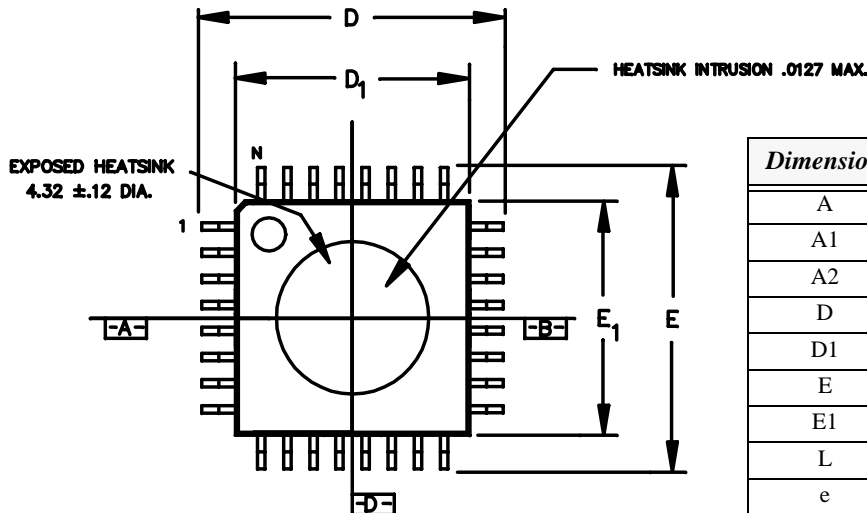

Dimension	mm	Tolerance
A	1.60	MAX
A1	.10	±.05
A2	1.40	±.05
D	9.00	±.20
D1	7.00	±.10
E	9.00	±.20
E1	7.00	±.10
L	.60	+ .15/- .10
e	.80	BASIC
b	.35	±.05
θ	0° - 7°	
ddd	.20	MAX
ccc	.10	MAX

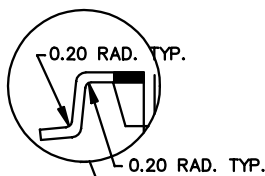
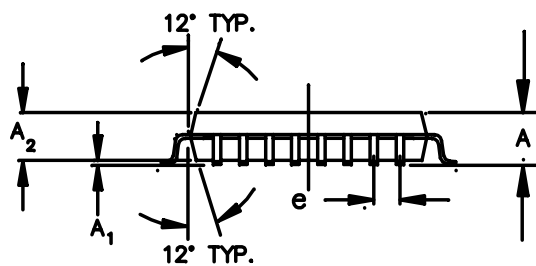

Note: Package lid and bottom heat spreader are electrically connected to GND within the package.

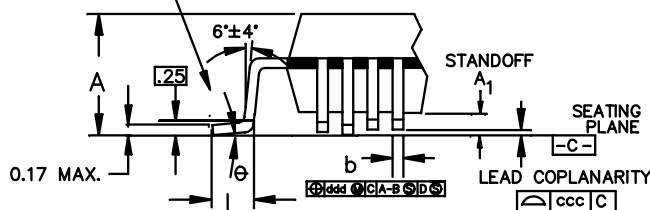

- NOTES:
- 1) ALL DIMENSIONS IN MM.
  - 2) DIMENSIONS SHOWN ARE NOMINAL WITH TOL. AS INDICATED
  - 3) L/F: EFTEC 64T COPPER OR EQUIVALENT, 0.127 MM (.005") THICK.
  - 4) FOOT LENGTH "L" IS MEASURED AT GAGE PLANE, AT 0.25 ABOVE THE SEATING PLANE.

## Ordering Information

The order number for this product is formed by a combination of the device number, and package style.

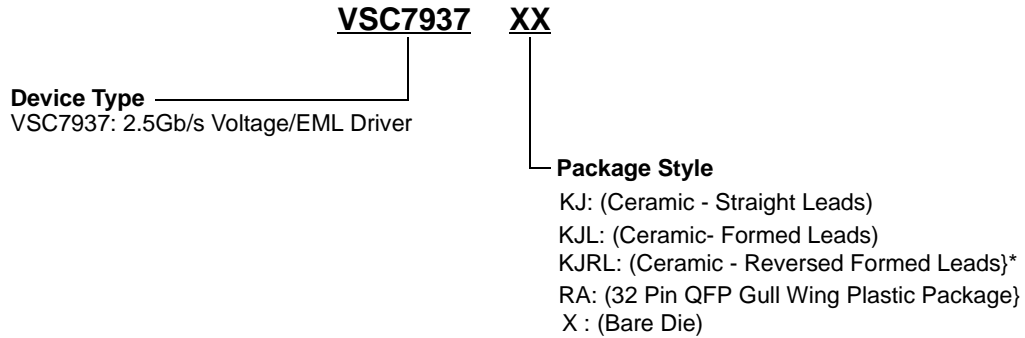

\*Optional Reversed Formed Leads: Package leads have the same profile and dimensions, but heat spreader is away from board. Please contact the factory for additional information.

## Notice

Vitesse Semiconductor Corporation ("Vitesse") provides this document for informational purposes only. This document contains pre-production information about Vitesse products in their concept, development and/or testing phase. All information in this document, including descriptions of features, functions, performance, technical specifications and availability, is subject to change without notice at any time. Nothing contained in this document shall be construed as extending any warranty or promise, express or implied, that any Vitesse product will be available as described or will be suitable for or will accomplish any particular task.

Vitesse products are not intended for use in life support appliances, devices or systems. Use of a Vitesse product in such applications without written consent is prohibited.