

## Description

The device is CMOS Dynamic RAM organized as 4,194,304 words x 4 bits. It is fabricated with an advanced submicron CMOS technology and designed to operate from a single 5V only or 3.3V only power supply. Low voltage operation is more suitable to be used on battery backup, portable electronic application. A new refresh feature called "self-refresh" is supported and very slow CBR cycles are being performed. It is packaged in JEDEC standard 26/24 - pin plastic SOJ or TSOP (II).

## Features

- Single 5V ( $\pm 10\%$ ) or 3.3V ( $\pm 10\%$ ) only power supply
- High speed  $t_{RAC}$  access time : 50/60 ns
- Low power dissipation
  - Active mode : 5V version 605/550 mW (Max.)  
3.3V version 396/360 mW (Max.)
  - Standby mode : 5V version 1.375 mW (Max.)  
3.3V version 0.54 mW (Max.)
- Fast Page Mode access
- I/O level : TTL compatible ( $V_{cc} = 5V$ )  
LVTTTL compatible ( $V_{cc} = 3.3V$ )
- 2048 refresh cycles in 32 ms (Std) or 128ms (S - version)
- 4 refresh mode :
  - $\overline{RAS}$  only refresh
  - $\overline{CAS}$ -before- $\overline{RAS}$  refresh
  - Hidden refresh
  - Self - refresh (S - version)

### Pin configuration

26/24 - PIN 300mil Plastic SOJ

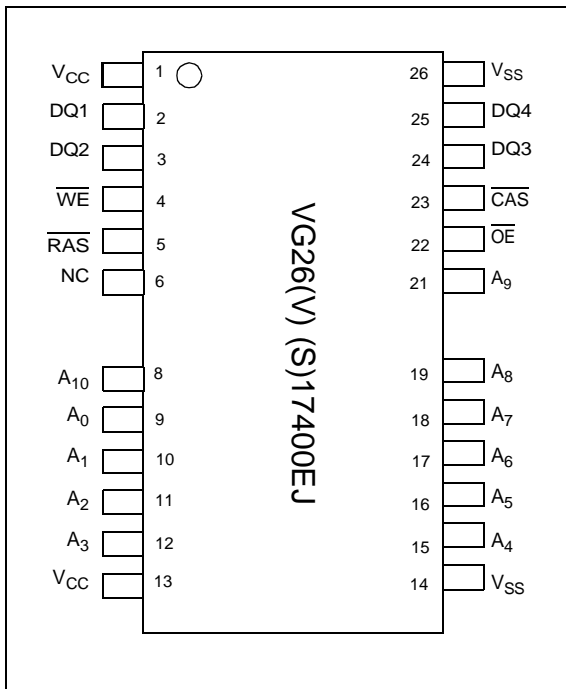

### Pin Description

Pin Name	Function
A0 - A10	Address inputs - Row address           A0 - A10 - Column address       A0 - A10 - Refresh address       A0 - A10
DQ1 ~ DQ4	Data - in/data - out
$\overline{RAS}$	Row address strobe
$\overline{CAS}$	Column address strobe
$\overline{WE}$	Write enable
$\overline{OE}$	Output enable
V <sub>CC</sub>	Power (+ 5V or + 3.3V)
V <sub>SS</sub>	Ground

**Block Diagram**

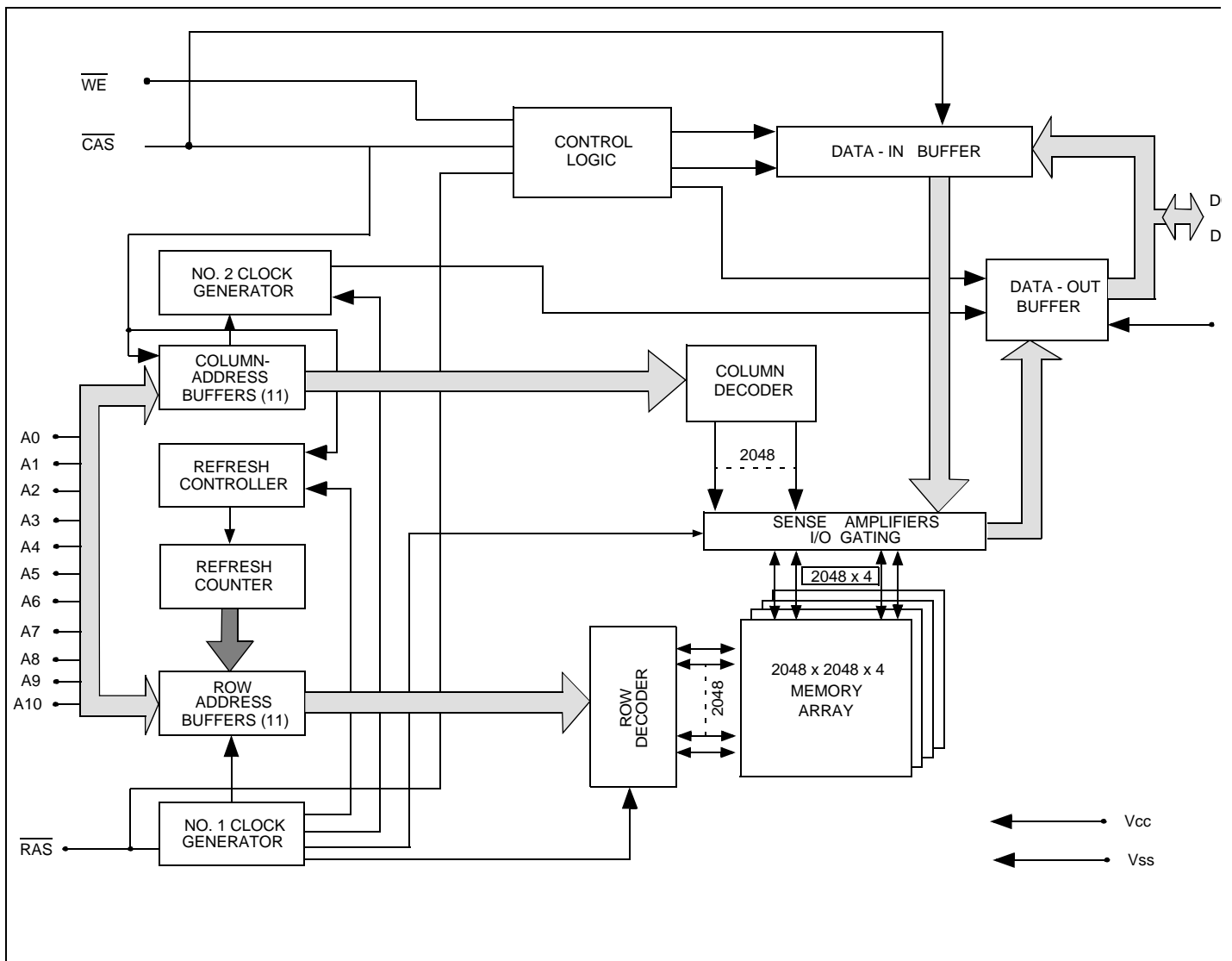

**Truth Table**

FUNCTION		$\overline{\text{RAS}}$	$\overline{\text{CAS}}$	$\overline{\text{WE}}$	$\overline{\text{OE}}$	ADDRESSES		DQ <sub>S</sub>	Notes
						ROW	COL		
STANDBY		H	H → X	X	X	X	X	High - Z	
READ		L	L	H	L	ROW	COL	Data - Out	
WRITE : (EARLY WRITE)		L	L	L	X	ROW	COL	Data - In	
READ WRITE		L	L	H → L	L → H	ROW	COL	Data - Out, Data - In	
PAGE - MODE READ	1st Cycle	L	H → L	H	L	ROW	COL	Data - Out	
	2st Cycle	L	H → L	H	L	n/a	COL	Data - Out	
PAGE - MODE WRITE	1st Cycle	L	H → L	L	X	ROW	COL	Data - In	
	2st Cycle	L	H → L	L	X	n/a	COL	Data - In	
PAGE - MODE READ - WRITE	1st Cycle	L	H → L	H → L	L → H	ROW	COL	Data - Out, Data - In	
	2st Cycle	L	H → L	H → L	L → H	n/a	COL	Data - Out, Data - In	
HIDDEN REFRESH	READ	L → H → L	L	H	L	ROW	COL	Data - Out	
	WRITE	L → H → L	L	L	X	ROW	COL	Data - In	1
RAS - ONLY REFRESH		L	H	X	X	ROW	n/a	High - Z	
CBR REFRESH		H → L	L	H	X	X	X	High - Z	

Notes : 1. EARLY WRITE only.

**Absolute Maximum Rating**

Parameter	Symbol	Value	Unit
Voltage on any pin relative to V <sub>ss</sub> 5V 3.3V	V <sub>T</sub>	-1.0 to + 7.0 -0.5 to + 4.6	V
Supply voltage relative to V <sub>ss</sub> 5V 3.3V	V <sub>cc</sub>	-1.0 to + 7.0 -0.5 to + 4.6	V
Short circuit output current	I <sub>OUT</sub>	50	mA
Power dissipation	P <sub>D</sub>	1.0	W
Operating temperature	T <sub>OPT</sub>	0 to + 70	°C
Storage temperature	T <sub>STG</sub>	-55 to + 125	°C

**Recommended DC Operating Conditions**

Parameter/Condition	Symbol	5 Volt Version			3.3 Volt Version			Unit
		Min	Typ	Max	Min	Typ	Max	
Supply Voltage	V <sub>cc</sub>	4.5	5.0	5.5	3.0	3.3	3.6	V
Input High Voltage, all inputs	V <sub>IH</sub>	2.4	-	V <sub>CC</sub> + 1.0	2.0	-	V <sub>CC</sub> + 0.3	V
Input Low Voltage, all inputs	V <sub>IL</sub>	-1.0	-	0.8	-0.3	-	0.8	V

**Capacitance**

T<sub>a</sub> = 25°C, V<sub>CC</sub> = 5V±10% or 3.3V±10%, f = 1MHz

Parameter	Symbol	Typ	Max	Unit	Note
Input capacitance (Address)	C <sub>I1</sub>	-	5	pF	1
Input capacitance (RAS, CAS, OE, WE)	C <sub>I2</sub>	-	7	pF	1
Output capacitance (Data - in, Data - out)	C <sub>I/O</sub>	-	7	pF	1,2

Note : 1. Capacitance measured with effective capacitance measuring method.

2. CAS = V<sub>IH</sub> to disable Dout.

**DC Characteristics; 5 - Volt verion**

( $T_a = 0$  to  $70^\circ\text{C}$ ,  $V_{CC} = +5\text{V} \pm 10\%$ ,  $V_{SS} = 0\text{V}$ )

Parameter		Symbol	Test Conditions	VG26 (V) (S) 17400E				Unit	Notes
				-5		-6			
				Min	Max	Min	Max		
Operating current		$I_{CC1}$	$\overline{\text{RAS}}$ cycling CAS cycling $t_{RC} = \text{min.}$	-	110	-	100	mA	1, 2
Standby Current	Low power S - version	$I_{CC2}$	TTL interface RAS, CAS = $V_{IH}$ Dout = high - Z	-	2	-	2	mA	
			CMOS interface RAS, CAS $\geq V_{CC} - 0.2\text{V}$ Dout = high - Z	-	0.25	-	0.25	mA	
	Standard power version		TTL interface RAS, CAS = $V_{IH}$ Dout = high - Z	-	2	-	2	mA	
			CMOS interface RAS, CAS $\geq V_{CC} - 0.2\text{V}$ Dout = high - Z	-	1	-	1	mA	
RAS - only refresh current		$I_{CC3}$	RAS cycling, CAS = $V_{IH}$ $t_{RC} = \text{min.}$	-	110	-	100	mA	1, 2
Fast page mode current		$I_{CC4}$	$t_{PC} = \text{min.}$	-	80	-	70	mA	1,3
CAS - before - RAS refresh current		$I_{CC5}$	$t_{RC} = \text{min.}$ RAS, CAS cycling	-	110	-	100	mA	1, 2
Self - refresh currant (S - Version)		$I_{CC8}$	$t_{RASS} \geq 100\mu\text{S}$	-	350	-	350	$\mu\text{A}$	
CAS - before - RAS long refresh current (S - Version)		$I_{CC9}$	Standby : $V_{CC} - 0.2\text{V} \leq \overline{\text{RAS}}$ CAS before RAS refresh : 2048 cycles/128ms RAS, RAS : $0\text{V} \leq V_{IL} \leq 0.2\text{V}$ $V_{CC} - 0.2\text{V} \leq V_{IH} \leq V_{IH} (\text{Max})$ Dout = high - Z, $t_{RAS} \leq 300\text{ns}$	-	500	-	500	$\mu\text{A}$	

**DC Characteristics ; 5 - Volt Version (cont.)**

( $T_a = 0$  to  $70^\circ\text{C}$ ,  $V_{CC} = +5\text{V} \pm 10\%$ ,  $V_{SS} = 0\text{V}$ )

Parameter	Symbol	Test Conditions	VG26 (V) (S) 17400E				Unit	Notes
			-5		-6			
			Min	Max	Min	Max		
Input leakage current	$I_{LI}$	$0\text{V} \leq V_{in} \leq V_{CC} + 0.5\text{V}$	-5	5	-5	5	$\mu\text{A}$	
Output leakage current	$I_{LO}$	$0\text{V} \leq V_{out} \leq V_{CC} + 0.5\text{V}$ Dout = Disable	-5	5	-5	5	$\mu\text{A}$	
Output high voltage	$V_{OH}$	$I_{OH} = -5\text{mA}$	2.4	-	2.4	-	V	
Output low voltage	$V_{OL}$	$I_{OL} = +4.2\text{mA}$	-	0.4	-	0.4	V	

**Notes :**

1.  $I_{CC}$  is specified as an average current. It depends on output loading condition and cycle rate when the device is selected.  $I_{CC}$  max is specified at the output open condition.
2. Address can be changed once or less while  $\overline{\text{RAS}} = V_{IL}$ .
3. For  $I_{CC4}$ , address can be changed once or less within one Fast page mode cycle time.

**DC Characteristics ; 3.3 - Volt Verion**

( $T_a = 0$  to  $70^\circ\text{C}$ ,  $V_{CC} = + 3.3\text{V} \pm 10\%$ ,  $V_{SS} = 0\text{V}$ )

Parameter		Symbol	Test Conditions	VG26 (V) (S) 17400E				Unit	Notes
				-5		-6			
				Min	Max	Min	Max		
Operating current		$I_{CC1}$	$\overline{\text{RAS}}$ cycling CAS cycling $t_{RC} = \text{min.}$	-	110	-	100	mA	1, 2
Standby Current	Low power S - version	$I_{CC2}$	LVTTTL interface $\overline{\text{RAS}}, \overline{\text{CAS}} = V_{IH}$ Dout = high - Z	-	0.5	-	0.5	mA	
			CMOS interface $\overline{\text{RAS}}, \overline{\text{CAS}} \geq V_{CC} - 0.2\text{V}$ Dout = high - Z	-	0.25	-	0.25	mA	
	Standard power version		LVTTTL interface $\overline{\text{RAS}}, \overline{\text{CAS}} = V_{IH}$ Dout = high - Z	-	2	-	2	mA	
			CMOS interface $\overline{\text{RAS}}, \overline{\text{CAS}} \geq V_{CC} - 0.2\text{V}$ Dout = high - Z	-	0.5	-	0.5	mA	
RAS - only refresh current		$I_{CC3}$	$\overline{\text{RAS}}$ cycling, $\overline{\text{CAS}} = V_{IH}$ $t_{RC} = \text{min.}$	-	110	-	100	mA	1, 2
Fast page mode current		$I_{CC4}$	$t_{PC} = \text{min.}$	-	80	-	70	mA	1,3
CAS - before - RAS refresh current		$I_{CC5}$	$t_{RC} = \text{min.}$ RAS, CAS cycling	-	110	-	100	mA	1, 2
Self - refresh currant (S - Version)		$I_{CC8}$	$t_{RASS} \geq 100\mu\text{S}$	-	250	-	250	$\mu\text{A}$	
CAS - before - RAS long refresh current (S - Version)		$I_{CC9}$	Standby : $V_{CC} - 0.2\text{V} \leq \overline{\text{RAS}}$ CAS before RAS refresh : 2048 cycles/128ms RAS, RAS : $0\text{V} \leq V_{IL} \leq 0.2\text{V}$ $V_{CC} - 0.2\text{V} \leq V_{IH} \leq V_{IH}$ (Max) Dout = high - Z, $t_{RAS} \leq 300\text{ns}$	-	300	-	300	$\mu\text{A}$	



**DC Characteristics ; 3.3 - Volt Version (cont.)**

( $T_a = 0$  to  $70^\circ\text{C}$ ,  $V_{CC} = + 3.3\text{V} \pm 10\%$ ,  $V_{SS} = 0\text{V}$ )

Parameter	Symbol	Test Conditions	VG26 (V) (S) 17400E				Unit	Notes
			-5		-6			
			Min	Max	Min	Max		
Input leakage current	$I_{LI}$	$0\text{V} \leq V_{in} \leq V_{CC} + 0.3\text{V}$	-5	5	-5	5	$\mu\text{A}$	
Output leakage current	$I_{LO}$	$0\text{V} \leq V_{out} \leq V_{CC} + 0.3\text{V}$ Dout = Disable	-5	5	-5	5	$\mu\text{A}$	
Output high voltage	$V_{OH}$	$I_{OH} = -2\text{mA}$	2.4	-	2.4	-	V	
Output low voltage	$V_{OL}$	$I_{OL} = + 2\text{mA}$	-	0.4	-	0.4	V	

**Notes :**

- $I_{CC}$  is specified as an average current. It depends on output loading condition and cycle rate when the device is selected.  $I_{CC}$  max is specified at the output open condition.
- Address can be changed once or less while  $\overline{\text{RAS}} = V_{IL}$ .
- For  $I_{CC4}$ , address can be changed once or less within one Fast page mode cycle time.

**AC Characteristics**

( $T_a = 0$  to  $+70^\circ\text{C}$ ,  $V_{CC} = 5\text{V} \pm 10\%$  or  $3.3\text{V} \pm 10\%$ ,  $V_{SS} = 0\text{V}$ ) \* 1, \* 2, \* 3, \* 4

Test conditions

- Output load : two TTL Loads and 100pF ( $V_{CC} = 5.0\text{V} \pm 10\%$ )  
                   one TTL Load and 100pF ( $V_{CC} = 3.3\text{V} \pm 10\%$ )
- Input timing reference levels :  
 $V_{IH} = 2.4\text{V}$ ,  $V_{IL} = 0.8\text{V}$  ( $V_{CC} = 5.0\text{V} \pm 10\%$ );  $V_{IH} = 2.0\text{V}$ ,  $V_{IL} = 0.8\text{V}$  ( $V_{CC} = 3.3\text{V} \pm 10\%$ )
- Output timing reference levels :  
 $V_{OH} = 2.0\text{V}$ ,  $V_{OL} = 0.8\text{V}$  ( $V_{CC} = 5\text{V} \pm 10\%$ ,  $3.3\text{V} \pm 10\%$ )

**Read, Write, Read - Modify - Write and Refresh Cycles**  
**(Common Parameters)**

Parameter	Symbol	VG26 (V) (S) 17400E				Unit	Notes
		-5		-6			
		Min	Max	Min	Max		
Random read or write cycle time	$t_{RC}$	90	-	110	-	ns	
$\overline{\text{RAS}}$ precharge time	$t_{RP}$	30	-	40	-	ns	
$\overline{\text{CAS}}$ precharge time in normal mode	$t_{CPN}$	10	-	10	-	ns	
$\overline{\text{RAS}}$ pulse width	$t_{RAS}$	50	10000	60	10000	ns	5
$\overline{\text{CAS}}$ pulse width	$t_{CAS}$	12	10000	15	10000	ns	6
Row address setup time	$t_{ASR}$	0	-	0	-	ns	
Row address hold time	$t_{RAH}$	8	-	10	-	ns	
Column address setup time	$t_{ASC}$	0	-	0	-	ns	7
Column address hold time	$t_{CAH}$	8	-	10	-	ns	
$\overline{\text{RAS}}$ to $\overline{\text{CAS}}$ delay time	$t_{RCD}$	12	37	14	45	ns	8
$\overline{\text{RAS}}$ to column address delay time	$t_{RAD}$	10	25	12	30	ns	9
Column address to $\overline{\text{RAS}}$ lead time	$t_{RAL}$	25	-	30	-	ns	
$\overline{\text{RAS}}$ hold time	$t_{RSH}$	13	-	15	-	ns	
$\overline{\text{CAS}}$ hold time	$t_{CSH}$	50	-	60	-	ns	
$\overline{\text{CAS}}$ to $\overline{\text{RAS}}$ precharge time	$t_{CRP}$	5	-	5	-	ns	10
$\overline{\text{OE}}$ to $\text{Din}$ delay time	$t_{OED}$	12	-	15	-	ns	
Transition time (rise and fall)	$t_T$	1	50	1	50	ns	11
Refresh period	$t_{REF}$	-	32	-	32	ms	
Refresh period (S - Version)	$t_{REF}$	-	128	-	128	ms	
$\overline{\text{CAS}}$ to output in Low-Z	$t_{CLZ}$	0	-	0	-	ns	
$\overline{\text{CAS}}$ delay time from $\text{Din}$	$t_{DZC}$	0	-	0	-	ns	
$\overline{\text{OE}}$ delay time from $\text{Din}$	$t_{DZO}$	0	-	0	-	ns	

**Read Cycle**

Parameter	Symbol	VG26 (V) (S) 17400E				Unit	Notes
		-5		-6			
		Min	Max	Min	Max		
Access time from $\overline{\text{RAS}}$	$t_{\text{RAC}}$	-	50	-	60	ns	12
Access time from $\overline{\text{CAS}}$	$t_{\text{CAC}}$	-	13	-	15	ns	13,14
Access time from column address	$t_{\text{AA}}$	-	25	-	30	ns	14,15
Access time from $\overline{\text{OE}}$	$t_{\text{OEA}}$	-	13	-	15	ns	
Read command setup time	$t_{\text{RCS}}$	0	-	0	-	ns	7
Read command hold time to $\overline{\text{CAS}}$	$t_{\text{RCH}}$	0	-	0	-	ns	10,16
Read command hold time to $\overline{\text{RAS}}$	$t_{\text{RRH}}$	0	-	0	-	ns	16
Output buffer turn-off time	$t_{\text{OFF}}$	0	13	0	15	ns	17
Output buffer turn-off time from $\overline{\text{OE}}$	$t_{\text{OEZ}}$	0	13	0	15	ns	17

**Write Cycle**

Parameter	Symbol	VG26 (V) (S) 17400E				Unit	Notes
		-5		-6			
		Min	Max	Min	Max		
Write command setup time	$t_{\text{WCS}}$	0	-	0	-	ns	7,18
Write command hold time	$t_{\text{WCH}}$	8	-	10	-	ns	
Write command pulse width	$t_{\text{WP}}$	8	-	10	-	ns	
Write command to $\overline{\text{RAS}}$ lead time	$t_{\text{RWL}}$	13	-	15	-	ns	
Write command to $\overline{\text{CAS}}$ lead time	$t_{\text{CWL}}$	8	-	10	-	ns	
Data-in setup time	$t_{\text{DS}}$	0	-	0	-	ns	19
Data-in hold time	$t_{\text{DH}}$	8	-	10	-	ns	19

**Read - Modify - Write Cycle**

Parameter	Symbol	VG26 (V) (S) 17400E				Unit	Notes
		-5		-6			
		Min	Max	Min	Max		
Read - modify - write cycle time	$t_{\text{RWC}}$	125	-	150	-	ns	
$\overline{\text{RAS}}$ to $\overline{\text{WE}}$ delay time	$t_{\text{RWD}}$	65	-	80	-	ns	18
$\overline{\text{CAS}}$ to $\overline{\text{WE}}$ delay time	$t_{\text{CWD}}$	30	-	35	-	ns	18
Column address to $\overline{\text{WE}}$ delay time	$t_{\text{AWD}}$	40	-	50	-	ns	18
$\overline{\text{OE}}$ hold time from $\overline{\text{WE}}$	$t_{\text{OEH}}$	8	-	10	-	ns	

**Refresh Cycle**

Parameter	Symbol	VG26 (V) (S) 17400E				Unit	Notes
		-5		-6			
		Min	Max	Min	Max		
$\overline{\text{CAS}}$ setup time (CBR refresh)	$t_{\text{CSR}}$	10	-	10	-	ns	
$\overline{\text{CAS}}$ hold time (CBR refresh)	$t_{\text{CHR}}$	10	-	10	-	ns	10
$\overline{\text{RAS}}$ precharge to $\overline{\text{CAS}}$ hold time	$t_{\text{RPC}}$	5	-	5	-	ns	7
$\overline{\text{RAS}}$ pulse width (self refresh)	$t_{\text{RASS}}$	100	-	100	-	$\mu\text{s}$	
$\overline{\text{RAS}}$ precharge time (self refresh)	$t_{\text{RPS}}$	90	-	110	-	ns	
$\overline{\text{CAS}}$ hold time (CBR self refresh)	$t_{\text{CHS}}$	-50	-	-50	-	ns	
$\overline{\text{WE}}$ setup time	$t_{\text{WSR}}$	0	-	0	-	ns	
$\overline{\text{WE}}$ hold time	$t_{\text{WHR}}$	10	-	10	-	ns	

**Fast Page Mode Cycle**

Parameter	Symbol	VG26 (V) (S) 17400E				Unit	Notes
		-5		-6			
		Min	Max	Min	Max		
Fast page mode cycle time	$t_{\text{PC}}$	35	-	40	-	ns	
Fast page mode $\overline{\text{CAS}}$ Precharge time	$t_{\text{CP}}$	10	-	10	-	ns	
Fast page mode $\overline{\text{RAS}}$ pulse width	$t_{\text{RASP}}$	50	$10^5$	60	$10^5$	ns	20
Access time from $\overline{\text{CAS}}$ precharge	$t_{\text{CPA}}$	-	30	-	35	ns	10,14
$\overline{\text{RAS}}$ hold time from $\overline{\text{CAS}}$ precharge	$t_{\text{CPRH}}$	30	-	35	-	ns	

**Fast Page Mode Read Modify Write Cycle**

Parameter	Symbol	VG26 (V) (S) 17400E				Unit	Notes
		-5		-6			
		Min	Max	Min	Max		
Fast page mode read - modify - write cycle $\overline{\text{CAS}}$ precharge to $\overline{\text{WE}}$ delay time	$t_{\text{CPW}}$	45	-	55	-	ns	11
Fast page mode read - modify - write cycle time	$t_{\text{PRWC}}$	70	-	80	-	ns	

Notes :

1. AC measurements assume  $t_T = 5\text{ns}$ .
2. An initial pause of  $100\ \mu\text{s}$  is required after power up, and it followed by a minimum of eight initialization cycles ( $\overline{\text{RAS}}$ -only refresh cycle or  $\overline{\text{CAS}}$ -before- $\overline{\text{RAS}}$  refresh cycle). If the internal refresh counter is used, a minimum of eight  $\overline{\text{CAS}}$ -before- $\overline{\text{RAS}}$  refresh cycles are required.
3. In delayed write or read-modify-write cycles,  $\overline{\text{OE}}$  must disable output buffer prior to applying data to the device.
4. All the  $V_{CC}$  and  $V_{SS}$  pins shall be supplied with the same voltage.
5.  $t_{\text{RAS}}(\text{min}) = t_{\text{RWD}}(\text{min}) + t_{\text{RWL}}(\text{min}) + t_T$  in read - modify-write cycle.
6.  $t_{\text{CAS}}(\text{min}) = t_{\text{CWD}}(\text{min}) + t_{\text{CWL}}(\text{min}) + t_T$  in read - modify-write cycle.
7.  $t_{\text{ASC}}(\text{min})$ ,  $t_{\text{RCS}}(\text{min})$ ,  $t_{\text{WCS}}(\text{min})$  and  $t_{\text{RPC}}$  are determined by the falling edge of  $\overline{\text{CAS}}$ .
8.  $t_{\text{RCD}}(\text{max})$  is specified as a reference point only, and  $t_{\text{RAC}}(\text{max})$  can be met with the  $t_{\text{RCD}}(\text{max})$  limit. Otherwise,  $t_{\text{RAC}}$  is controlled exclusively by  $t_{\text{CAC}}$  if  $t_{\text{RCD}}$  is greater than the specified  $t_{\text{RCD}}(\text{max})$  limit.
9.  $t_{\text{RAD}}(\text{max})$  is specified as a reference point only, and  $t_{\text{RAC}}(\text{max})$  can be met with the  $t_{\text{RAD}}(\text{max})$  limit. Otherwise,  $t_{\text{RAC}}$  is controlled exclusively by  $t_{\text{AA}}$  if  $t_{\text{RAD}}$  is greater than the specified  $t_{\text{RAD}}(\text{max})$  limit.
10.  $t_{\text{CRP}}$ ,  $t_{\text{CHR}}$ ,  $t_{\text{RCH}}$ ,  $t_{\text{CPA}}$  and  $t_{\text{CPW}}$  are determined by the rising edge of  $\overline{\text{CAS}}$ .
11.  $V_{\text{IH}}(\text{min})$  and  $V_{\text{IL}}(\text{max})$  are reference levels for measuring timing or input signals. Therefore, transition time is measured between  $V_{\text{IH}}$  and  $V_{\text{IL}}$ .
12. Assumes that  $t_{\text{RCD}} \leq t_{\text{RCD}}(\text{max})$  and  $t_{\text{RAD}} \leq t_{\text{RAD}}(\text{max})$ . If  $t_{\text{RCD}}$  or  $t_{\text{RAD}}$  is greater than the maximum recommended value shown in this table,  $t_{\text{RAC}}$  exceeds the value shown.
13. Assumes that  $t_{\text{RCD}} \geq t_{\text{RCD}}(\text{max})$  and  $t_{\text{RAD}} \leq t_{\text{RAD}}(\text{max})$ .
14. Access time is determined by the maximum among  $t_{\text{AA}}$ ,  $t_{\text{CAC}}$ ,  $t_{\text{CPA}}$ .
15. Assumes that  $t_{\text{RCD}} \leq t_{\text{RCD}}(\text{max})$  and  $t_{\text{RAD}} \geq t_{\text{RAD}}(\text{max})$ .
16. Either  $t_{\text{RCH}}$  or  $t_{\text{RRH}}$  must be satisfied for a read cycle.
17.  $t_{\text{OFF}}(\text{max})$  and  $t_{\text{OEZ}}(\text{max})$  define the time at which the output achieves the open circuit condition (high impedance).
18.  $t_{\text{WCS}}$ ,  $t_{\text{RWD}}$ ,  $t_{\text{CWD}}$ , and  $t_{\text{AWD}}$  are not restrictive operating parameters. They are included in the data sheet as electrical characteristics only. If  $t_{\text{WCS}} \geq t_{\text{WCS}}(\text{min})$ , the cycle is an early write cycle and the data output will remain open circuit (high impedance) throughout the entire cycle. If  $t_{\text{RWD}} \geq t_{\text{RWD}}(\text{min})$ ,  $t_{\text{CWD}} \geq t_{\text{CWD}}(\text{min})$ ,  $t_{\text{AWD}} \geq t_{\text{AWD}}(\text{min})$ , and  $t_{\text{CPW}} \geq t_{\text{CPW}}(\text{min})$ , the cycle is a read-modify-write and the data output will contain data read from the selected cell. If neither of the above sets of conditions is satisfied, the condition of the data output (at access time) is indeterminate.
19. These parameters are referenced to  $\overline{\text{CAS}}$  in an early write cycle and to  $\overline{\text{WE}}$  edge in a delayed write or a read-modify-write cycle.
20.  $t_{\text{RASP}}$  defines  $\overline{\text{RAS}}$  pulse width in Fast page mode cycles.

Timing Waveforms  
• Read Cycle

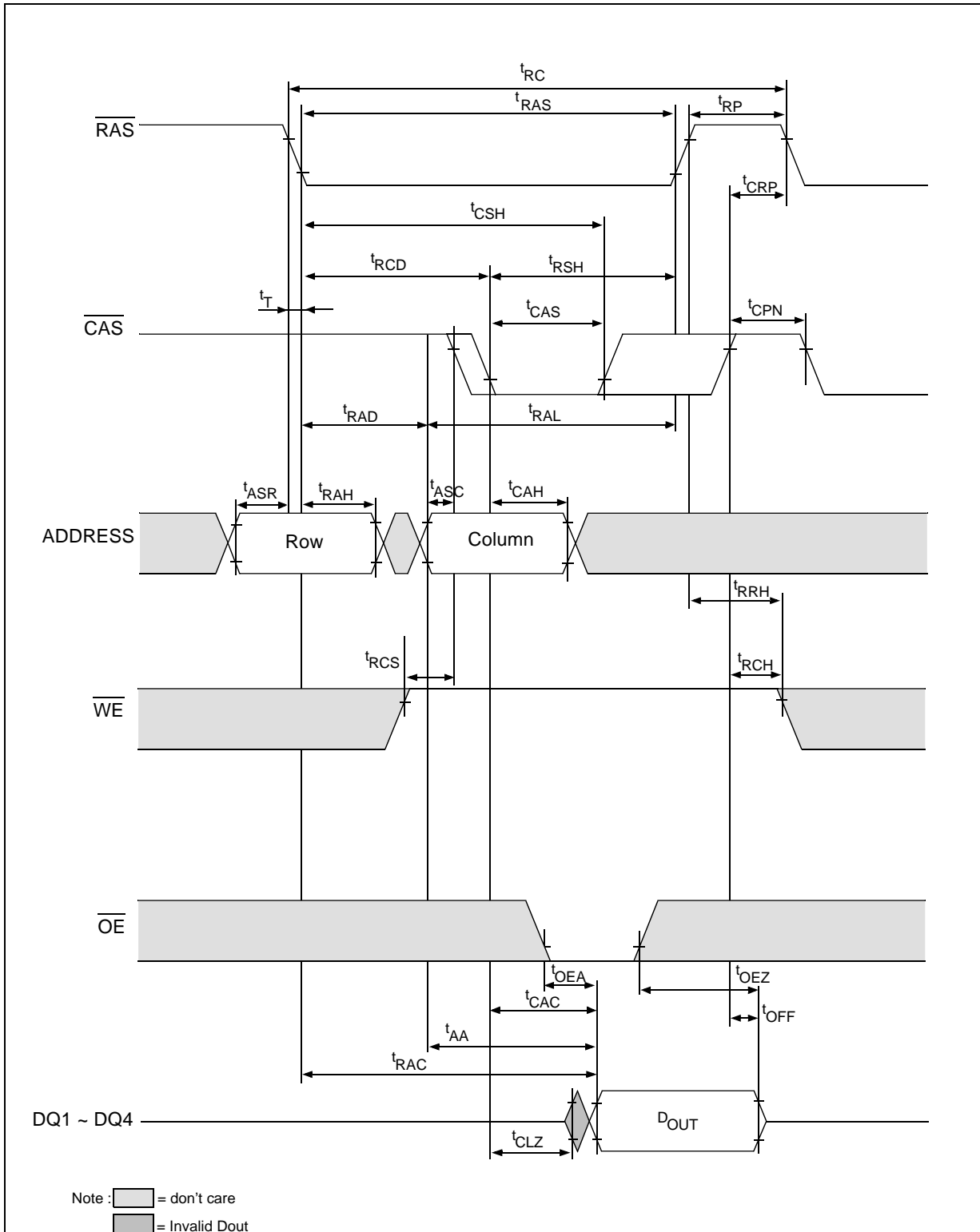

•Early Write Cycle

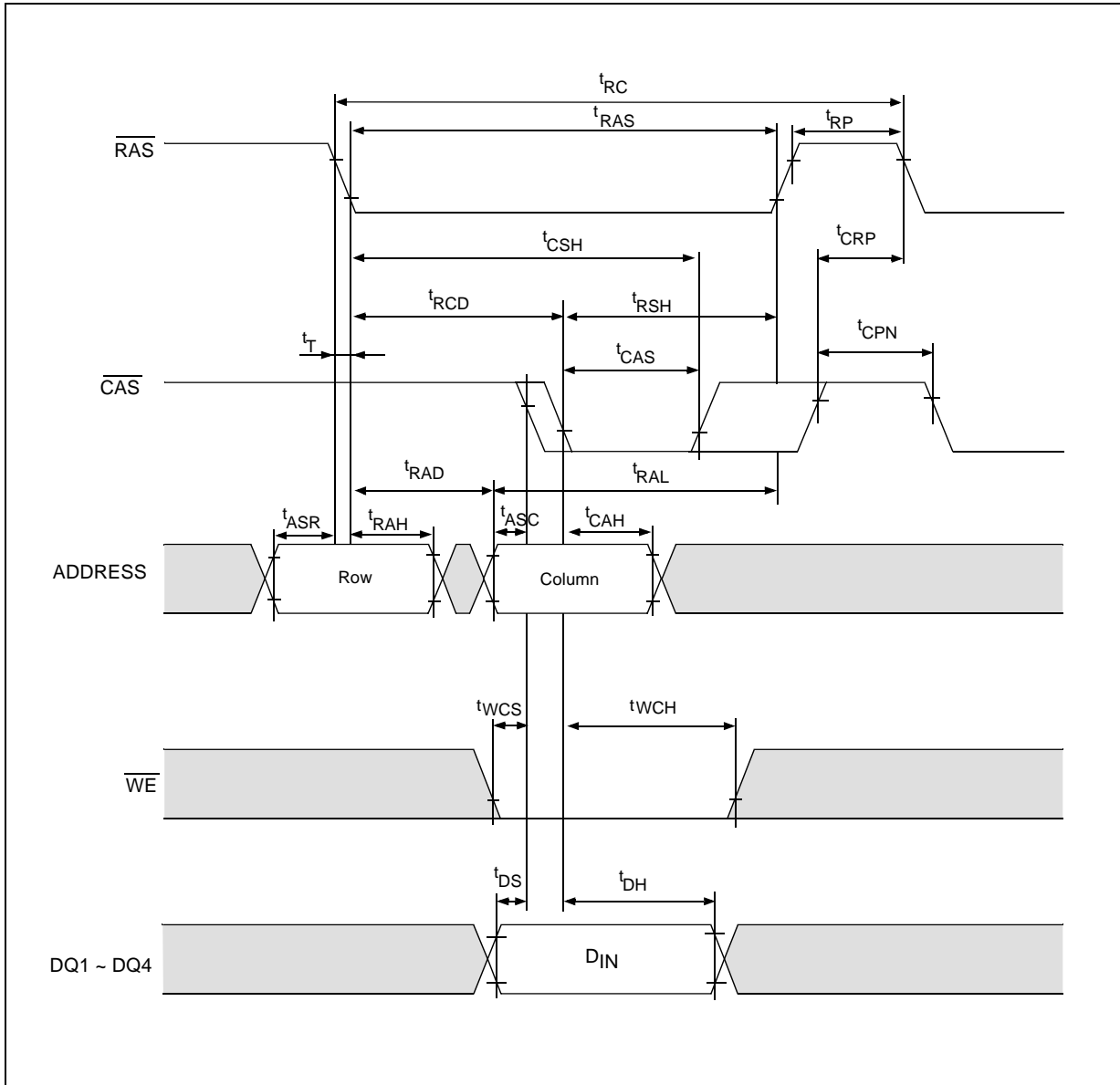

• Delayed Write Cycle

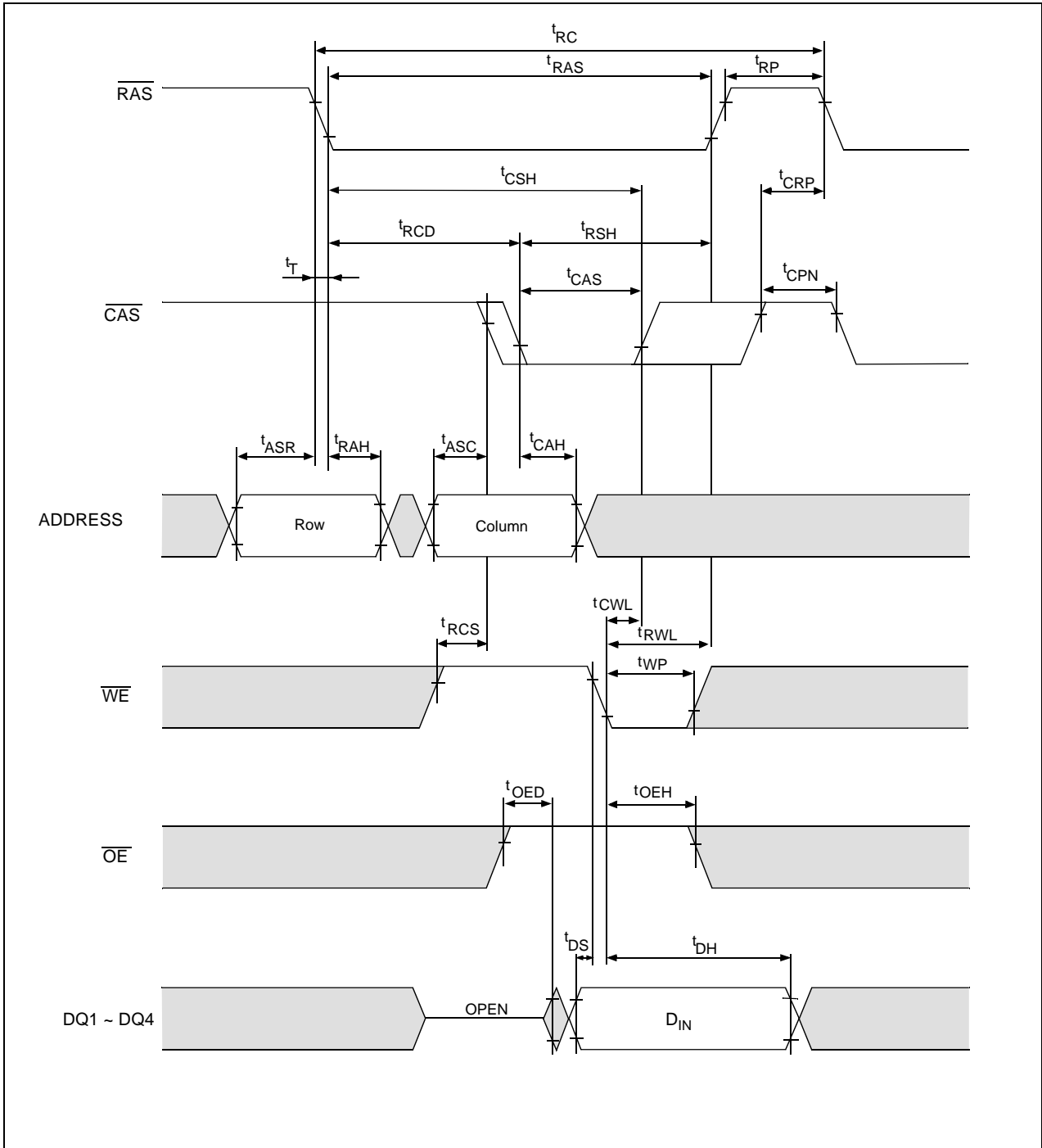



• Read - Modify - Write Cycle

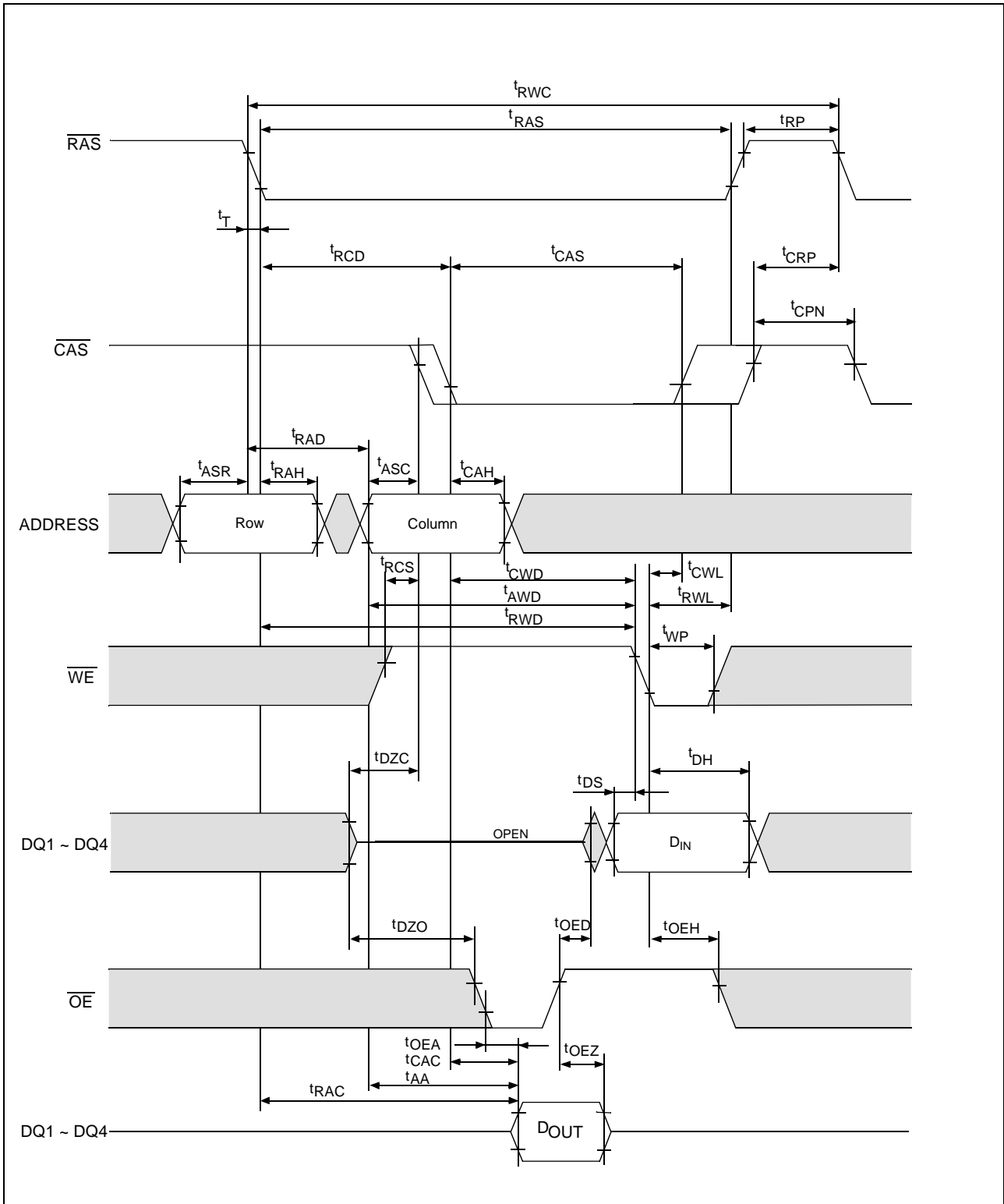

• Fast Page Mode Read Cycle

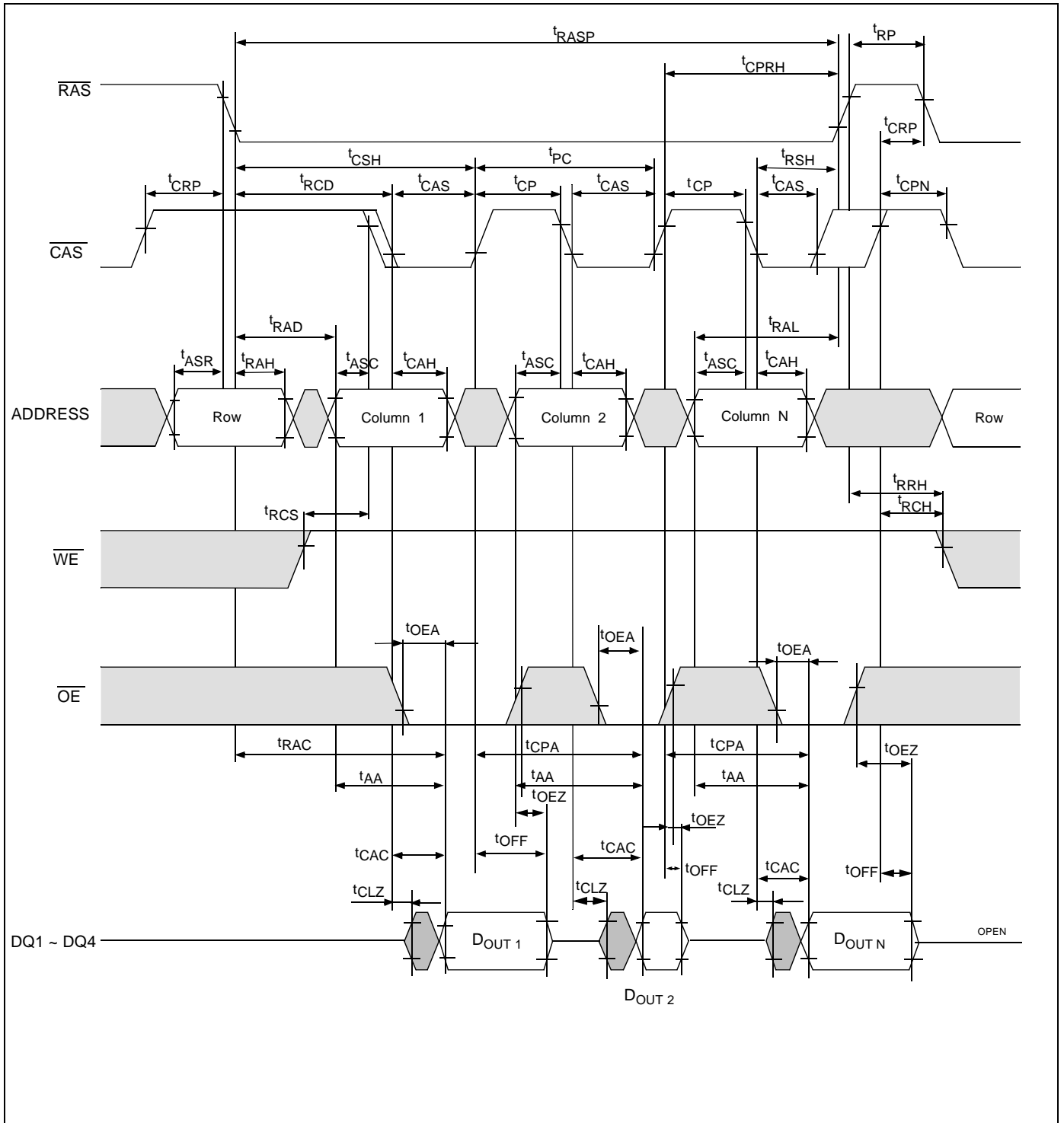

• Fast Page Mode Early Write Cycle

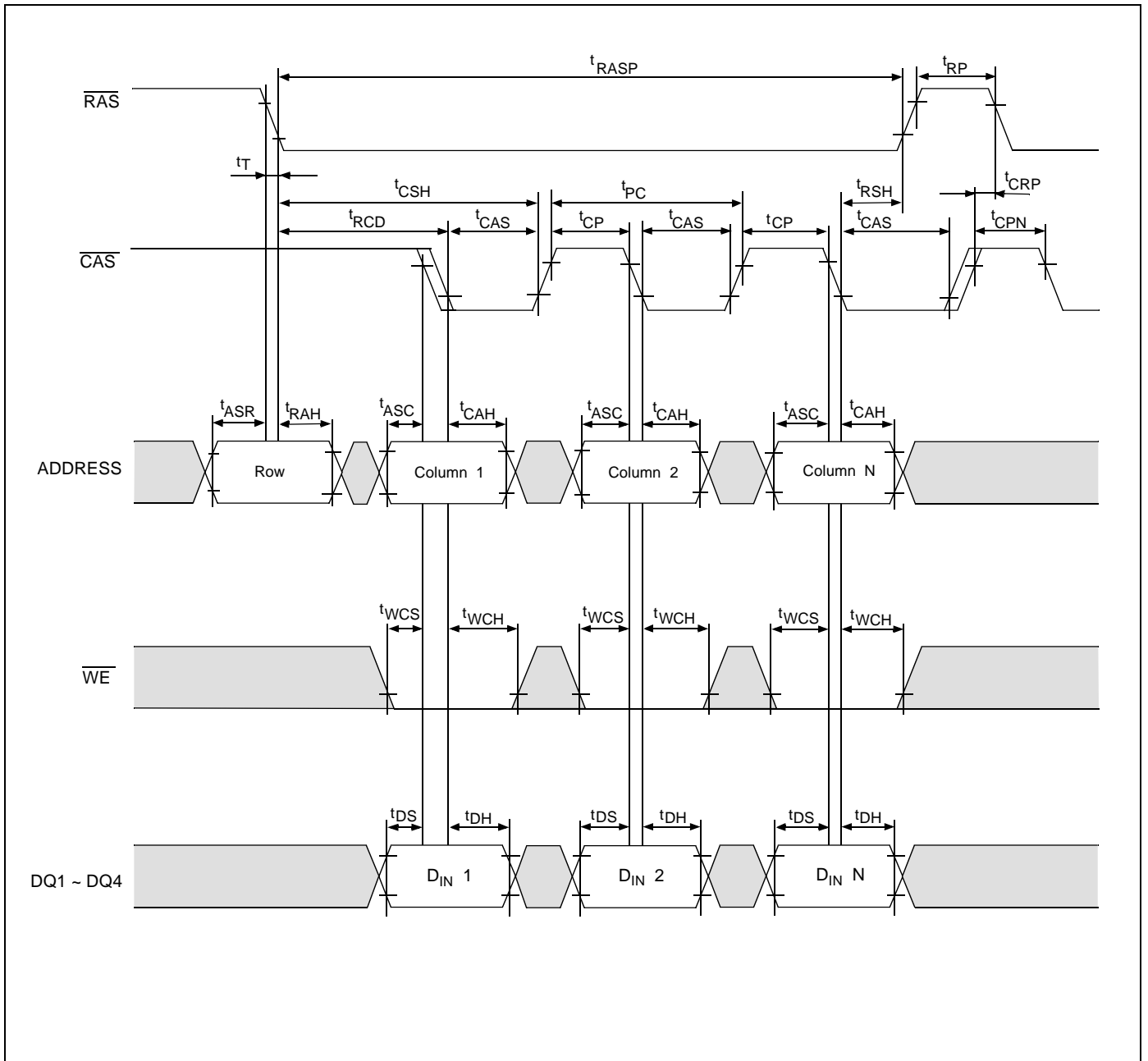

• Fast Page Mode Delayed Write Cycle

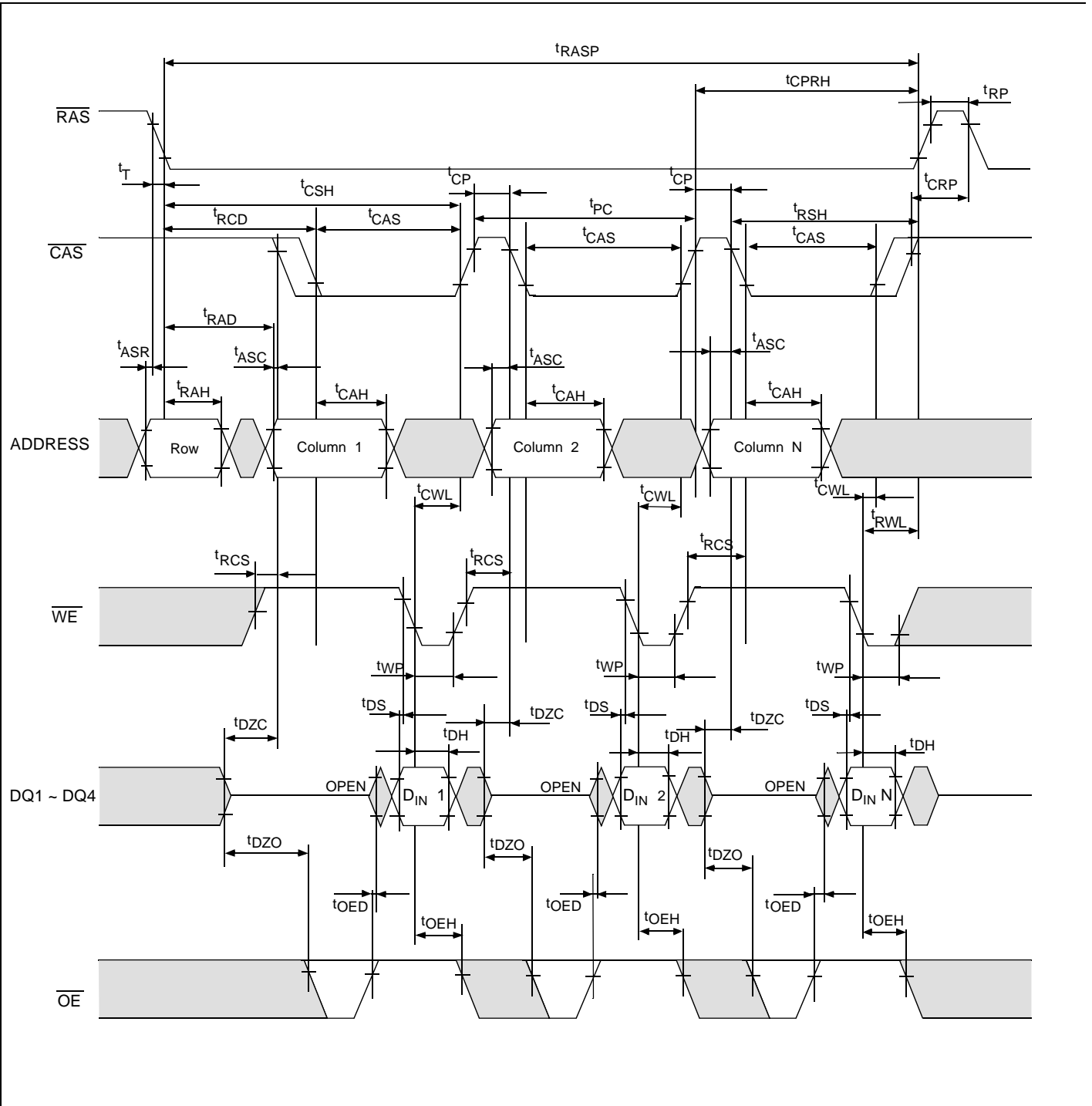

• Fast Page Mode Read - Modify - Write Cycle

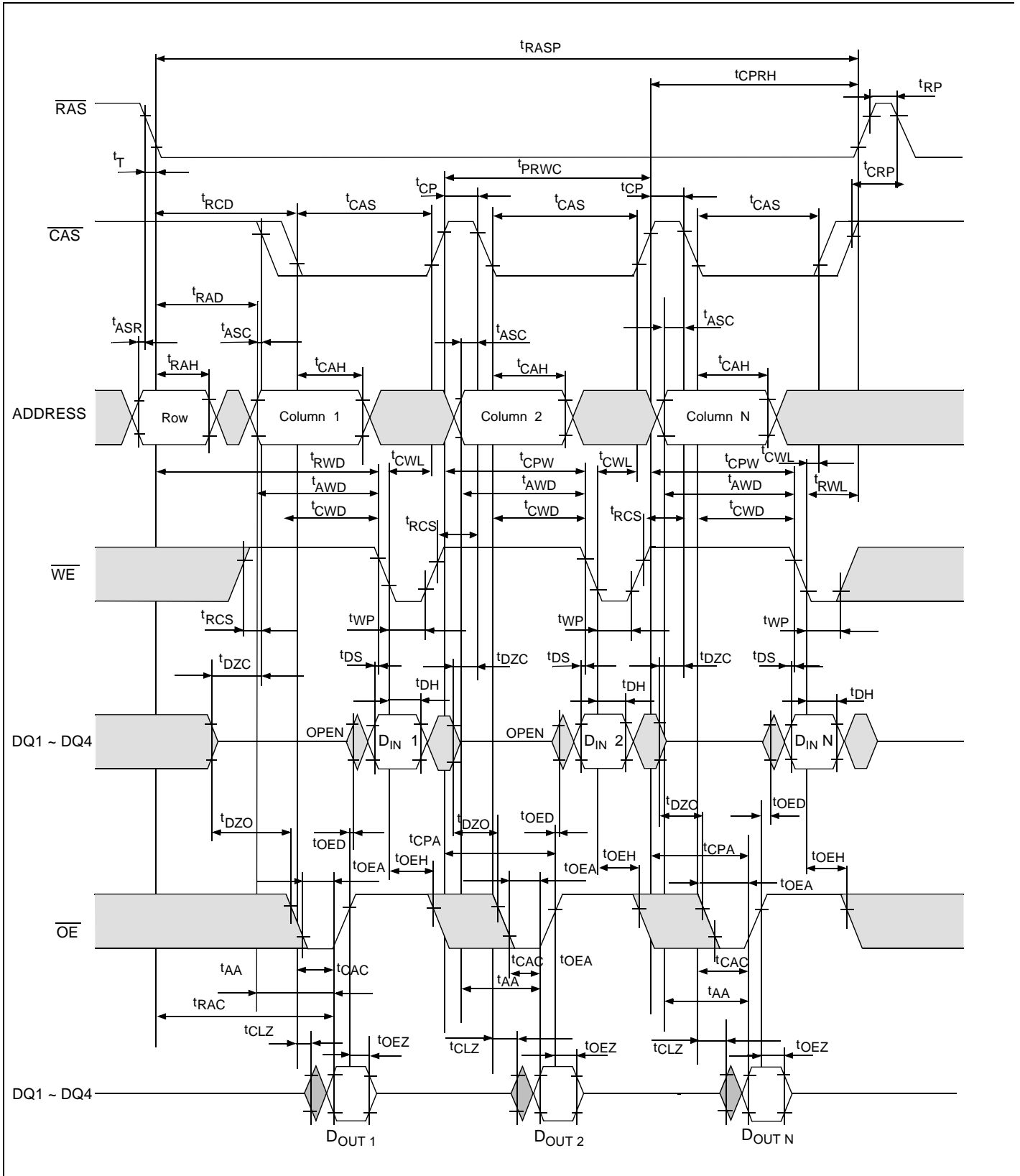

**RAS - Only Refresh Cycle**

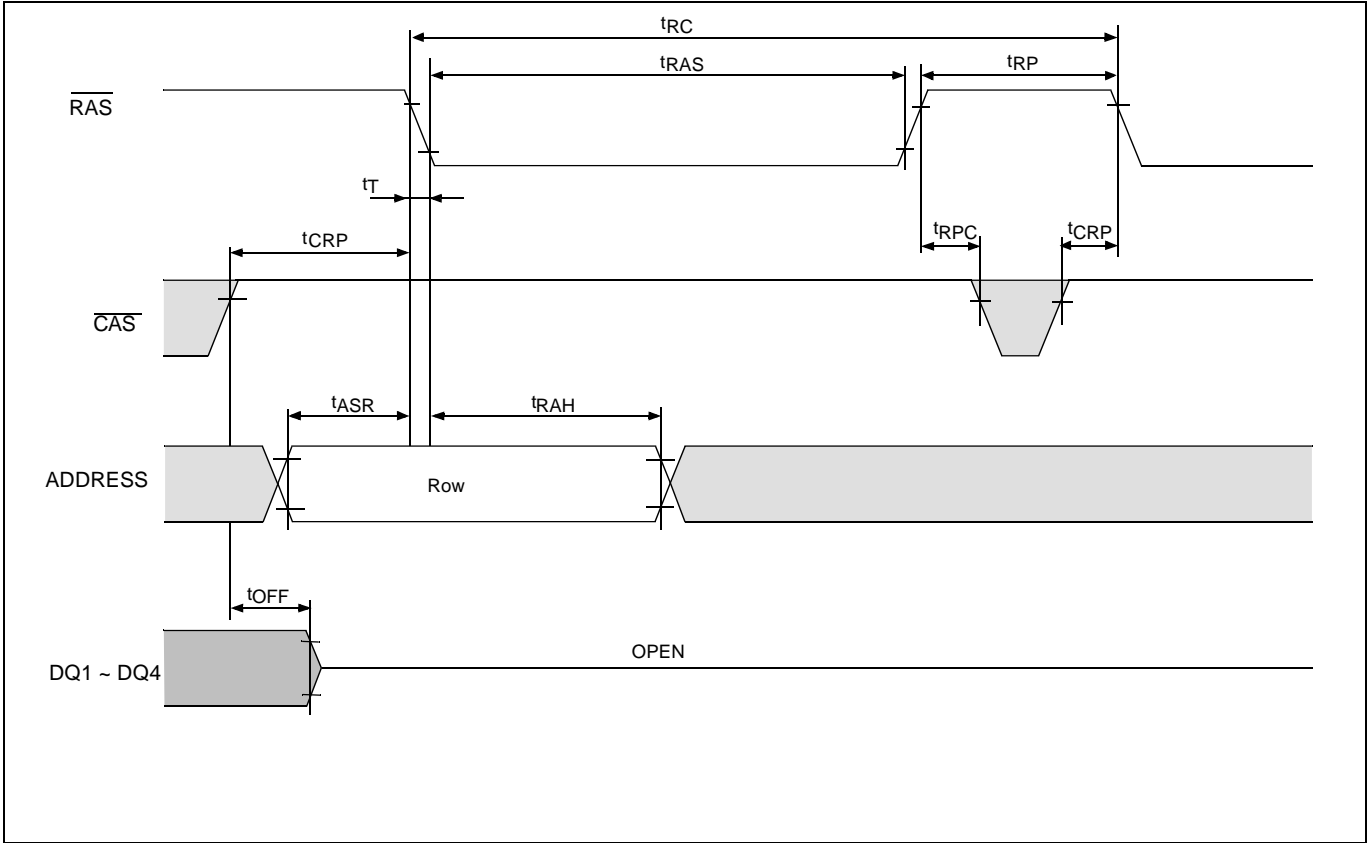

**CAS - Before - RAS Refresh Cycle**

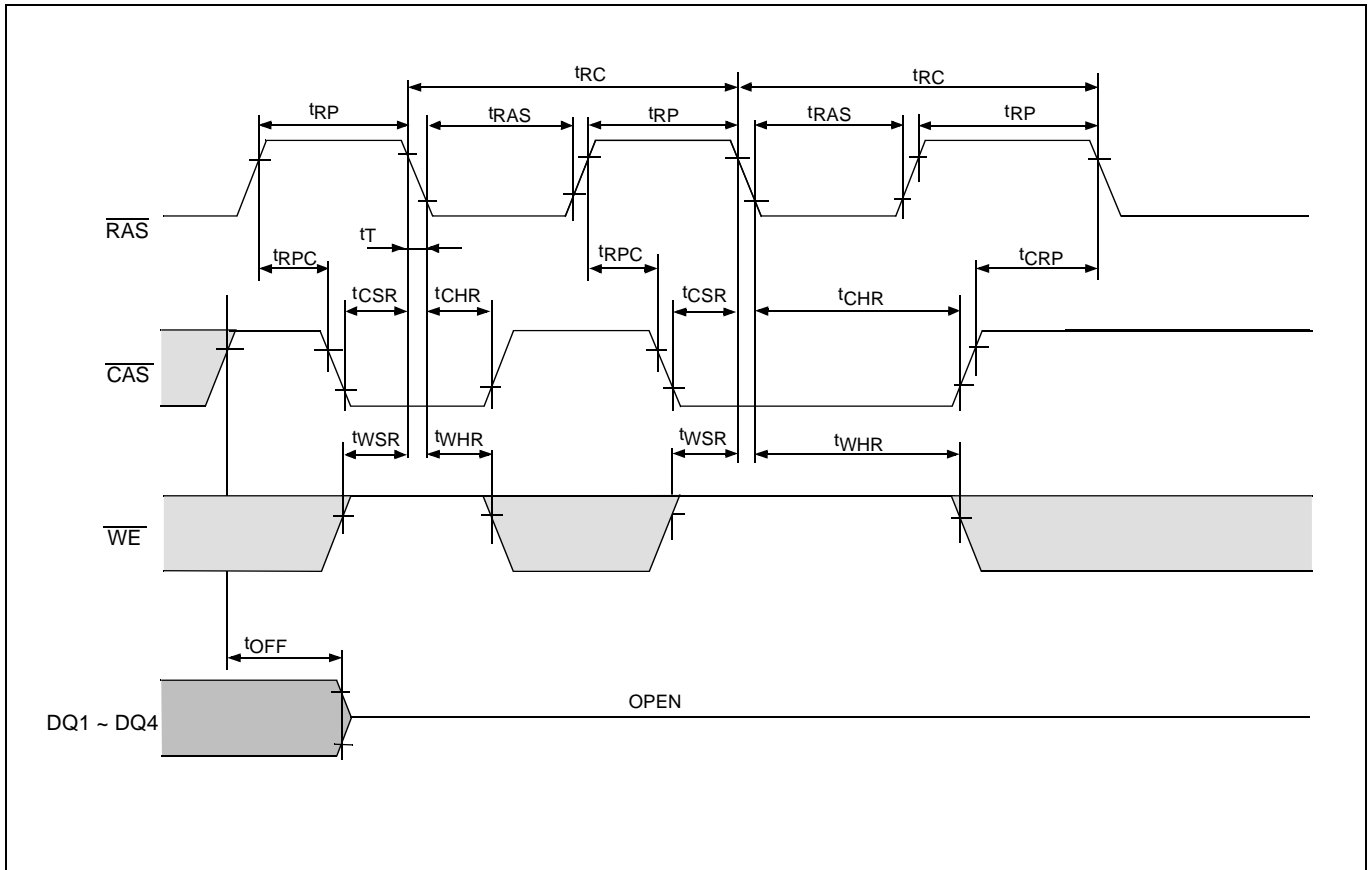

CBR Self - Refresh Cycle ( S - Version Only )

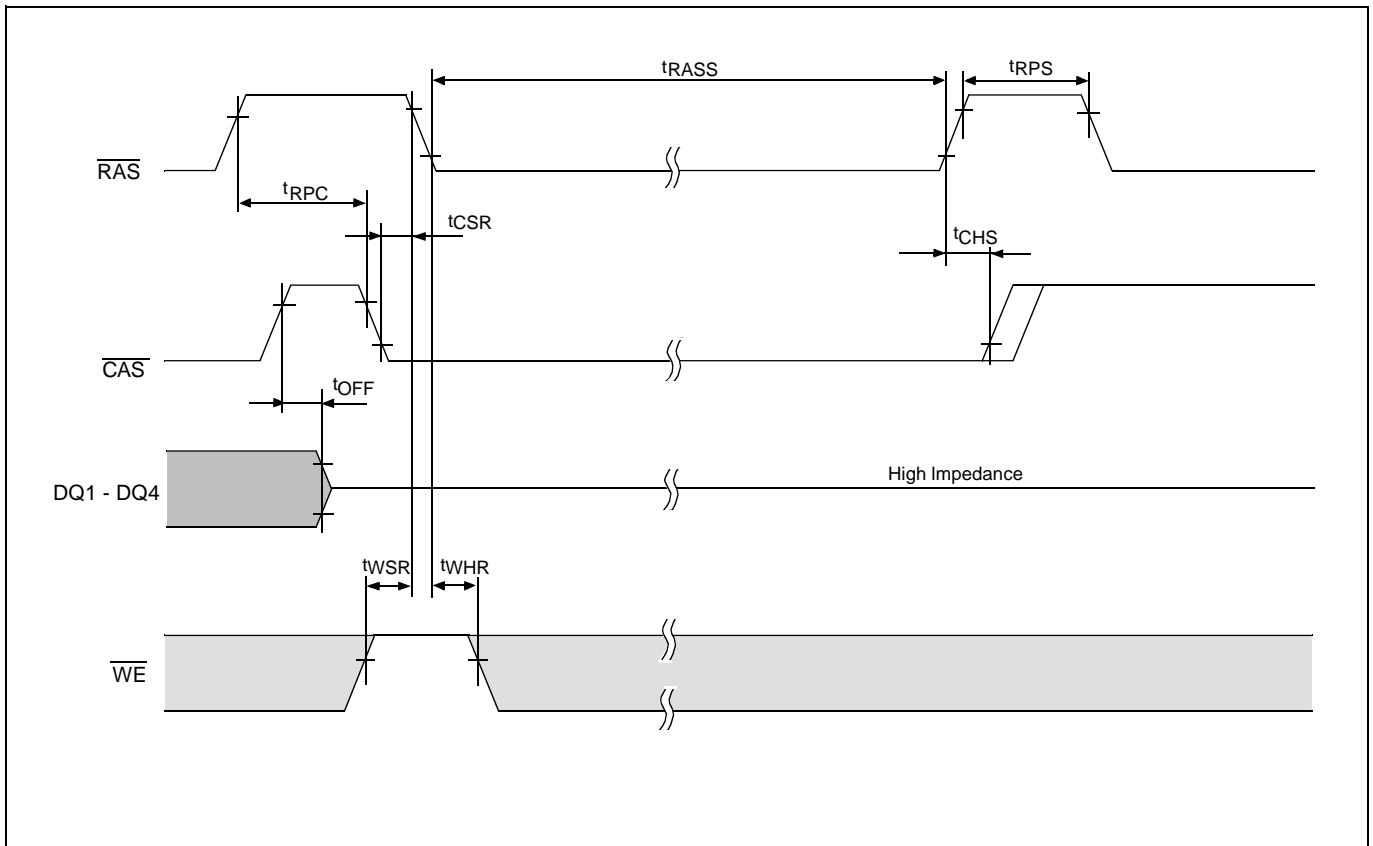

• Hidden Refresh Cycle

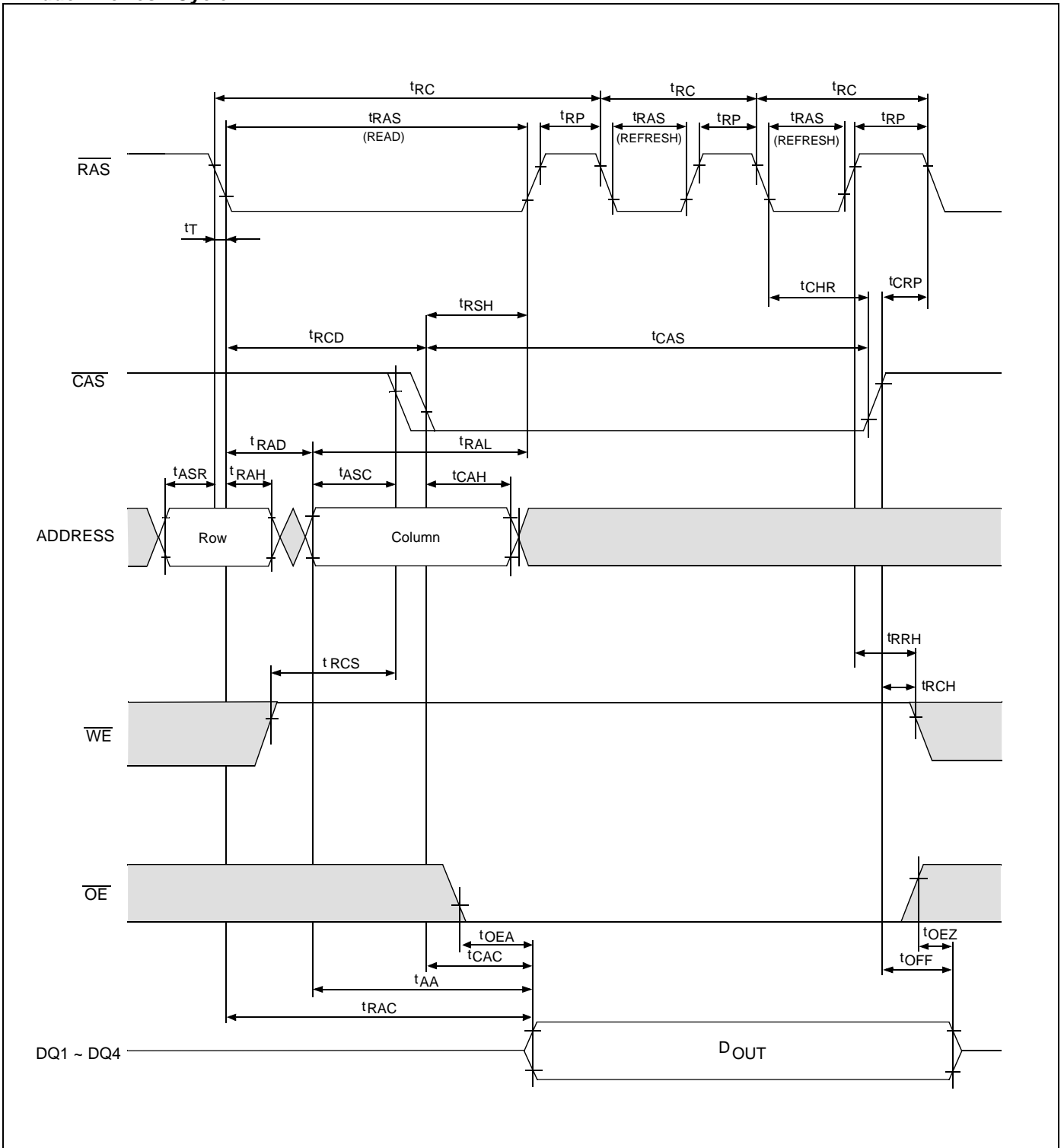



**Ordering information**

Part Number	Access Time	Package
VG26 (V) (S) 17400EJ - 5	50 ns	300mil 26/24 - Pin
VG26 (V) (S) 17400EJ - 6	60 ns	Plastic SOJ

**VG26 (V) (S) 17400EJ - 5**

- VG     ➔     • VIS Memory Product
- 26     ➔     • Technology
- V      ➔     • 3.3V version
- S      ➔     • Self refresh
- 17400 ➔     • Device Type and Configuration
- E      ➔     • Revision
- J      ➔     • Package Type (J : SOJ , T : TSOJ II)
- 5      ➔     • Speed (5 : 50 ns, 6 : 60 ns)

**Packaging information**

- 300 mil, 26/24-Pin Plastic SOJ

