

**Description**

The device is CMOS Synchronous Dynamic RAM organized as 8,388,608 - word x 4 -bit x 4 - bank, 4,194,304 - word x 8 - bit x 4 - bank, or 2,097,152 - word x 16 - bit x 4 - bank. These various organizations provide wide choice for different applications. It is designed with the state-of-the-art technology to meet standard PC100 or high speed PC133 requirement. Four internal independent banks greatly increase the performance efficiency. It is packaged in JEDEC standard pinout and standard plastic 54-pin TSOP package.

**Features**

- Single 3.3V (  $\pm 0.3V$  ) power supply
- High speed clock cycle time : 7.5ns/10ns
- Fully synchronous with all signals referenced to a positive clock edge
- Programmable  $\overline{\text{CAS}}$  latency (2,3)
- Programmable burst length (1,2,4,8,& Full page)
- Programmable wrap sequence (Sequential/Interleave)
- Automatic precharge and controlled precharge
- Auto refresh and self refresh modes
- Quad Internal banks controlled by BA0 & BA1 (Bank select)
- Each Bank can be operated simultaneously and independently
- I/O level : LVTTTL compatible
- Random column access in every cycle
- x4, x8, x16 organization
- Input/Output controlled by DQM ( LDQM, UDQM )
- 4,096 refresh cycles/64ms
- Burst termination by burst stop and precharge command
- Burst read/single write option

The information shown is subject to change without notice.

Pin Configuration

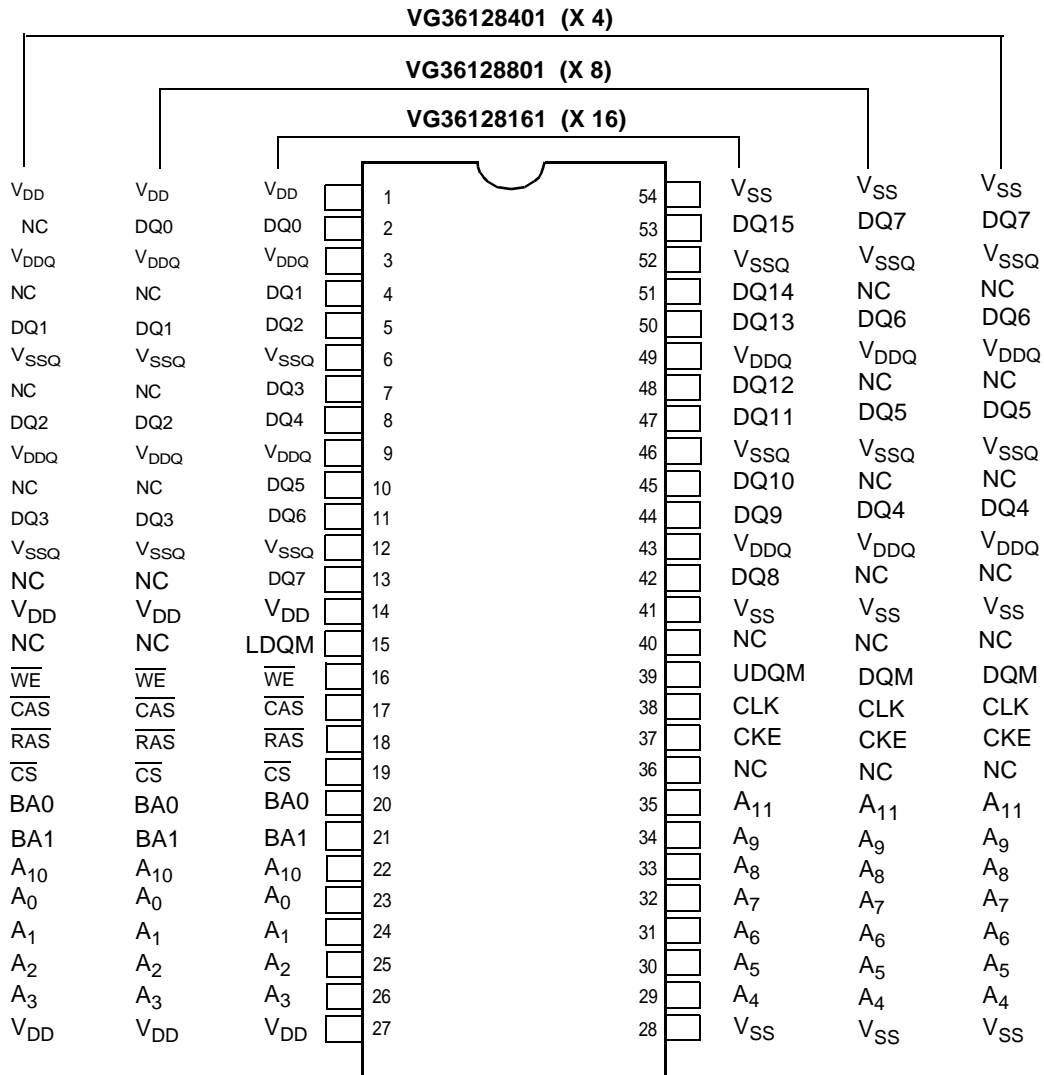

Pin Description

VG36128801/VG36128161

Pin Name	Function	Pin Name	Function
A <sub>0</sub> - A <sub>11</sub> BA0, BA1	Address inputs Bank select	DQM, LDQM, UDQM,	Upper DQ Mask enable, Lower DQ Mask enable
DQ <sub>0</sub> ~ DQ <sub>15</sub>	Data - in/data - out	CLK	Clock input
$\overline{RAS}$	Row address strobe	CKE	Clock enable
$\overline{CAS}$	Column address strobe	$\overline{CS}$	Chip select
$\overline{WE}$	Write enable	V <sub>DDQ</sub>	Supply voltage for DQ
V <sub>SS</sub>	Ground	V <sub>SSQ</sub>	Ground for DQ
V <sub>DD</sub>	Power (+ 3.3V)		

Block Diagram

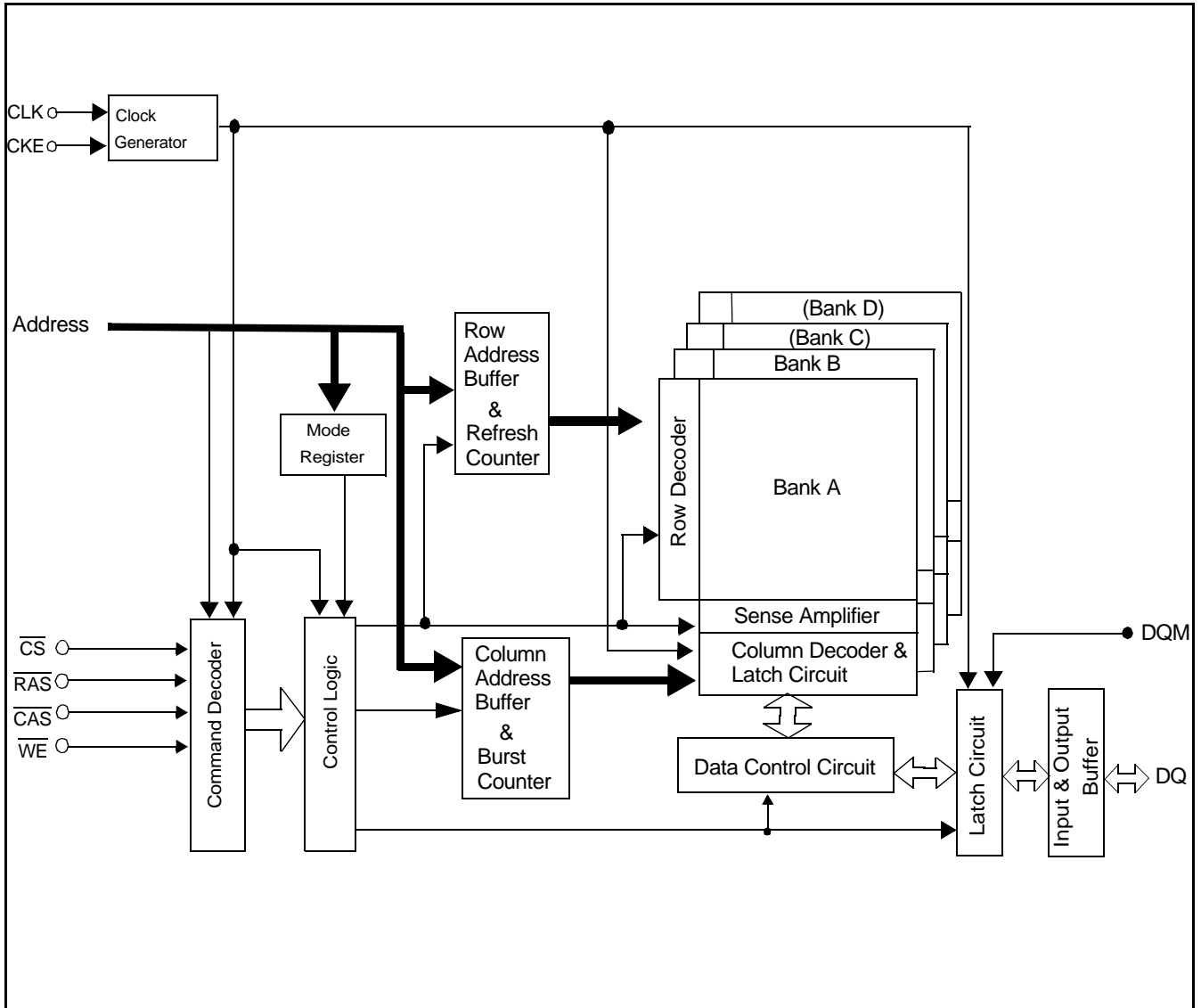

**Absolute Maximum D.C. Ratings**

Parameter	Symbol	Value	Unit
Voltage on any pin relative to Vss	$V_{IN}, V_{OUT}$	-0.5 to + 4.6	V
Supply voltage relative to Vss	$V_{DD}, V_{DDQ}$	-0.5 to + 4.6	V
Short circuit output current	$I_{OUT}$	50	mA
Power dissipation	$P_D$	1.0	W
Operating temperature	$T_{OPT}$	0 to + 70	°C
Storage temperature	$T_{STG}$	-55 to + 125	°C

**Caution:** Exposing the device to stress above those listed in Absolute Maximum Ratings could cause permanent damage. The device is not meant to be operated under conditions outside the limits described in the operational section of this specification. Exposure to Absolute Maximum Rating conditions for extended periods may affect device reliability.

**Maximum A.C. Operating Requirements for LVTTTL Compatible**

Parameter	Symbol	Min	Max	Unit	Notes
Input High Voltage	$V_{IH}$	2.0	$V_{DD} + 0.3$	V	1
Input Low Voltage	$V_{IL}$	-0.3	0.8	V	2

Note: 1. Overshoot limit:  $V_{IH(max)}=V_{DDQ} +2.0V$  with a pulse with  $< 3ns$

2. Undershoot limit:  $V_{IL(min)}=V_{SSQ} -2.0V$  with a pulse with  $< 3ns$  and  $-1.5v$  with a pulse  $< 5ns$

**Recommended DC Operating Conditions for LVTTTL Compatible**

Parameter	Symbol	Min	Typ	Max	Unit
Supply Voltage	$V_{DD}, V_{DDQ}$	3.0	3.3	3.6	V
Input High Voltage, all inputs	$V_{IH}$	2.0	⌀	$V_{DD} + 0.3$	V
Input Low Voltage, all inputs	$V_{IL}$	-0.3	⌀	0.8	V

**Capacitance**

( $T_a=25^{\circ}C, f = 1MHz$ )

Parameter	Symbol	Min	Max	Unit	Notes
Input capacitance (CLK)	$C_{11}$	2.5	4	pF	1
Input capacitance (all input pins except data pins.)	$C_{12}$	2.5	5	pF	1
Data input/output capacitance	$C_{I/O}$	4.0	6.5	pF	1

**Notes :** 1. Capacitance measured with effective capacitance measuring method.

DC Characteristics (Recommended Operating Conditions unless otherwise noted)

Parameter	Symbol	Test Conditions	-75		-8H		Unit	Notes
			Min	Max	Min	Max		
Operating current	I <sub>CC1</sub>	Burst length = 1 One bank active t <sub>RC</sub> ≥ t <sub>RC(MIN.)</sub> , I <sub>O</sub> = 0mA	x4	120		100	mA	1
			x8	125		105		
			x16	135		115		
Precharge standby current in Power down mode	I <sub>CC2P</sub>	CKE ≤ V <sub>IL(MAX.)</sub> t <sub>CK</sub> = min.		2		2	mA	
	I <sub>CC2PS</sub>	CKE ≤ V <sub>IL(MAX.)</sub> t <sub>CK</sub> = ∞		2		2		
Precharge standby current in Nonpower down mode	I <sub>CC2N</sub>	CKE ≥ V <sub>IH(MIN.)</sub> t <sub>CK</sub> = min. CS ≥ V <sub>IH(MIN.)</sub> Input signals are changed one time during 2 CLK cycles.		20		20	mA	
	I <sub>CC2NS</sub>	CKE ≥ V <sub>IH(MIN.)</sub> t <sub>CK</sub> = ∞ CLK ≤ V <sub>IL(MAX.)</sub> Input signals are stable.		7		7		
Active standby current in Power down mode	I <sub>CC3P</sub>	CKE ≤ V <sub>IL(MAX.)</sub> t <sub>CK</sub> = min.		7		7	mA	
	I <sub>CC3PS</sub>	CKE ≤ V <sub>IL(MAX.)</sub> t <sub>CK</sub> = ∞		5		5		
Active standby current in Nonpower down mode	I <sub>CC3N</sub>	CKE ≥ V <sub>IH(MIN.)</sub> t <sub>CK</sub> = min. CS ≥ V <sub>IH(MIN.)</sub> Input signals are changed one time during 2CLKs		30		30	mA	
	I <sub>CC3NS</sub>	CKE ≥ V <sub>IH(MIN.)</sub> t <sub>CK</sub> = ∞ CLK ≤ V <sub>IL(MAX.)</sub> Input signals are stable.		20		20		
Operating current (Burst mode)	I <sub>CC4</sub>	t <sub>CK</sub> ≥ t <sub>CK(MIN.)</sub> I <sub>O</sub> = 0mA All banks Active	x4	115		105	mA	2
			x8	130		120		
			x16	160		150		
Refresh current	I <sub>CC5</sub>	t <sub>RC</sub> = 4 x t <sub>RC(MIN.)</sub>		190		190	mA	3
Self refresh Current	I <sub>CC6</sub>	CKE ≤ 0.2V		1		1	mA	
Input leakage current (Inputs)	I <sub>LI</sub>	V <sub>IN</sub> ≥ 0, V <sub>IN</sub> ≤ V <sub>DD(MAX.)</sub> Pins not under test = 0V	-1	1	-1	1	uA	
Input leakage current (I/O pins)	I <sub>LO</sub>	V <sub>OUT</sub> ≥ 0, V <sub>OUT</sub> ≤ V <sub>DD(MAX.)</sub> DQ# in H - Z., Dout Disabled	-1.5	1.5	-1.5	1.5	uA	
Output Low Voltage	V <sub>OL</sub>	I <sub>OL</sub> = 2mA		0.4		0.4	V	4
Output High Voltage	V <sub>OH</sub>	I <sub>OH</sub> = -2mA	2.4		2.4		V	4

Notes : 1. I<sub>CC1</sub> depends on output loading and cycle rates. Specified values are obtained with the output open.

In addition to this, I<sub>CC1</sub> is measured on condition that addresses are changed only one time during t<sub>CK(MIN.)</sub>.

2. I<sub>CC4</sub> depends on output loading and cycle rates. Specified values are obtained with the output open.

In addition to this, I<sub>CC4</sub> is measured on condition that addresses are changed only one time during t<sub>CK(MIN.)</sub>.

3. I<sub>CC5</sub> is measured on condition that addresses are changed only one time during t<sub>CK(MIN.)</sub>.

4. For LVTTTL compatible.

AC Characteristics : ( $T_a = 0$  to  $70^\circ\text{C}$   $V_{DD} = 3.3\text{V} \pm 0.3\text{V}$ ,  $V_{SS} = 0\text{V}$ )

**Test Conditions for LVTTL Compatible :**

AC input Levels ( $V_{IH}/V_{IL}$ )	2.0/0.8V	Input timing reference level/ Output timing reference level	1.4V
Input rise and fall time	1ns	Output load condition	50pF

AC Test Load Circuits (for LVTTL interface) :

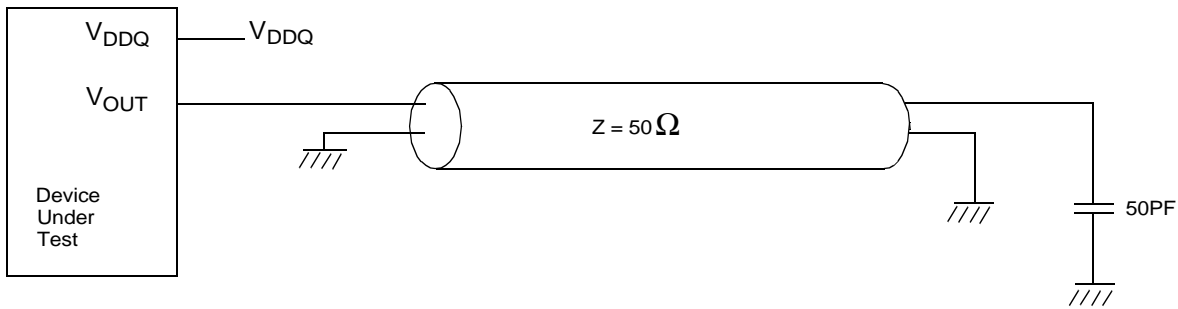



AC Characteristics : (Ta = 0 to 70°C V<sub>DD</sub> = 3.3V±0.3V, V<sub>SS</sub> = 0V)

symbol	A.C. Parameter		-75		-8H		unit	note
			Min.	Max.	Min.	Max.		
t <sub>RC</sub>	Row cycle time		60		70		ns	
t <sub>RCD</sub>	RAS to CAS delay		20		20			
t <sub>RP</sub>	Precharge to refresh/row activate command		15		20			
t <sub>RRD</sub>	Row activate to row activate delay		15		20			
t <sub>RAS</sub>	Row activate to precharge time		37.5	100,000	50	100,000		
t <sub>CK2</sub>	Clock cycle time		CL2	7.5		10	ns	
t <sub>CK3</sub>			CL3	7.5		10		
t <sub>CH</sub>	Clock high time		2.25		3			
t <sub>CL</sub>	Clock low time		2.25		3			
t <sub>AC2</sub>	Access time from CLK (positive edge)		CL2		5	6		
t <sub>AC3</sub>			CL3		5	6		
t <sub>T</sub>	Transition time of CLK (Rise and Fall)		1	10	1	10		
t <sub>CCD</sub>	CAS to CAS Delay time		1		1		CLK	
t <sub>OH</sub>	Data output hold time		2.5		3		ns	
t <sub>LZ</sub>	Data output low impedance		0		0			
t <sub>HZ2</sub>	Data output high impedance		CL2		4	6		9
t <sub>HZ3</sub>			CL3		4	6		
t <sub>IS</sub>	Data/Address/Control Input setup time		1		2			
t <sub>IH</sub>	Data/Address/Control Input hold time		0.5		1			
t <sub>SRX</sub>	Minimum CKE 'High' for Self-Refresh exit		1		1		CLK	
t <sub>PDE</sub>	Power Down Exit set-up time		2		2		ns	
t <sub>RSC</sub>	Mode Register Set Cycle		2		2		CLK	
t <sub>DPL</sub>	Data-in to precharge		2		1		CLK	
t <sub>DAL2</sub>	Data-in to ACT (REF) Command		CL2	2clk+t <sub>RP</sub>		1clk+t <sub>RP</sub>	ns	
t <sub>DAL3</sub>			CL3	2clk+t <sub>RP</sub>		1clk+t <sub>RP</sub>		
t <sub>BDL</sub>	Last data in to burst stop		1		1		CLK	
t <sub>REF</sub>	Refresh time			64		64	ms	

Basic Features and Function Description

1.Simplified State Diagram

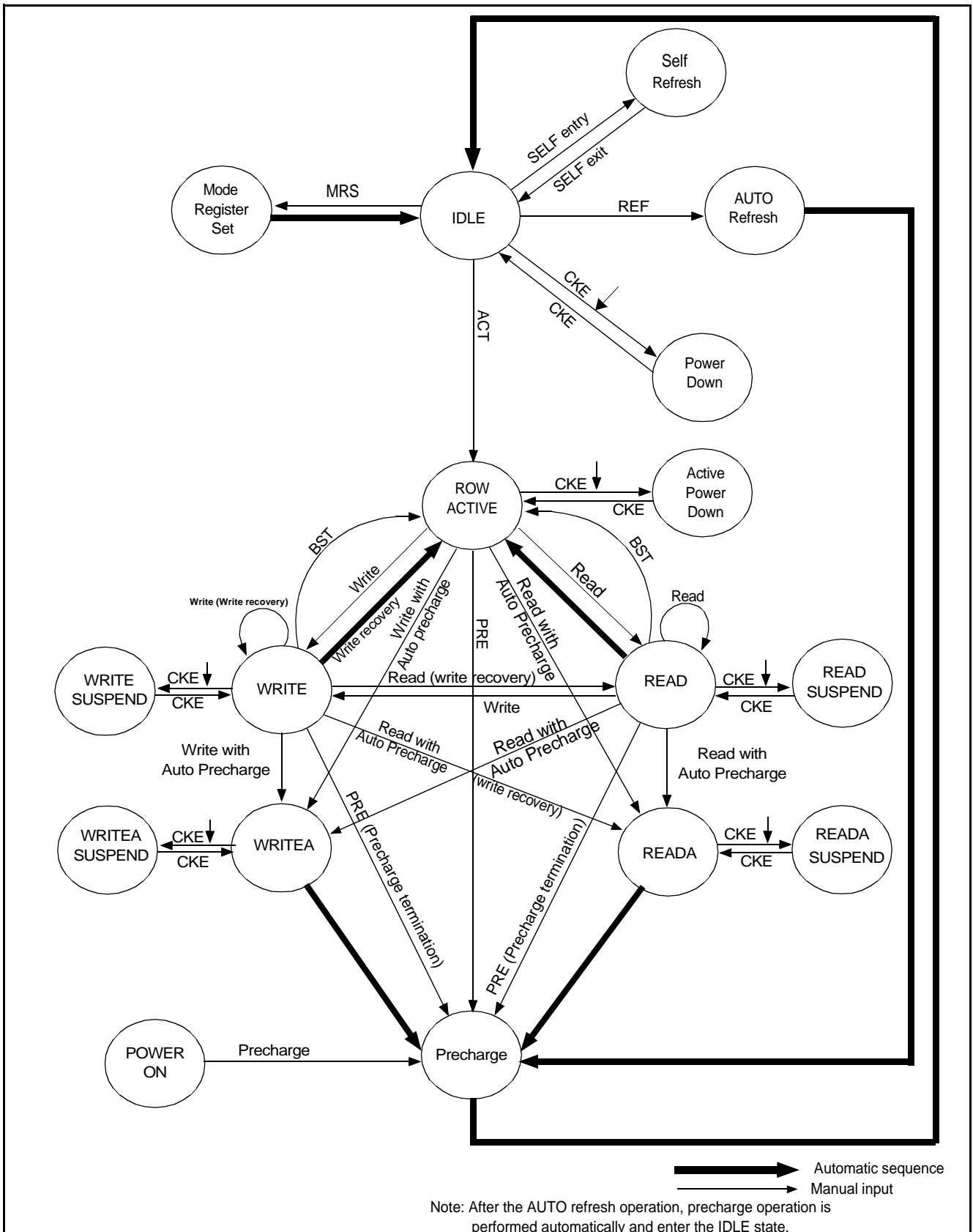



## 2. Truth Table

### 2.1 Command Truth Table

FUNCTION	Symbol	CKE		$\overline{\text{CS}}$	$\overline{\text{RAS}}$	$\overline{\text{CAS}}$	$\overline{\text{WE}}$	BA <sup>(1)</sup>	A10	A11 A9 - A0
		n - 1	n							
Device deselect	DESL	H	X	H	X	X	X	X	X	X
No operation	NOP	H	X	L	H	H	H	X	X	X
Mode register set	MRS	H	X	L	L	L	L	L	L	V
Bank activate	ACT	H	X	L	L	H	H	V	V	V
Read	READ	H	X	L	H	L	H	V	L	V
Read with auto precharge	READA	H	X	L	H	L	H	V	H	V
Write	WRIT	H	X	L	H	L	L	V	L	V
Write with auto precharge	WRITA	H	X	L	H	L	L	V	H	V
Precharge select bank	PRE	H	X	L	L	H	L	V	L	X
Precharge all banks	PALL	H	X	L	L	H	L	X	H	X
Burst stop	BST	H	X	L	H	H	L	X	X	X
CBR (Auto) refresh	REF	H	H	L	L	L	H	X	X	X
Self refresh	SELF	H	L	L	L	L	H	X	X	X

### 2.2 DQM Truth Table

FUNCTION	Symbol	CKE		DQM	
		n - 1	n - 1	U	L
Data write/output enable	ENB	H	X	L	
Data mask/output disable	MASK	H	X	H	
Upper byte write enable/output enable	ENBU	H	X	L	X
Lower byte write enable/output enable	ENBL	H	X	X	L
Upper byte write inhibit/output disable	MASKU	H	X	H	X
Lower byte write inhibit/output disable	MASKL	H	X	X	H

### 2.3 CKE Truth Table

Current State	Function	Symbol	CKE		$\overline{\text{CS}}$	$\overline{\text{RAS}}$	$\overline{\text{CAS}}$	$\overline{\text{WE}}$	Add - ress
			n - 1	n					
Activating	Clock suspend mode entry		H	L	X	X	X	X	X
Any	Clock suspend		L	L	X	X	X	X	X
Clock suspend	Clock suspend mode exit		L	H	X	X	X	X	X
Idle	CBR refresh command	REF	H	H	L	L	L	H	X
Idle	Self refresh entry	SELF	H	L	L	L	L	H	X
Self refresh	Self refresh exit		L	H	L	H	H	H	X
			L	H	H	X	X	X	X
Idle	Power down entry		H	L	X	X	X	X	X
Power down	Power down exit		L	H	X	X	X	X	X

H : High level, L : Low level

X : High or Low level (Dont care), V : Valid Data input

2.4 Operative Command Table Notes 1

(1/3)

Current state	$\overline{CS}$	$\overline{RAS}$	$\overline{CAS}$	$\overline{WE}$	Address	Command	Action	Notes
Idle	H	X	X	X	X	DESL	Nop or Power down	2
	L	H	H	X	X	NOP or BST	Nop or Power down	2
	L	H	L	H	BA, CA, A10	READ/READA	ILLEGAL	3
	L	H	L	L	BA, CA, A10	WRIT/WRITA	ILLEGAL	3
	L	L	H	H	BR, RA	ACT	Row active	
	L	L	H	L	BA, A10	PRE/PALL	Nop	
	L	L	L	H	X	REF/SELF	Refresh or Self refresh	4
	L	L	L	L	Op - Code	MPS	Mode register access	
Row active	H	X	X	X	X	DESL	Nop	
	L	H	H	X	X	NOP or BST	Nop	
	L	H	L	H	BA, CA, A10	READ/READA	Begin read : Determine AP	5
	L	H	L	L	BA, CA, A10	WRIT/WRITA	Begin write : Determine AP	5
	L	L	H	H	BA, RA	ACT	ILLEGAL	3
	L	L	H	L	BA, A10	PRE/PALL	Precharge	6
	L	L	L	H	X	REF/SELF	ILLEGAL	
	L	L	L	L	Op - Code	MRS	ILLEGAL	
Read	H	X	X	X	X	DESL	Continue burst to end → Row active	
	L	H	H	H	X	NOP	Continue burst to end → Row active	
	L	H	H	L	X	BST	Burst end → Row active	
	L	H	L	H	BA, CA, A10	READ/READA	Term burst, new read : Determine AP	7
	L	H	L	L	BA, CA, A10	WRIT/WRITA	Term burst, start write : Determine AP	7,8
	L	L	H	H	BA, RA	ACT	ILLEGAL	3
	L	L	H	L	BA, A10	PRE/PALL	Term burst, precharging	
	L	L	L	H	X	REF/SELF	ILLEGAL	
	L	L	L	L	Op - Code	MRS	ILLEGAL	
Write	H	X	X	X	X	DESL	Continue burst to end → Write recovering	
	L	H	H	H	X	NOP	Continue burst to end → Write recovering	
	L	H	H	L	X	BST	Burst stop → Row active	
	L	H	L	H	BA, CA, A10	READ/READA	Term burst, start read : determine AP	7,8
	L	H	L	L	BA, CA, A10	WRIT/WRITA	Term burst, new write : Determine AP	7
	L	L	H	H	BA, RA	ACT	ILLEGAL	3
	L	L	H	L	BA, A10	PRE/PALL	Term burst, precharging	9
	L	L	L	H	X	REF/SELF	ILLEGAL	
	L	L	L	L	Op - Code	MRS	ILLEGAL	



(2/3)

Current state	CS	RAS	CA	WE	Address	Command	Action	Notes
Read with auto precharge	H	X	X	X	X	DESL	Continue burst to end → Prcharging	
	L	H	H	H	X	NOP	Continue burst to end → Prcharging	
	L	H	H	L	X	BST	Illegal for single bank, but legal for multibanks interleave	
	L	H	L	H	BA, CA, A10	READ/READA	Illegal for single bank, but legal for multibanks interleave	
	L	H	L	L	BA, CA, A10	WRIT/WRITA	ILLEGAL	
	L	L	H	H	BA, RA	ACT	ILLEGAL	3
	L	L	H	L	BA, A10	PRE/PALL	ILLEGAL	3
	L	L	L	H	X	PEF/SELF	ILLEGAL	
	L	L	L	L	Op - Code	MRS	ILLEGAL	
Write with auto precharge	H	X	X	X	X	DESL	Continue burst to end → Write recovering with auto precharge	
	L	H	H	H	X	NOP	Continue burst to end → Write recovering with auto precharge	
	L	H	H	L	X	BST	ILLEGAL	
	L	H	L	H	BA, CA, A10	READ/READA	Illegal for single bank, but legal for multibanks interleave	
	L	H	L	L	BA, CA, A10	WRIT/WRITA	Illegal for single bank, but legal for multibanks interleave	
	L	L	H	H	BA, RA	ACT	ILLEGAL	3
	L	L	H	L	BA, A10	PRE/PALL	ILLEGAL	3
	L	L	L	H	X	PEF/SELF	ILLEGAL	
	L	L	L	L	Op - Code	MRS	ILLEGAL	
precharging	H	X	X	X	X	DESL	Nop → Enter idle after t <sub>RP</sub>	
	L	H	H	H	X	NOP	Nop → Enter idle after t <sub>RP</sub>	
	L	H	H	L	X	BST	Nop → Enter idle after t <sub>RP</sub>	
	L	H	L	H	BA, CA, A10	READ/READA	ILLEGAL	3
	L	H	L	L	BA, CA, A10	WRIT/WRITA	ILLEGAL	3
	L	L	H	H	BA, RA	ACT	ILLEGAL	3
	L	L	H	L	BA, A10	PRE/PALL	Nop → Enter idle after t <sub>RP</sub>	
	L	L	L	H	X	PEF/SELF	ILLEGAL	
	L	L	L	L	Op - Code	MRS	ILLEGAL	
Row activating	H	X	X	X	X	DESL	Nop → Enter row active idle after t <sub>RCD</sub>	
	L	H	H	H	X	NOP	Nop → Enter row active idle after t <sub>RCD</sub>	
	L	H	H	L	X	BST	Nop → Enter row active idle after t <sub>RCD</sub>	
	L	H	L	H	BA, CA, A10	READ/READA	ILLEGAL	3
	L	H	L	L	BA, CA, A10	WRIT/WRITA	ILLEGAL	3
	L	L	H	H	BA, RA	ACT	ILLEGAL	3,9
	L	L	H	L	BA, A10	PRE/PALL	ILLEGAL	3
	L	L	L	H	X	PEF/SELF	ILLEGAL	
	L	L	L	L	Op - Code	MRS	ILLEGAL	

Current state	$\overline{CS}$	$\overline{RAS}$	$\overline{CA}$	$\overline{WE}$	Address	Command	Action	Notes
Write recovering	H	X	X	X	X	DESL	Nop → Enter row active after $t_{DPL}$	
	L	H	H	H	X	NOP	Nop → Enter row active after $t_{DPL}$	
	L	H	H	L	X	BST	Nop → Enter row active after $t_{DPL}$	
	L	H	L	H	BA, CA, A10	READ/READA	Start read, Determine AP	8
	L	H	L	L	BA, CA, A10	WRIT/WRITA	New write, Determine AP	
	L	L	H	H	BA, RA	ACT	ILLEGAL	3
	L	L	H	L	BA, A10	PRE/PALL	ILLEGAL	3
	L	L	L	H	X	PEF/SELF	ILLEGAL	
Write recovering with auto precharge	L	L	L	L	Op - Code	MRS	ILLEGAL	
	H	X	X	X	X	DESL	Nop → Enter precharge after $t_{DPL}$	
	L	H	H	H	X	NOP	Nop → Enter precharge after $t_{DPL}$	
	L	H	H	L	X	BST	Nop → Enter precharge after $t_{DPL}$	
	L	H	L	H	BA, CA, A10	READ/READA	ILLEGAL	3,8
	L	H	L	L	BA, CA, A10	WRIT/WRITA	ILLEGAL	3
	L	L	H	H	BA, RA	ACT	ILLEGAL	3
	L	L	H	L	BA, A10	REF/PALL	ILLEGAL	3
Auto Refreshing	L	L	L	H	X	REF/SELF	ILLEGAL	
	L	L	L	L	Op - Code	MRS	ILLEGAL	
	H	X	X	X	X	DESL	Nop Enter idle after $t_{RC}$	
	L	H	H	X	X	NOP/BST	Nop Enter idle after $t_{RC}$	
	L	H	L	X	X	READ/WRIT	ILLEGAL	
Mode register setting	L	L	H	X	X	ACT/PRE/PALL	ILLEGAL	
	L	L	L	X	X	REF/SELF/MRS	ILLEGAL	
	H	X	X	X	X	DESL	Nop → Enter idle after 2 Clocks	
	L	H	H	H	X	NOP	Nop → Enter idle after 2 Clocks	
	L	H	H	L	X	BST	ILLEGAL	
Mode register setting	L	H	L	X	X	READ/WRITE	ILLEGAL	
	L	L	X	X	X	ACT/PRE/PALL/	ILLEGAL	

Note 1. All entries assume that CKE was active (High level) during the preceding clock cycle.

2. If both banks are idle, and CKE is inactive (Low level), the device will enter Power down mode.

All input buffers except CKE will be disabled.

3. Illegal to bank in specified states; Function may be legal in the bank indicated by Bank Address (BA), depending on the state of that bank.

4. If both banks are idle, and CKE is inactive (Low level), the device will enter Self refresh mode.

All input buffers except CKE will be disabled.

5. Illegal if  $t_{RCD}$  is not satisfied.

6. Illegal if  $t_{RAS}$  is not satisfied.

7. Must satisfy burst interrupt condition.

8. Must satisfy bus contention, bus turn around, and/or write recovery requirements.

9. Must mask preceding data which dont satisfy  $t_{DPL}$ .

10. Illegal if  $t_{RRD}$  is not satisfied.

11. Illegal for single bank, but for multibanks interleave

2.5 Command Truth Table for CKE <sup>Note 1</sup>

Current state	CKE <sub>n-1</sub>	RAS <sub>n</sub>	CS	RAS	CAS	WE	Address	Action	Notes
Self refresh (S.R.)	H	X	X	X	X	X	X	INVALID, CLK (n-1) would exit S.R.	
	L	H	H	X	X	X	X	S.R. Recovery	2
	L	H	L	H	H	X	X	S.R. Recovery	2
	L	H	L	H	L	X	X	ILLEGAL	
	L	H	L	L	X	X	X	ILLEGAL	
	L	L	X	X	X	X	X	Maintain S.R.	
Self refresh recovery	H	H	H	X	X	X	X	Idle after t <sub>RC</sub>	
	H	H	L	H	H	X	X	Idle after t <sub>RC</sub>	
	H	H	L	H	L	X	X	ILLEGAL	
	H	H	L	L	X	X	X	ILLEGAL	
	H	L	H	X	X	X	X	Begin clock suspend next cycle	5
	H	L	L	H	H	X	X	Begin clock suspend next cycle	5
	H	L	L	H	L	X	X	ILLEGAL	
	H	L	L	L	X	X	X	ILLEGAL	
	L	H	X	X	X	X	X	Exit clock suspend next cycle	2
	L	L	X	X	X	X	X	Maintain clock suspend	
Power down (P.D.)	H	X	X	X	X	X		INVALID, CLK(n-1) would exit P.D.	
	L	H	X	X	X	X	X	EXIT P.D. → Idle	2
	L	L	X	X	X	X	X	Maintain power down mode	
Both banks idle	H	H	H	X	X	X		Refer to operations in Operative Command Table	
	H	H	L	H	X	X		Refer to operations in Operative Command Table	
	H	H	L	L	H	X		Refer to operations in Operative Command Table	
	H	H	L	L	L	H	X	Auto Refresh	
	H	H	L	L	L	L	Op-Code	Refer to operations in Operative Command Table	
	H	L	H	X	X	X		Refer to operations in Operative Command Table	
	H	L	L	H	X	X		Refer to operations in Operative Command Table	
	H	L	L	L	H	X		Refer to operations in Operative Command Table	
	H	L	L	L	L	H	X	Self refresh	3
	H	L	L	L	L	L	Op-Code	Refer to operations in Operative Command Table	
	L	X	X	X	X	X	X	Power down	3
Any state other than listed above	H	H	X	X	X	X	X	Refer to operations in Operative Command Table	
	H	L	X	X	X	X	X	Begin clock suspend next cycle	4
	L	H	X	X	X	X	X	Exit clock suspend next cycle	
	L	L	X	X	X	X	X	Maintain clock suspend	

Note 1. H : Hight level, L : low level, X : High or low level (Don't care)

2. CKE Low to High transition will re-enable CLK and other inputs asynchronously. A minimum setup time must be satisfied before any command other than EXIT.
3. Power down and Self refresh can be entered only from the both banks idle state.
4. Must be legal command as defined in Operative Command Table.
5. Illegal if t<sub>SREX</sub> is not satisfied.

5.Mode Register (Address Input for Mode Set)

13	12	11	10	9	8	7	6	5	4	3	2	1	0
0	0	0	0	0	0	1	Reserved						

JEDEC Standard Test Set

13	12	11	10	9	8	7	6	5	4	3	2	1	0
x	x	x	x	1	0	0	LTMODE	WT	BL				

Burst Read and Single Write (for Write Through Cache)

13	12	11	10	9	8	7	6	5	4	3	2	1	0
x	x	x	x	0	0	0	LTMODE	WT	BL				

Burst Read and Burst Write

X = Dont care

Burst length	Bits2 - 0	WT = 0	WT = 1
	000	1	1
	001	2	2
	010	4	4
	011	8	8
	100	R	R
	101	R	R
	110	R	R
	111	Full page	R

Wrap type	0	Sequential
	1	Interleave

Latency mode	Bits6 - 4	CAS latency
	000	R
	001	R
	010	2
	011	3
	100	R
	101	R
	110	R
	111	R

Remark R : Reserved

### 5.1 Burst Length and Sequence

(Burst of Two)

Starting Address (column address A0, binary)	Sequential Addressing Sequence (decimal)	Interleave Addressing Sequence (decimal)
0	0, 1	0, 1
1	1, 0	1, 0

(Burst of Four)

Starting Address (column address A1 - A0, binary)	Sequential Addressing Sequence (decimal)	Interleave Addressing Sequence (decimal)
00	0, 1, 2, 3	0, 1, 2, 3
01	1, 2, 3, 0	1, 0, 3, 2
10	2, 3, 0, 1	2, 3, 0, 1
11	3, 0, 1, 2	3, 2, 1, 0

(Burst of Eight)

Starting Address (column address A2 - A0, binary)	Sequential Addressing Sequence (decimal)	Interleave Addressing Sequence (decimal)
000	0, 1, 2, 3, 4, 5, 6, 7	0, 1, 2, 3, 4, 5, 6, 7
001	1, 2, 3, 4, 5, 6, 7, 0	1, 0, 3, 2, 5, 4, 7, 6
010	2, 3, 4, 5, 6, 7, 0, 1	2, 3, 0, 1, 6, 7, 4, 5
011	3, 4, 5, 6, 7, 0, 1, 2	3, 2, 1, 0, 7, 6, 5, 4
100	4, 5, 6, 7, 0, 1, 2, 3	4, 5, 6, 7, 0, 1, 2, 3
101	5, 6, 7, 0, 1, 2, 3, 4	5, 4, 7, 6, 1, 0, 3, 2
110	6, 7, 0, 1, 2, 3, 4, 5	6, 7, 4, 5, 2, 3, 0, 1
111	7, 0, 1, 2, 3, 4, 5, 6	7, 6, 5, 4, 3, 2, 1, 0

Full page burst is an extension of the above tables of Sequential Addressing, with the length being 2048 / 1024 / 512 for 32M x 4 / 16M x 8 / 8M X16 devices, respectively.

6 Address Bits of Bank-Select and precharge

6.1 Quad banks controlled by A12 & A13

Row	A0	A1	A2	A3	A4	A5	A6	A7	A8	A9	A10	A11	A12	A13	A12	A13	Result
(Activate command)															0	0	Select Bank A "Activate" command
															0	1	Select Bank B "Activate" command
															1	0	Select Bank C "Activate" command
															1	1	Select Bank D "Activate" command

Row	A0	A1	A2	A3	A4	A5	A6	A7	A8	A9	A10	A11	A12	A13	A10	A12	A13	Result
(Precharge command)															0	0	0	Precharge Bank A
															0	0	1	Precharge Bank B
															0	1	0	Precharge Bank C
															0	1	1	Precharge Bank D
															1	X	X	Precharge All Banks

Col.	A0	A1	A2	A3	A4	A5	A6	A7	A8	A9	A10	A11	A12	A13	A12	A13	Result
(CAS strobes)															0	0	Enables Read/Write commands for Bank A
															0	1	Enables Read/Write commands for Bank B
															1	0	Enables Read/Write commands for Bank C
															1	1	Enables Read/Write commands for Bank D



### 7.Precharge

The precharge command can be asserted anytime after  $t_{RAS(min)}$  is satisfied.

Soon after the precharge command is asserted, the precharge operation is performed and the synchronous DRAM enters the idle state after  $t_{RP(min)}$  is satisfied. The parameter  $t_{RP}$  is the time required to perform the precharge.

The earliest timing in a read cycle that a precharge command can be asserted without losing any data in the burst is as follows.

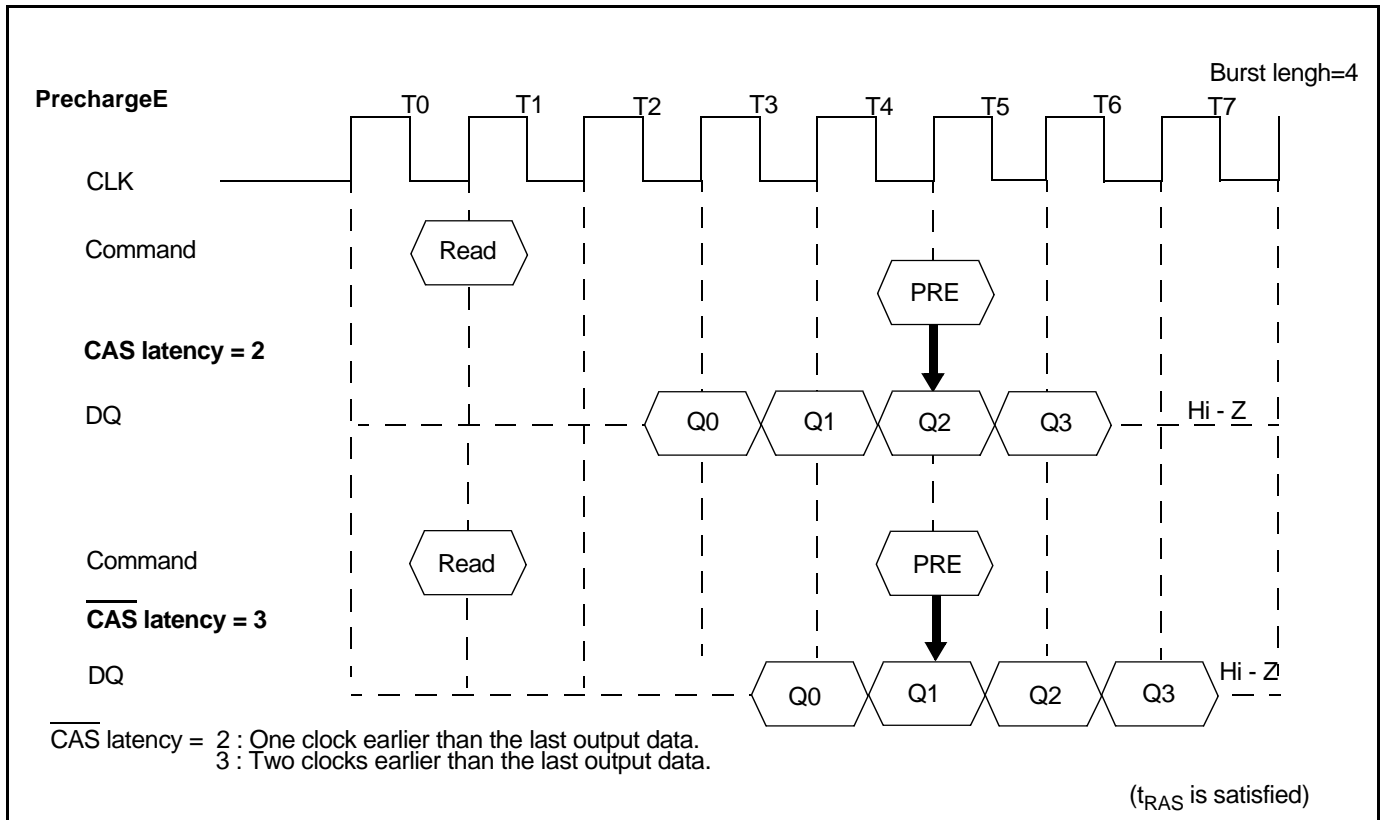

In order to write all data to the memory cell correctly, the asynchronous parameter " $t_{DPL}$ " must be satisfied. The  $t_{DPL(min)}$  specification defines the earliest time that a precharge command can be asserted. The minimum number of clocks can be calculated by dividing  $t_{DPL(min)}$  by the clock cycle time.

In summary, the precharge command can be asserted relative to the reference clock that indicates the last data word is valid. In the following table, minus means clocks before the reference; plus means time after the reference.

CAS latency	Read	Write
2	-1	+ $t_{DPL(min)}$
3	-2	+ $t_{DPL(min)}$

## 8.Auto Precharge

During a read or write command cycle, A10 controls whether auto precharge is selected. If A10 is high in the read or write command (Read with Auto precharge command or Write with Auto precharge command), auto precharge is selected and begins automatically after the burst access.

In the write cycle,  $t_{DAL(min.)}$  must be satisfied before asserting the next activate command to the bank being precharged.

When using auto precharge in the read cycle, knowing when the precharge starts is important because the next activate command to the bank being precharged cannot be executed until the precharge cycle ends. Once auto precharge has started, an activate command to the bank can be asserted after  $t_{RP}$  has been satisfied.

A Read or Write command without auto - precharge can be terminated in the midst of a burst operation. However, a Read or Write command with auto - precharge can not be interrupted by the same bank commands before the entire burst operation is completed. Therefore use of the same bank Read, Write, Precharge or Burst Stop command is prohibited during a read or write cycle with auto - precharge. It should be noted that the device will not respond to the Auto - Precharge command if the device is programmed for full page burst read or write cycles.

The timing when the auto precharge cycle begins depends both on both the  $\overline{CAS}$  latency programmed into the mode register and whether the cycle is read or write.

### 8.1 Read with Auto Precharge

During a READA cycle, the auto precharge begins one clock earlier ( $CL = 2$ ) or two clocks earlier ( $CL = 3$ ) than the last word output.

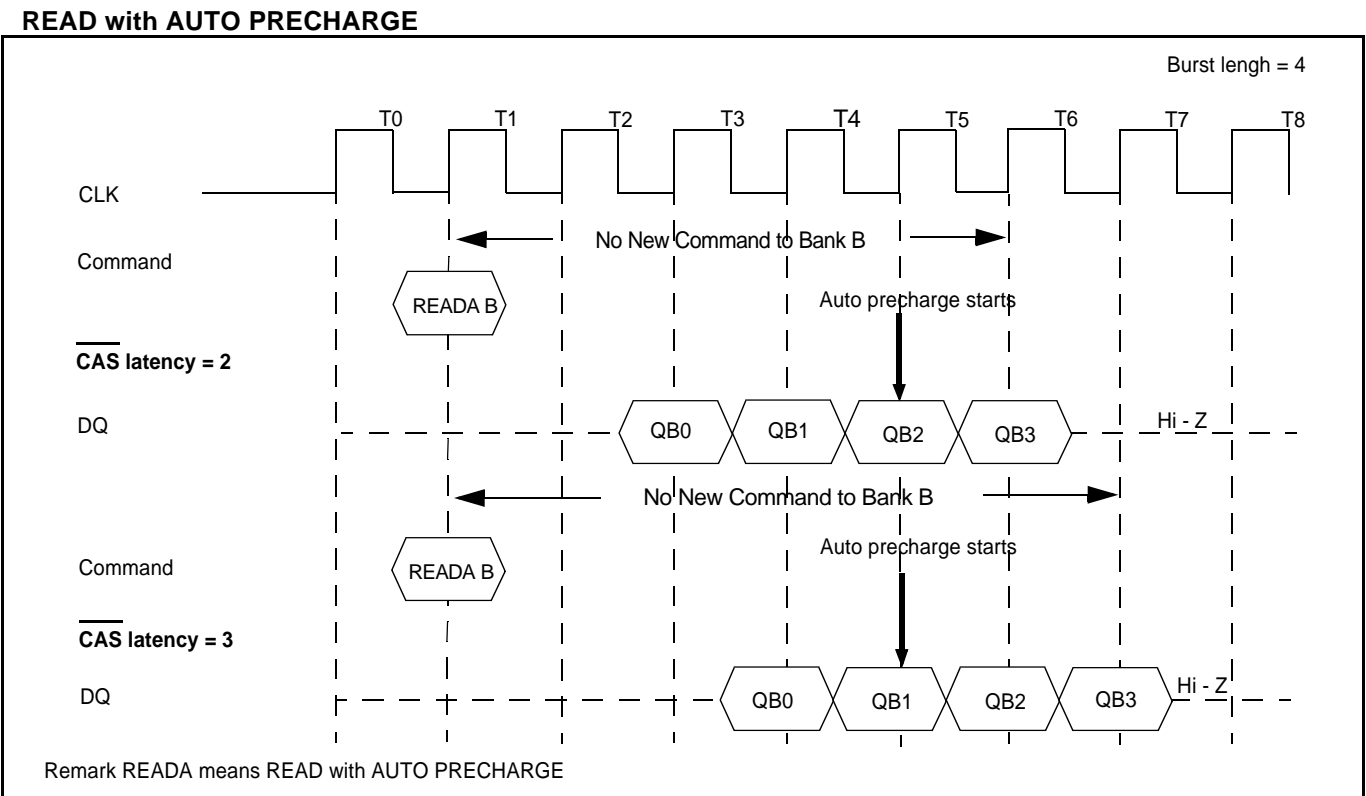

### 8.2 Write with Auto Precharge

During a write cycle, the auto precharge starts at the timing that is equal to the value of  $t_{DPL(min.)}$  after the last data word input to the device.

#### WRITE with AUTO PRECHARGE

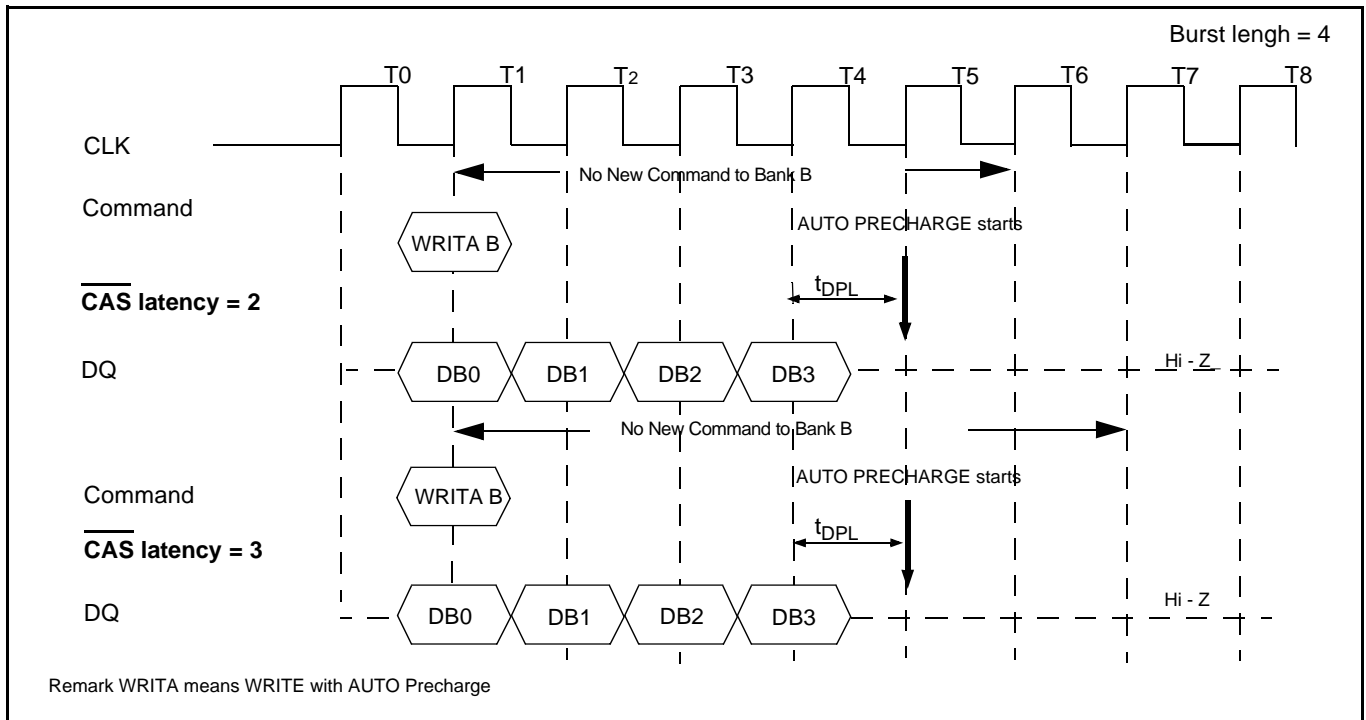

In summary, the auto precharge cycle begins relative to a reference clock that indicates the last data word is valid.

In the table below, minus means clocks before the reference; plus means clocks after the reference.

CAS latency	Read	Write
2	-1	+ $t_{DPL(min.)}$
3	-2	+ $t_{DPL(min.)}$

### 8.3 Multibank Operation- Read with Auto Precharge

During a READA cycle interrupted by a Read, Write command of another banks, the auto-precharge scheduled time would not be changed.

#### Multibank Operation

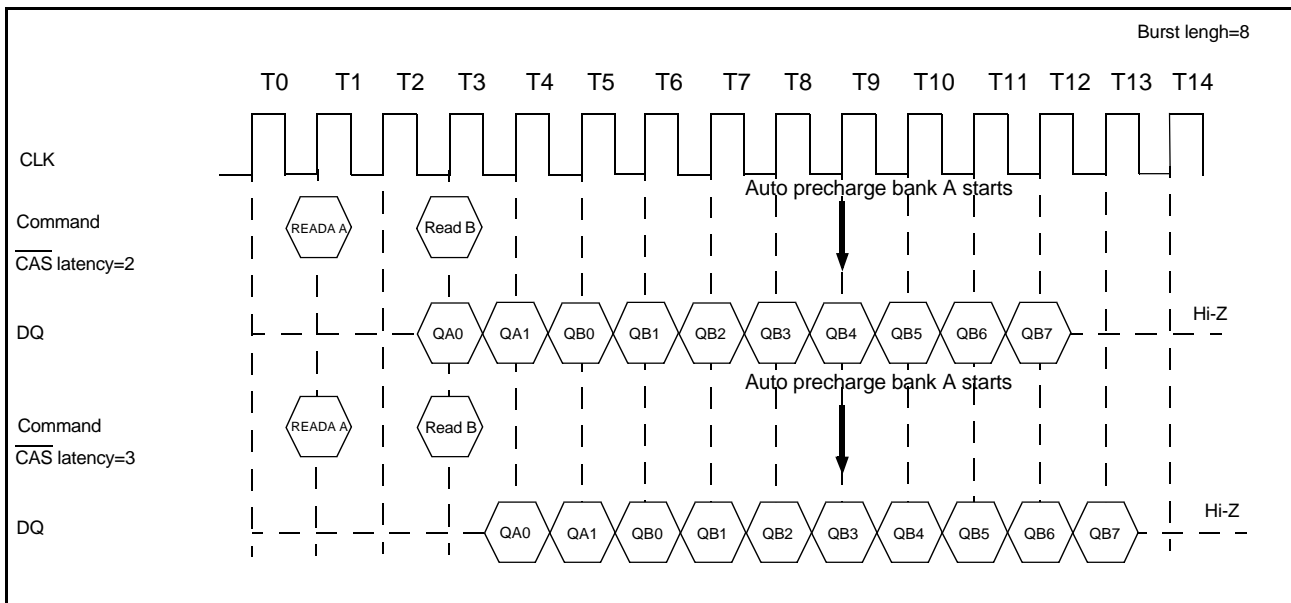

Similar top.21

### 8.4 Multibank Operation- Write with Auto Precharge

During a WRITEA cycle interrupted by a Read, Write command of another banks, the auto-pre-charge scheduled time would not be changed.

#### Multibank Operation

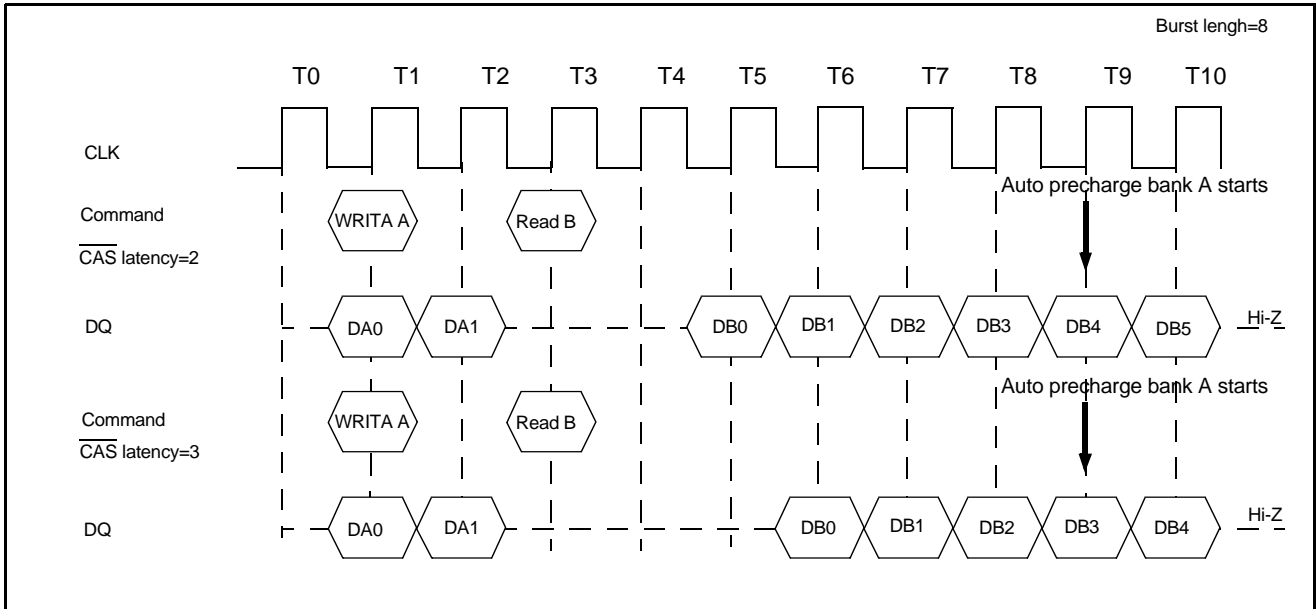

#### Multibank Operation

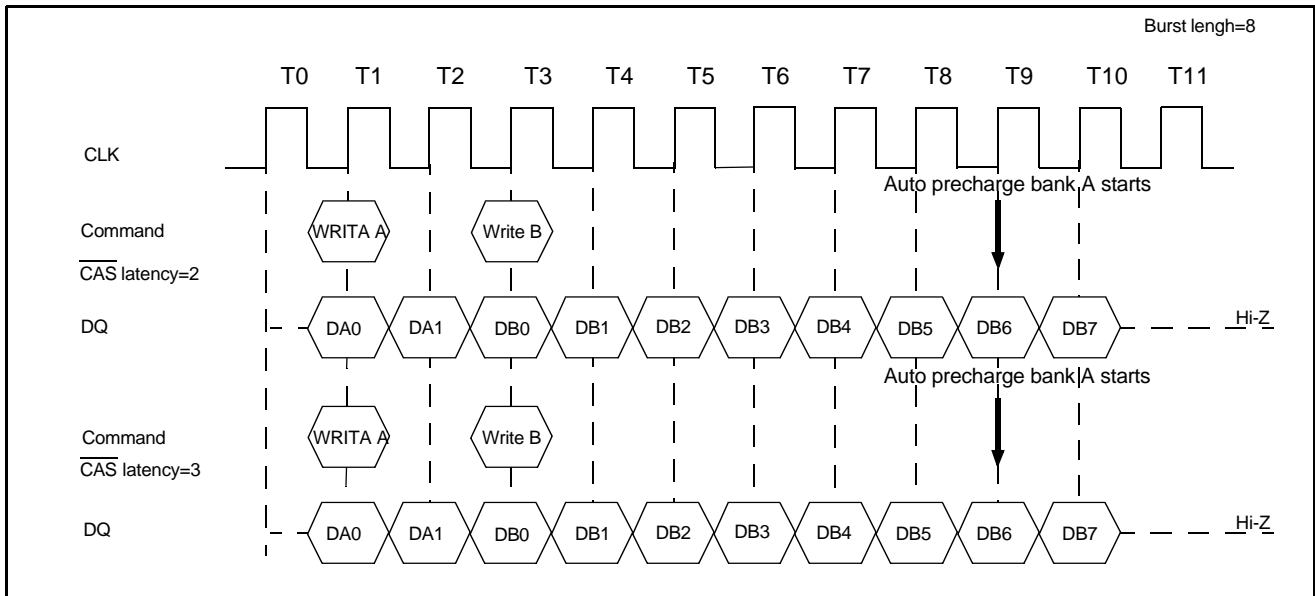

## 9. Read/Write Command Interval

### 9.1 Read to Read command interval

During a read cycle when a new read command is asserted, it will be effective after the  $\overline{\text{CAS}}$  latency, even if the previous read operation has not completed. READ will be interrupted by another READ.

Each read command can be asserted in every clock without any restriction.

#### READ to READ Command Interval

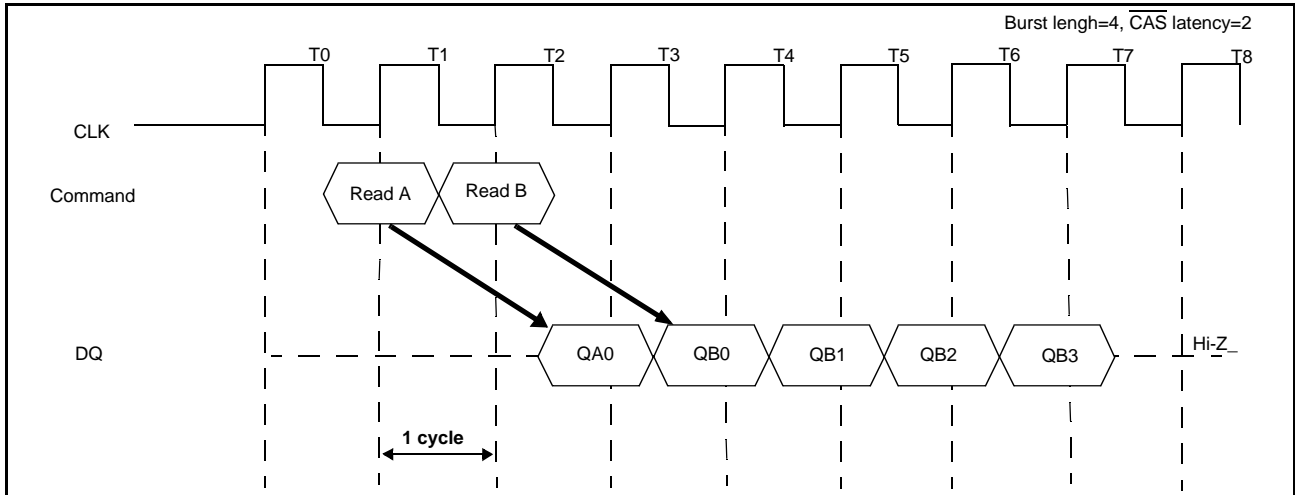

### 9.2 Write to Write Command Interval

During a write cycle, when a new Write command is asserted, the previous burst will be terminated and the new burst will begin with a new write command. WRITE will be interrupted by another WRITE.

Each write command can be asserted in every clock without any restriction.

#### WRITE to WRITE Command Interval

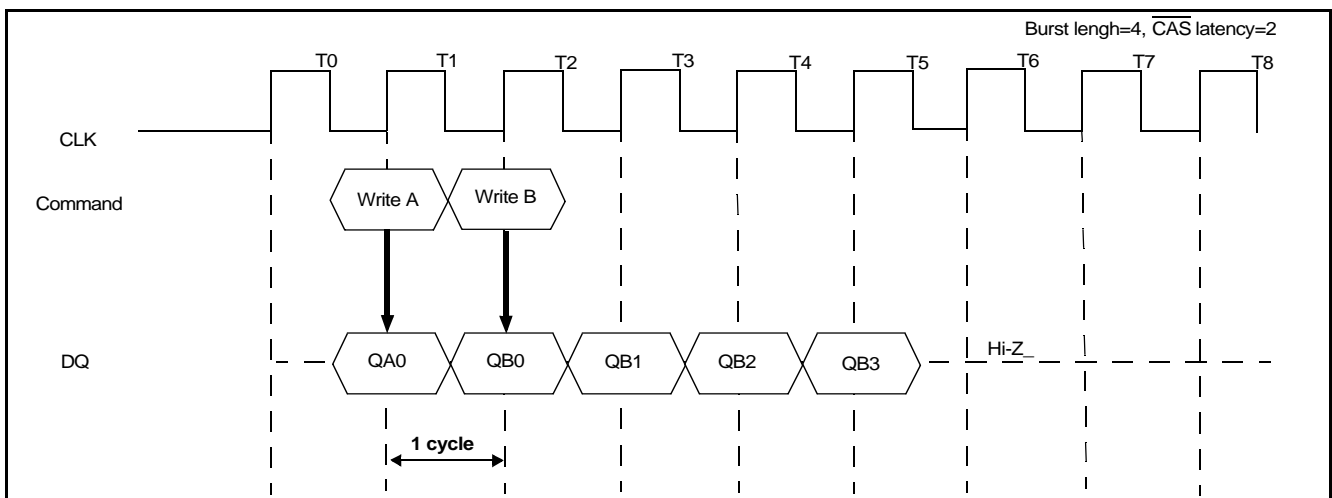

### 9.3 Write to Read Command Interval

The write command to read command interval is also a minimum of 1 cycle. Only the write data before the read command will be written. The data bus must be Hi-Z at least one cycle prior to the first D<sub>OUT</sub>.

#### WRITE to READ Command Interval

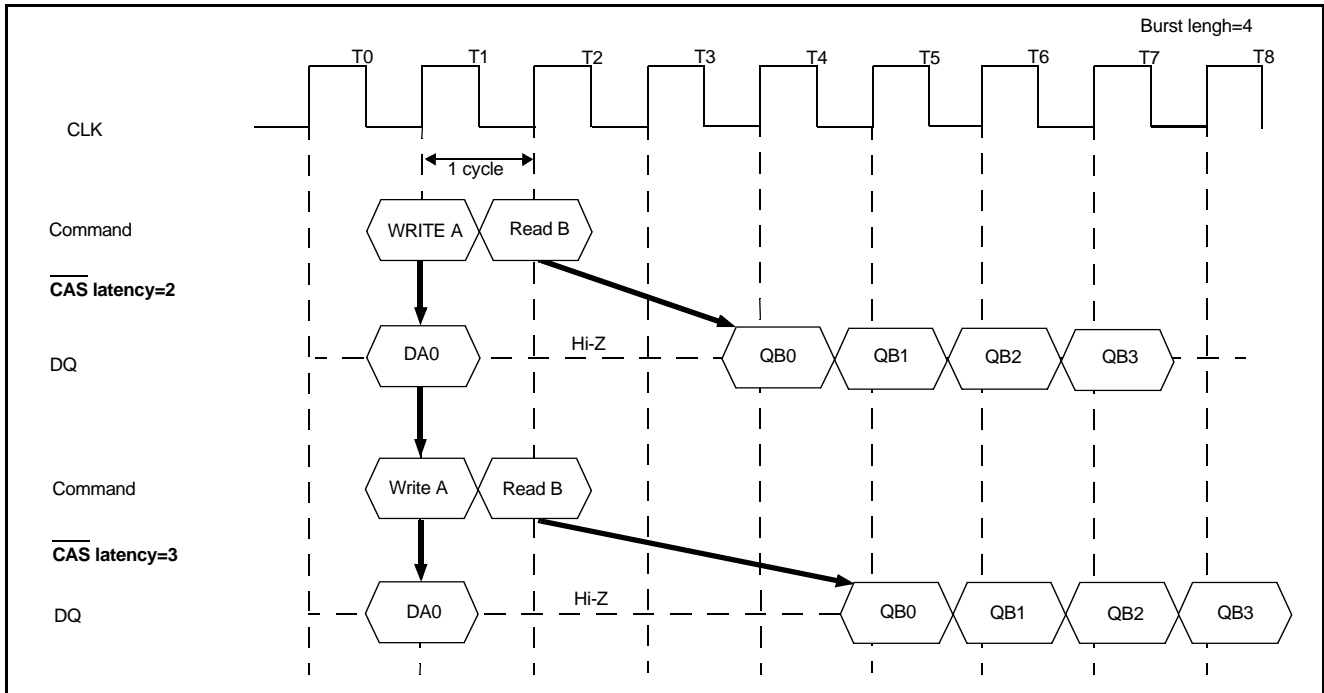

### 9.4 Read to Write Command Interval

During a read cycle, READ can be interrupted by WRITE.

DQM must be in High at least 3 clocks prior to the write command. There is a restriction to avoid a data conflict. The data bus must be Hi-Z using DQM before Write.

READ to WRITE Command Interval

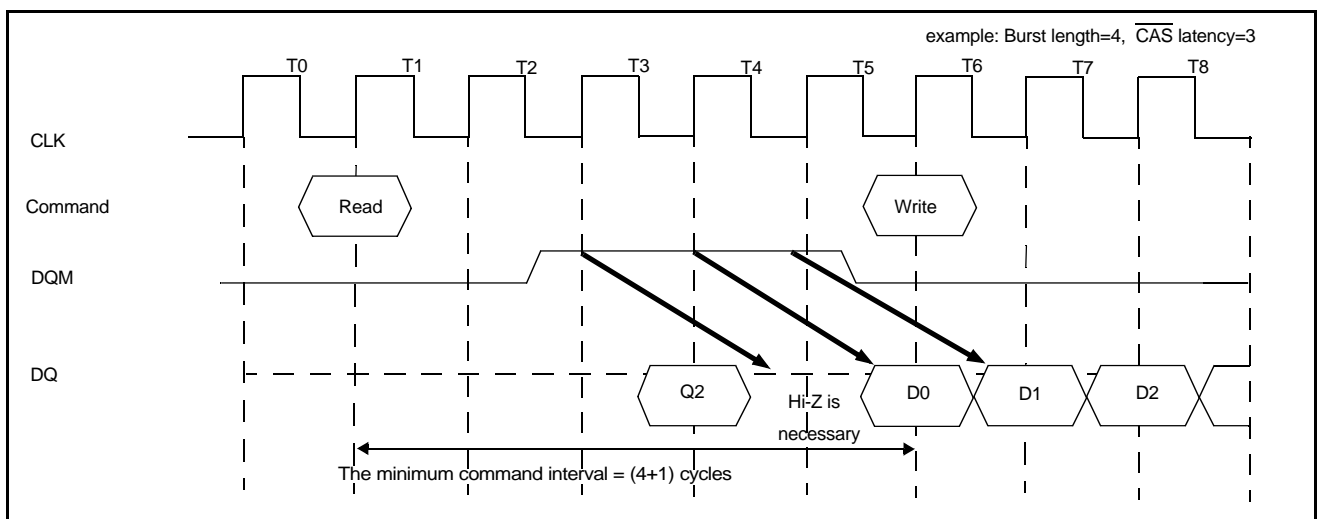
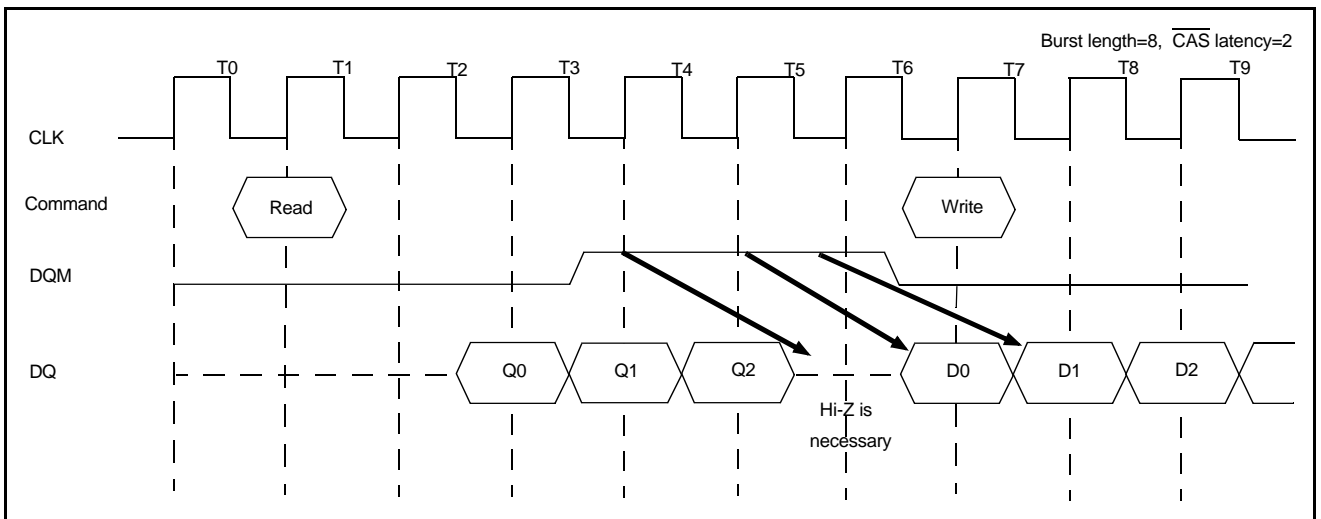
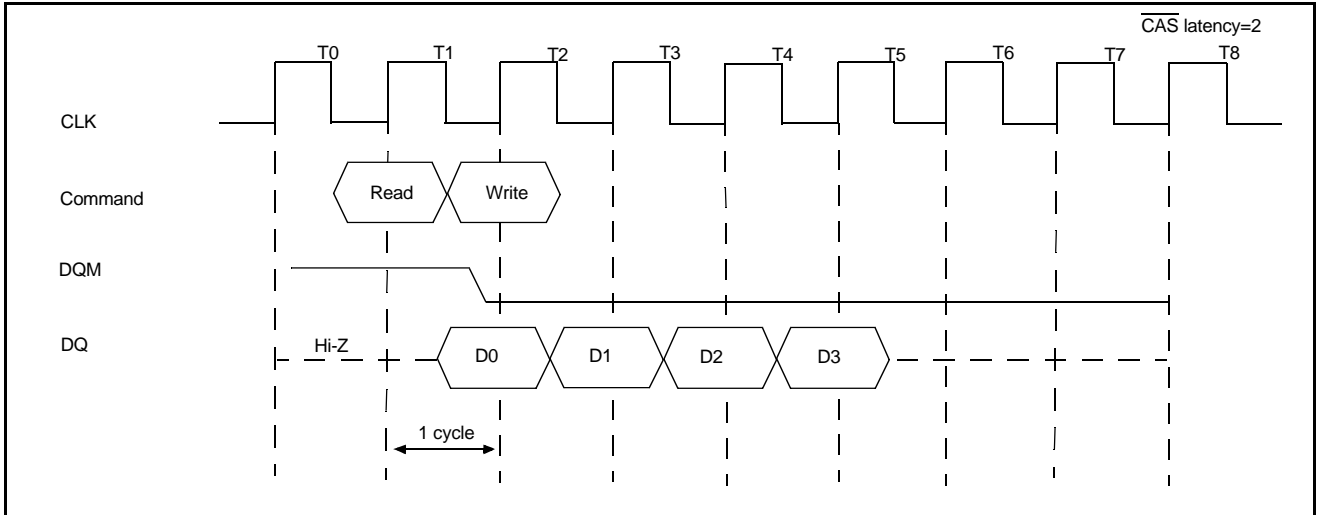



### 10.BURST Termination

There are two methods to terminate a burst operation other than using a read or a write command. One is the burst stop command and the other is the precharge command.

#### 10.1 BURST Stop Command

During a read burst, when the burst stop command is asserted, the burst read data are terminated and the data bus goes to high-impedance after the  $\overline{\text{CAS}}$  latency from the burst stop command.

During a write burst, when the burst stop command is asserted, any data provided at that cycle will not be written. The burst write is effectively terminated and no further data can be written until a new write command is asserted.

#### Burst Termination

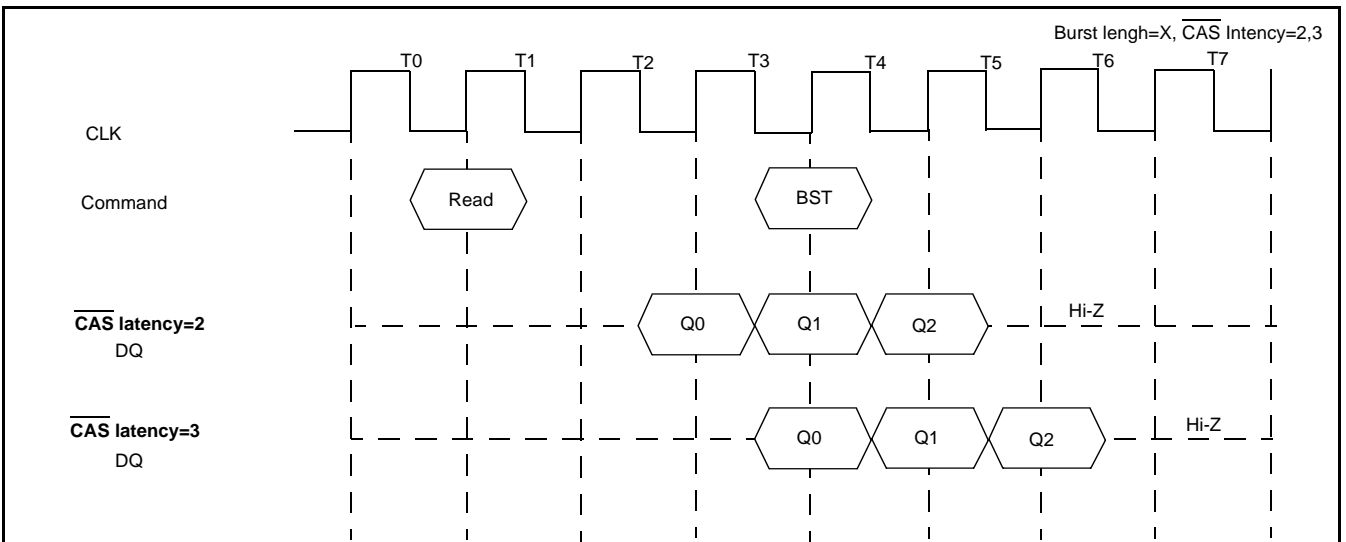

Remark BST: Burst stop command

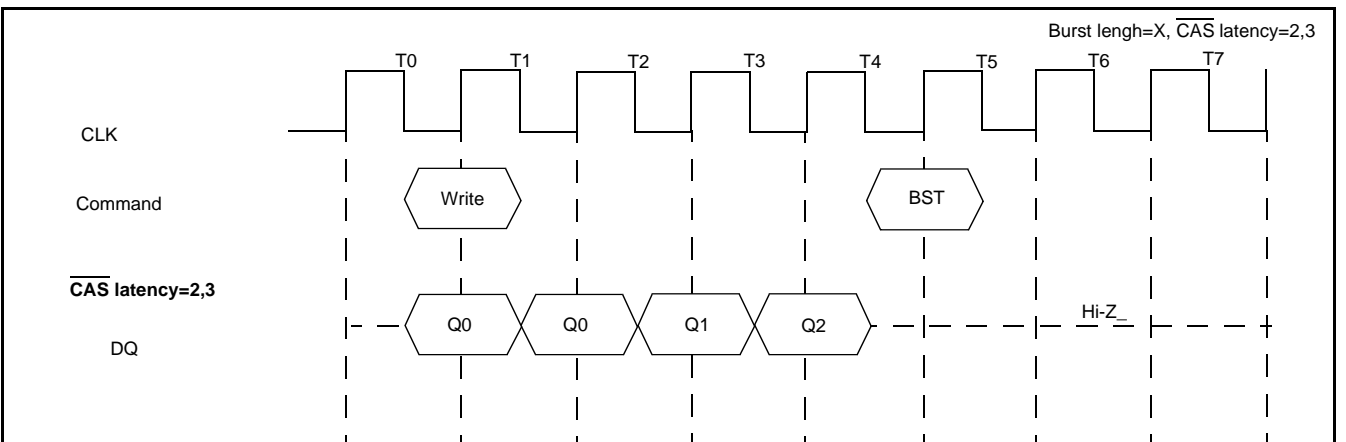

Remark BST: Burst command

## 10.2 PRECHARGE TERMINATION

### 10.2.1 PRECHARGE TERMINATION in READ Cycle

During READ cycle, the burst read operation is terminated by a precharge command. When the precharge command is asserted, the burst read operation is terminated and precharge starts.

The same bank can be activated again after  $t_{RP}$  from the precharge command.

When CAS latency is 2, the read data will remain valid until one clock after the precharge command.

When CAS latency is 3, the read data will remain valid until two clocks after the precharge command.

#### Precharge Termination in READ Cycle

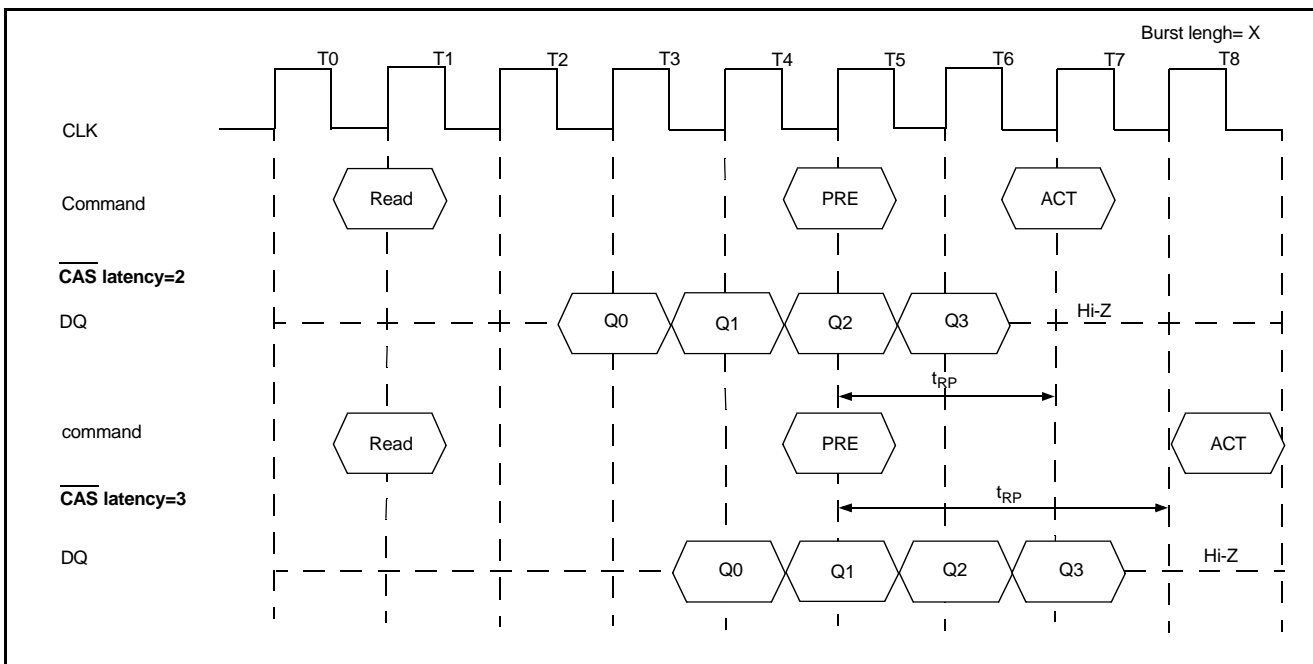

### 10.2.2 Precharge Termination in WRITE Cycle

During WRITE cycle, the burst write operation is terminated by a precharge command. When the precharge command is asserted, the burst write operation is terminated and precharge starts.

The same bank can be activated again after  $t_{RP}$  from the precharge command. The DQM must be high to mask invalid data in.

During WRITE cycle, the write data written prior to the precharge command will be correctly stored. However, invalid data may be written at the same clock as the precharge command. To prevent this from happening, DQM must be high at the same clock as the precharge command. This will mask the invalid data.

#### PRECHARGE TERMINATION in WRITE Cycle

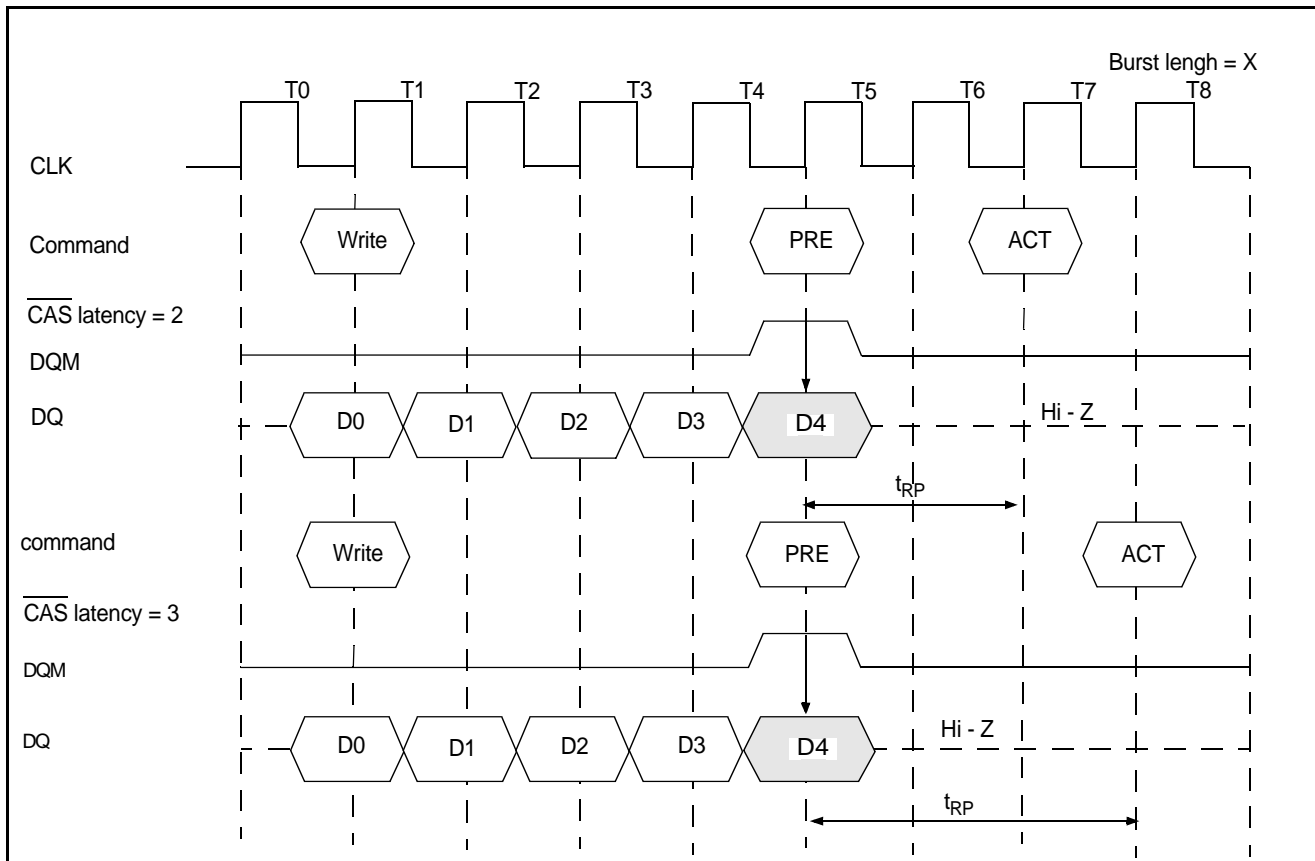

# Timing Diagram

Mode Register Set

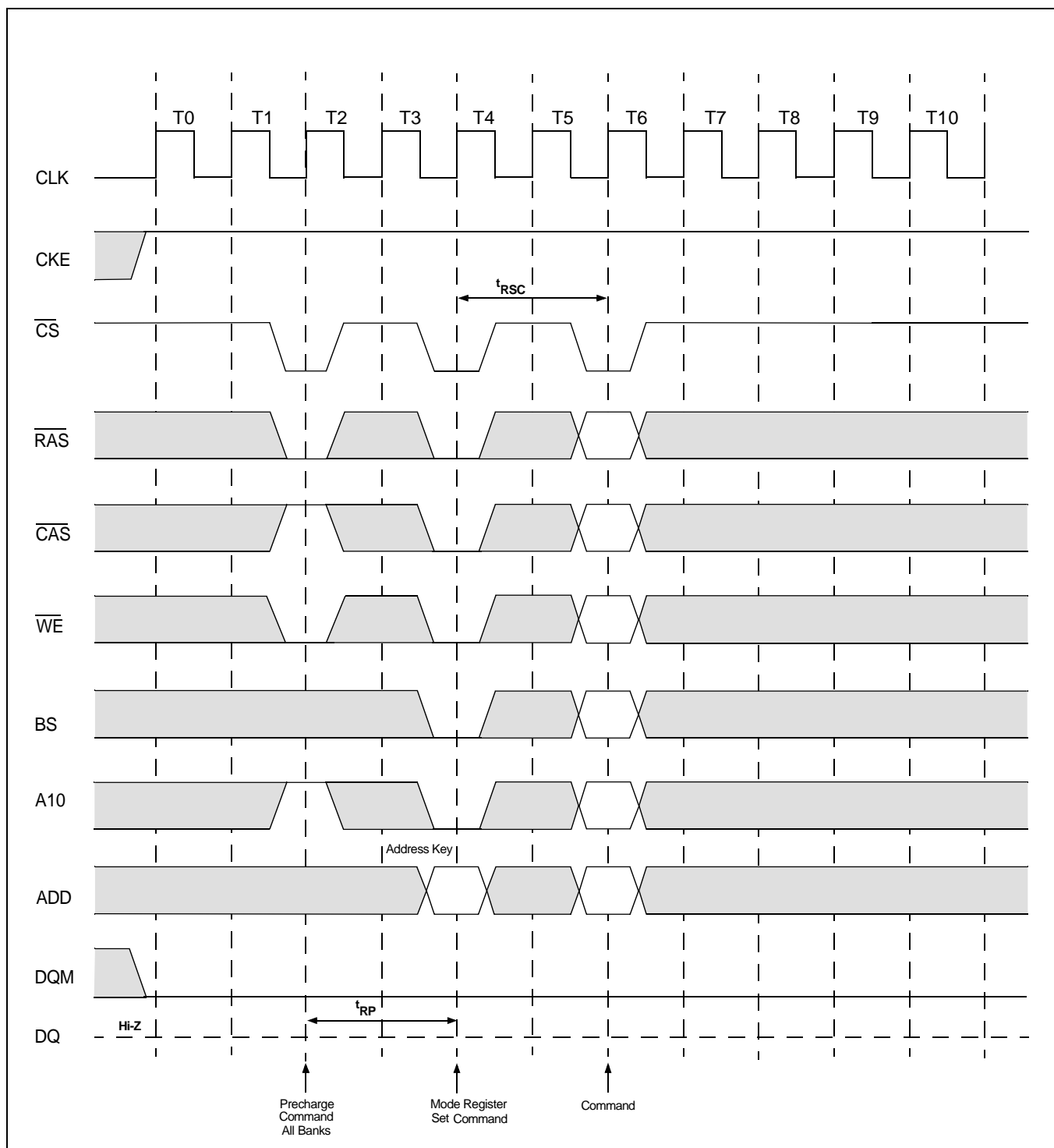

AC Parameters for Write Timing (1 of 2)

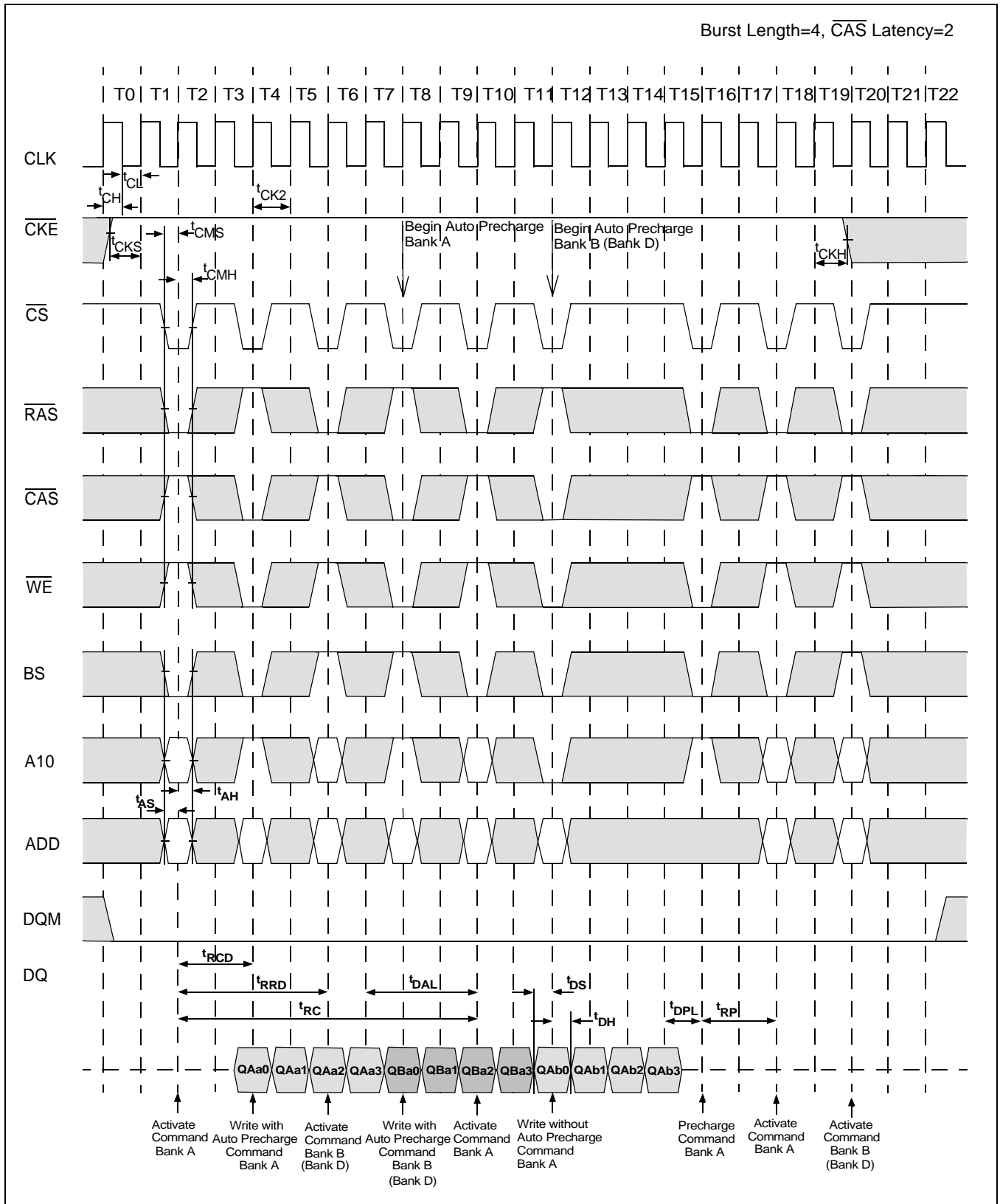

AC Parameters for Write Timing (2 of 2)

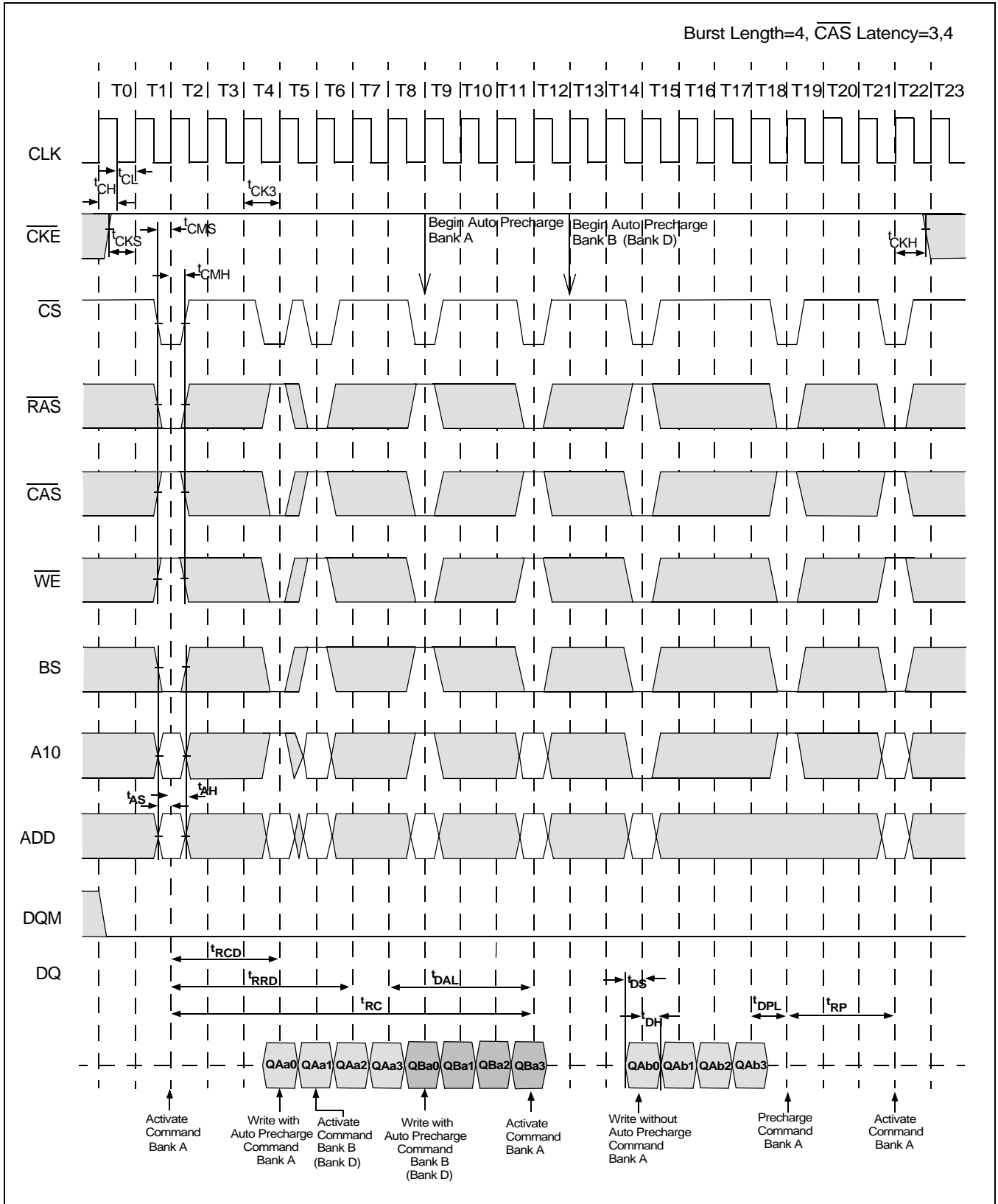

AC Parameters for Read Timing (1 of 2)

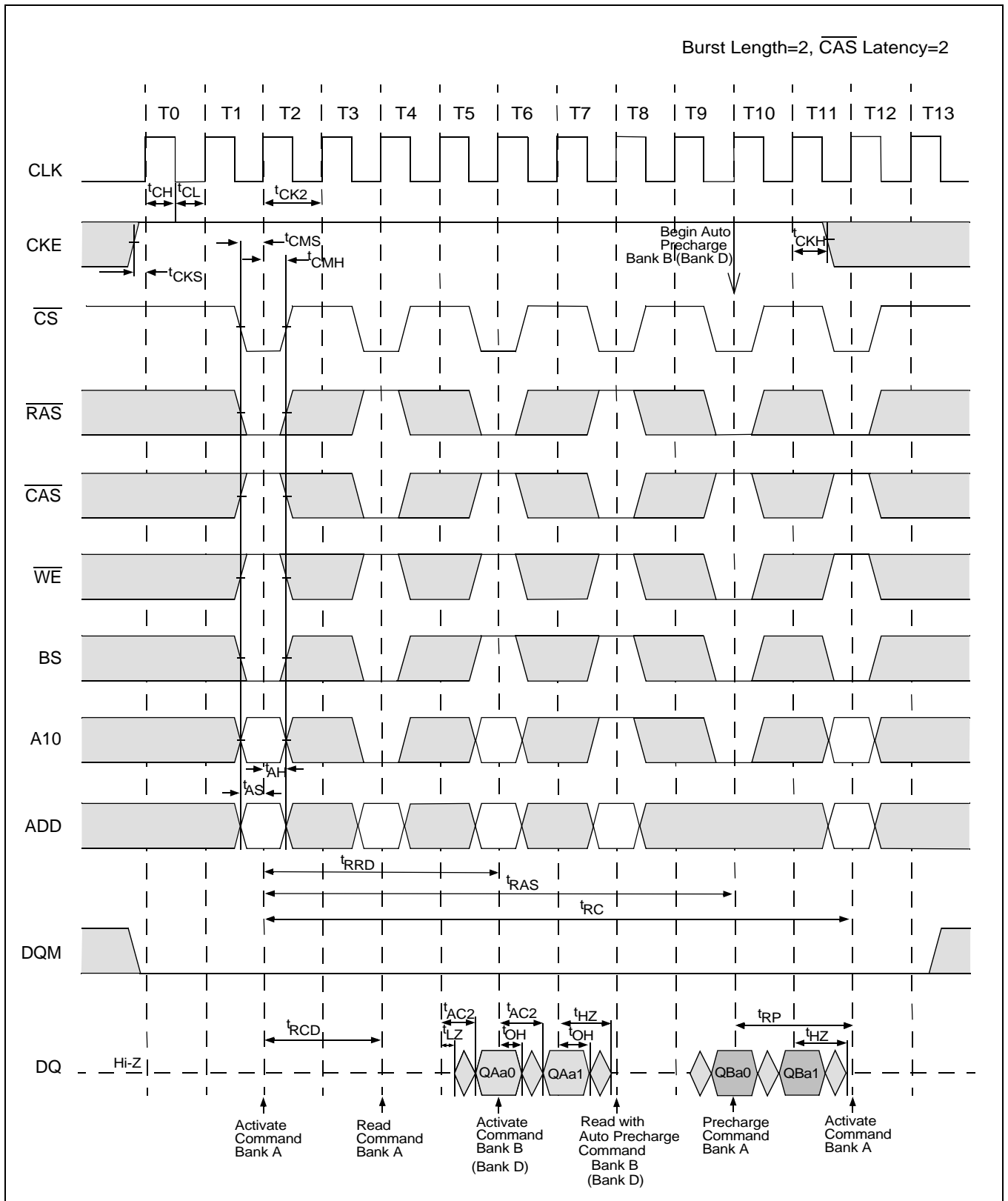



AC Parameters for Read Timing (2 of 2)

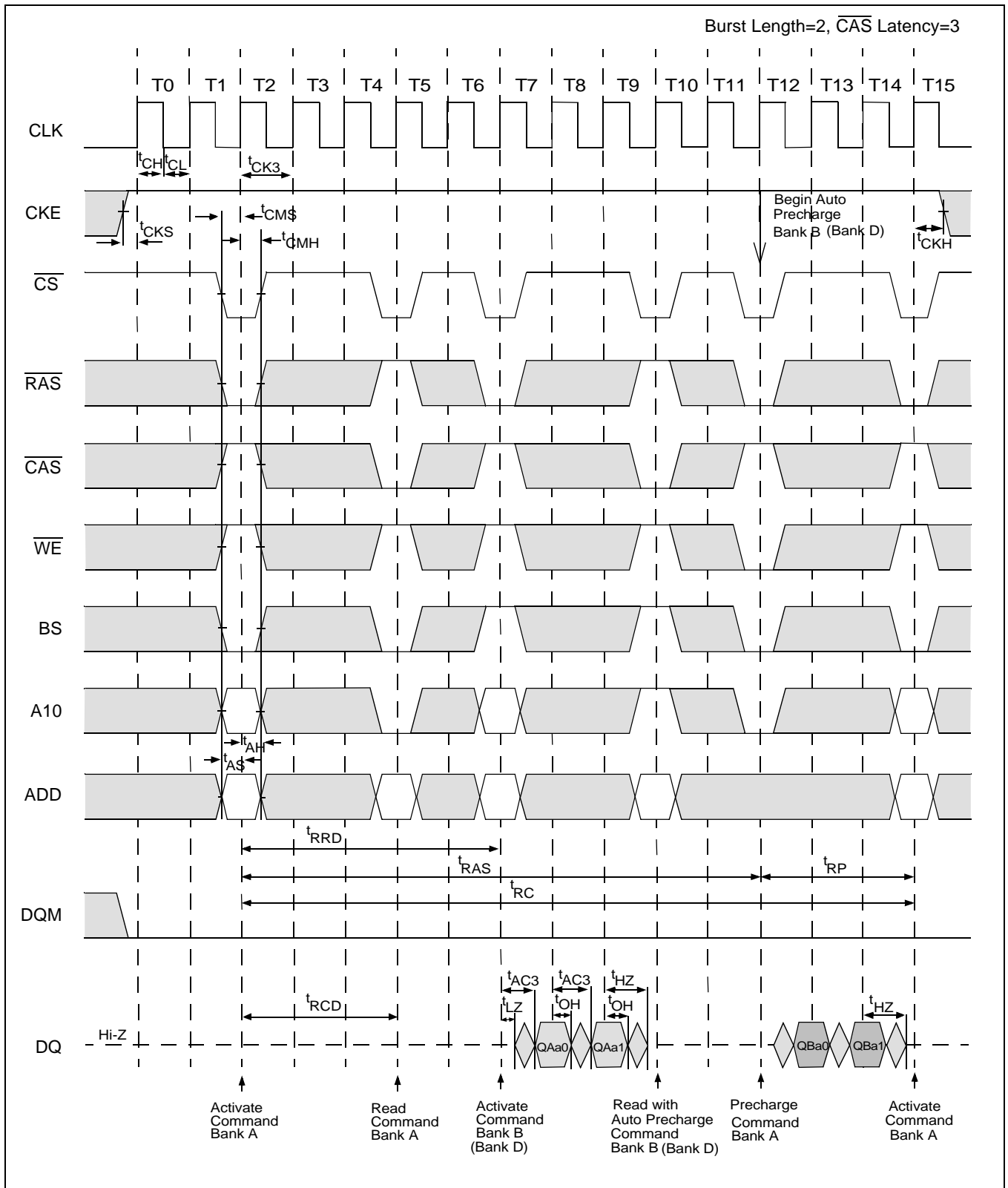

Power on Sequence and Auto Refresh (CBR)

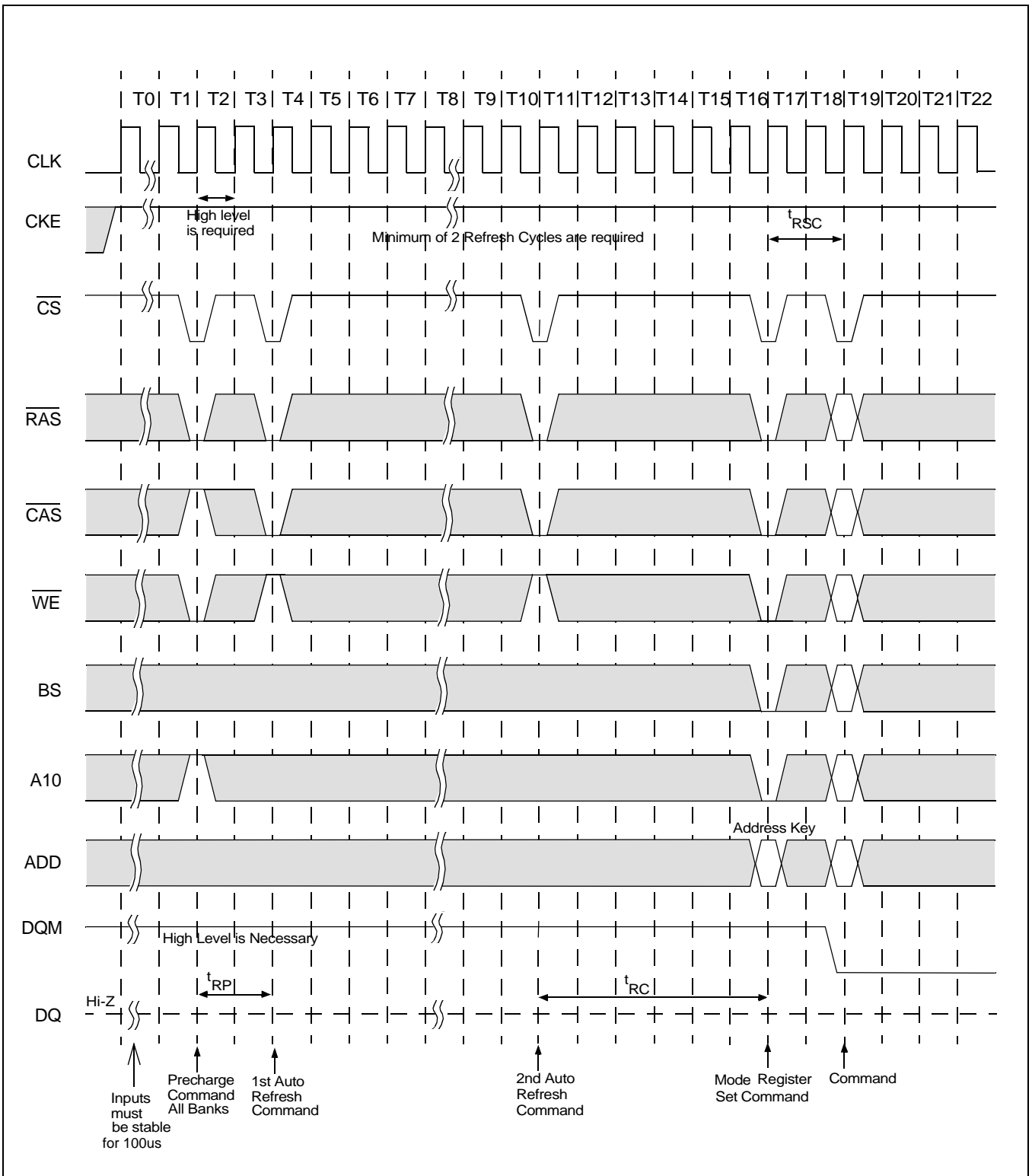

**Clock Suspension During Burst Read (Using CKE) (1 of 2)**

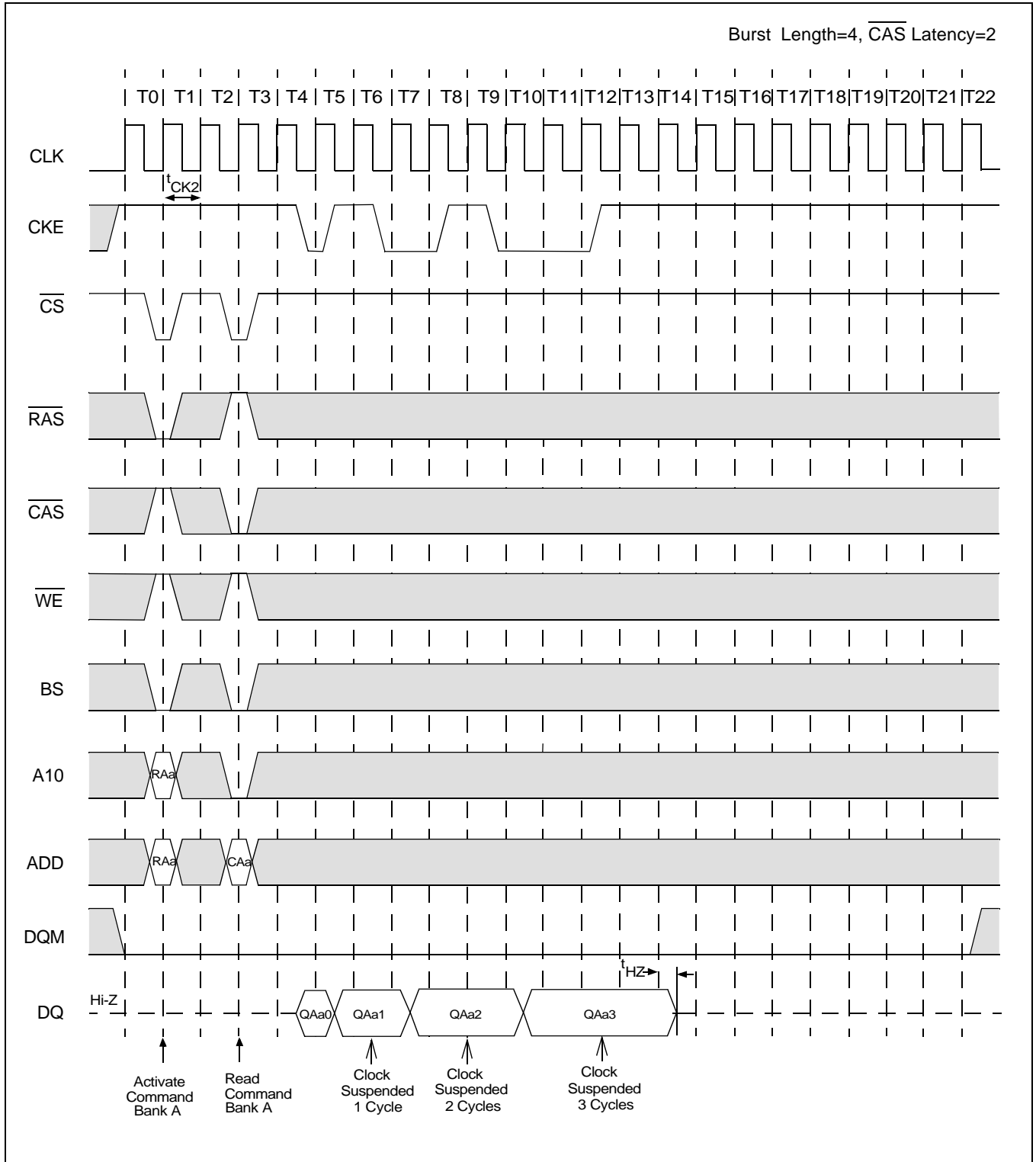

**Clock Suspension During Burst Read (Using CKE) (2 of 2)**

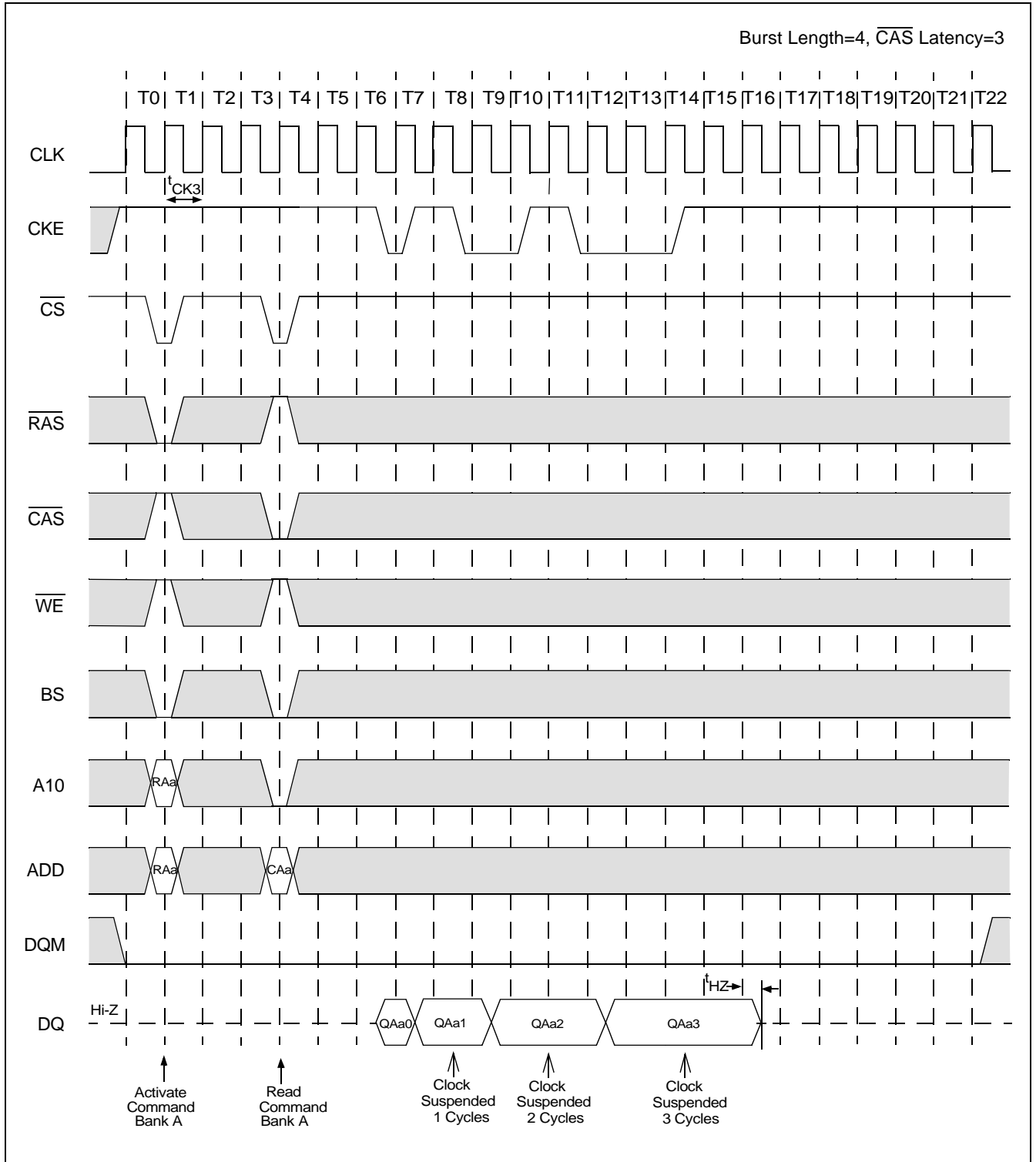

**Clock Suspension During Burst Write (Using CKE) (1 of 2)**

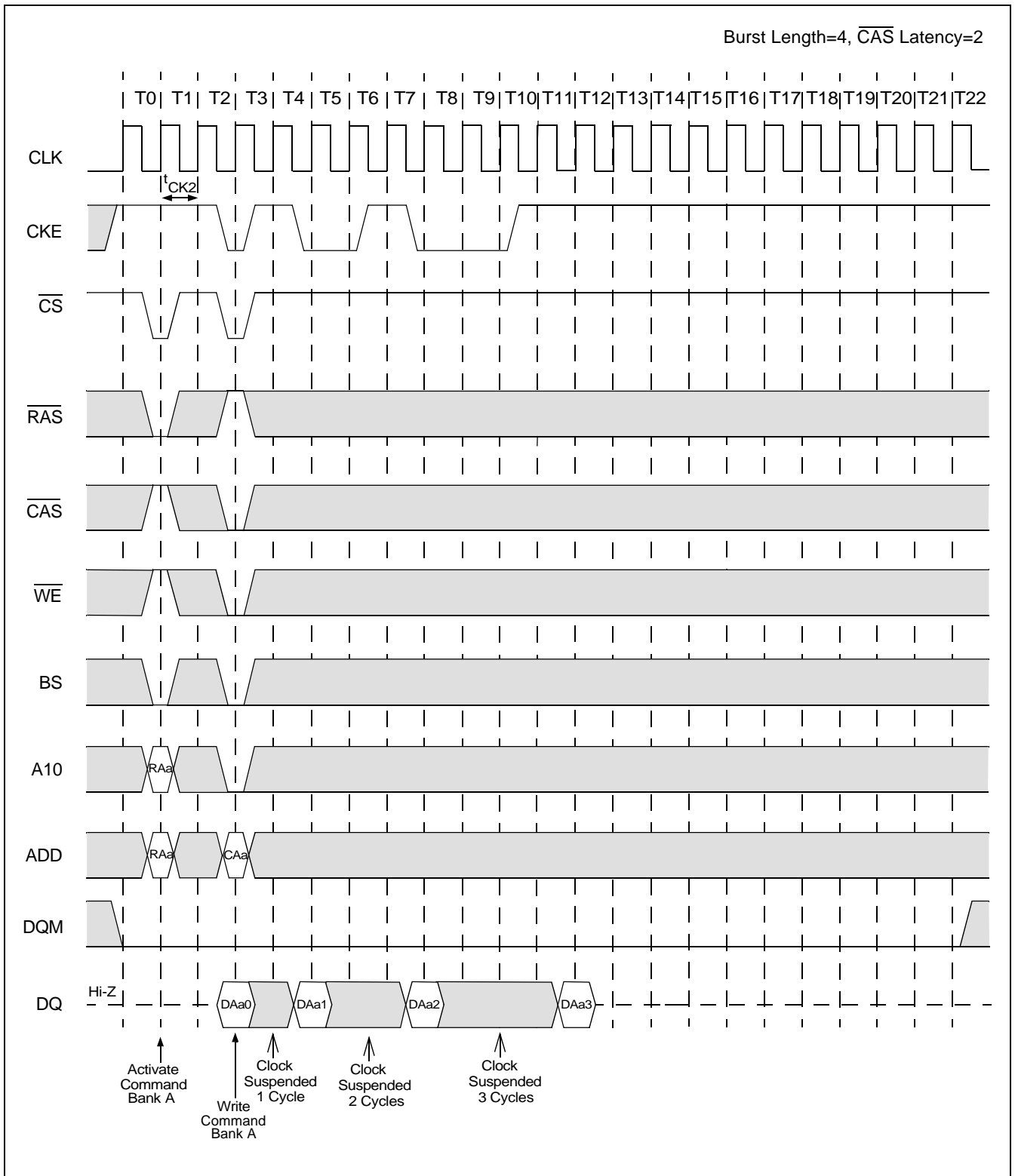

**Clock Suspension During Burst Write (Using CKE) (2 of 2)**

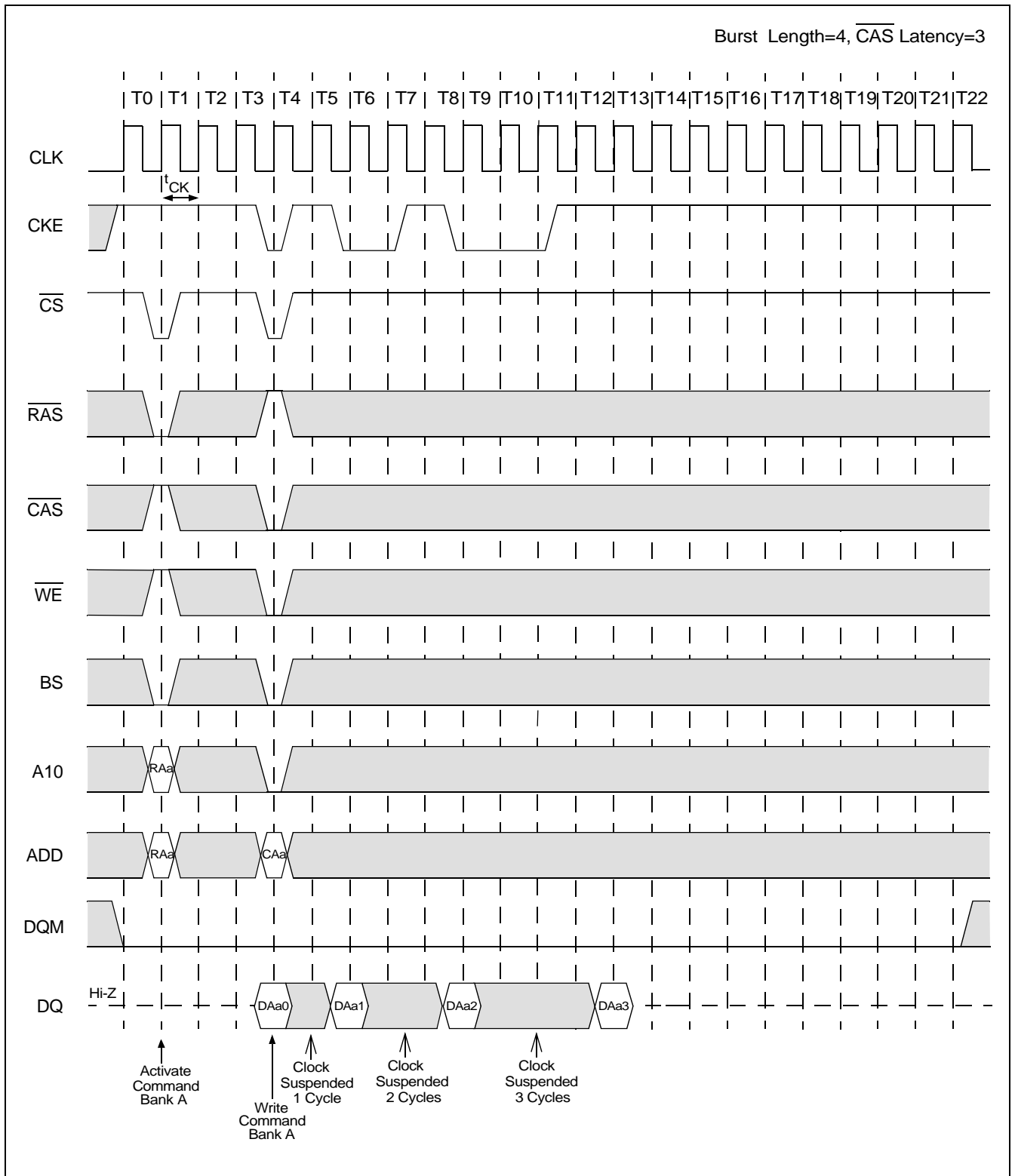

Power Down Mode and Clock Mask

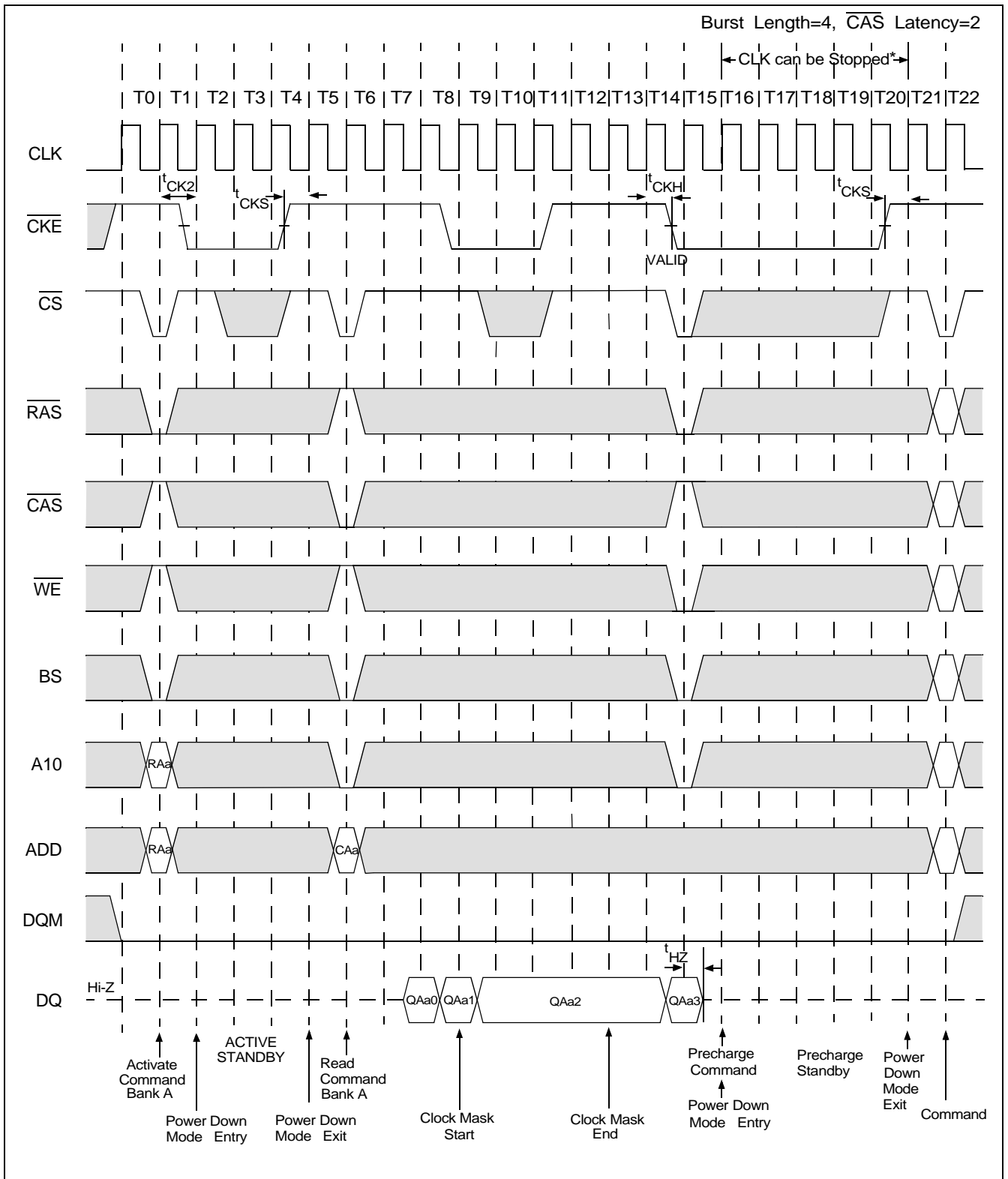

Auto Refresh (CBR)

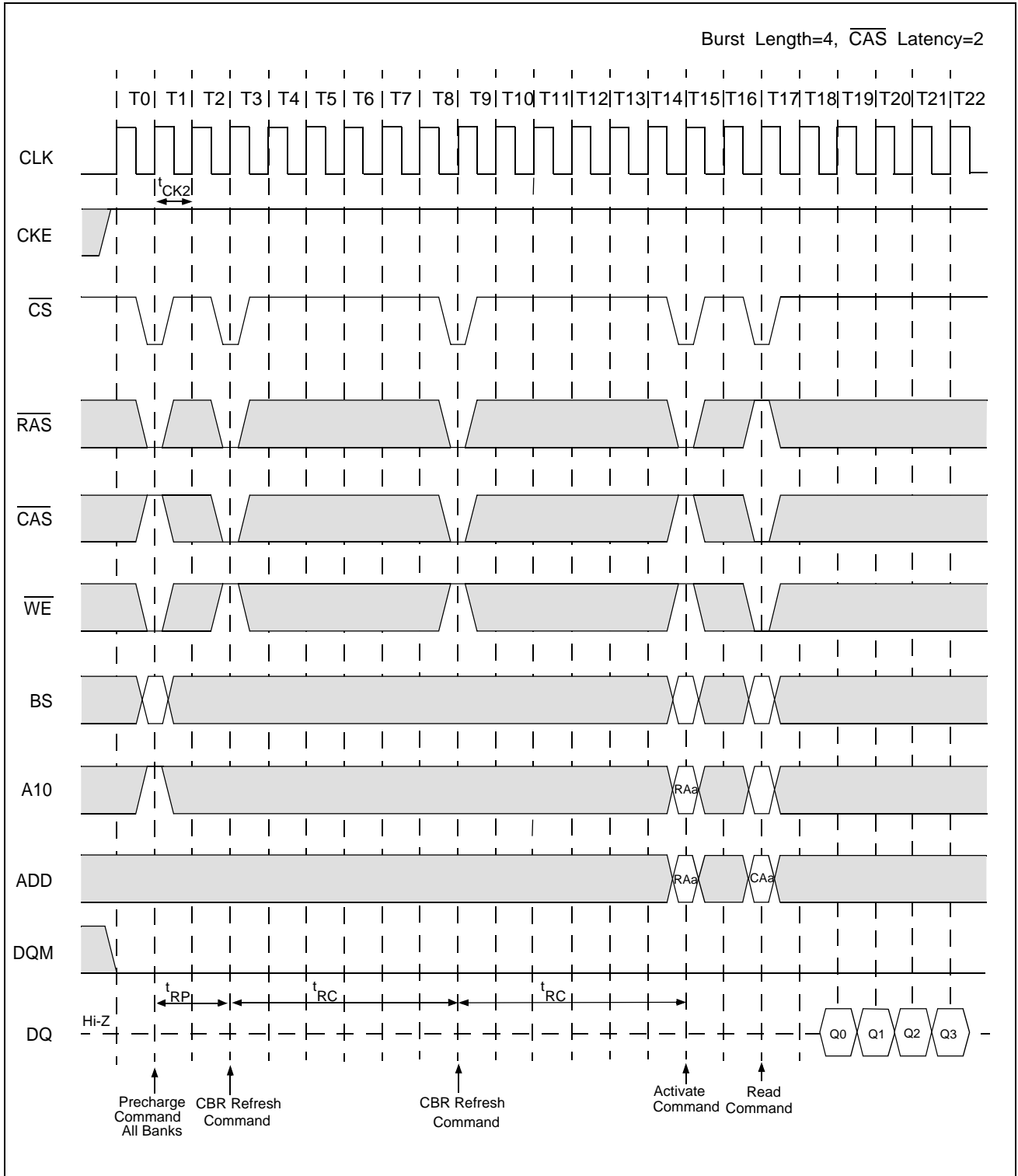



Self Refresh (Entry and Exit)

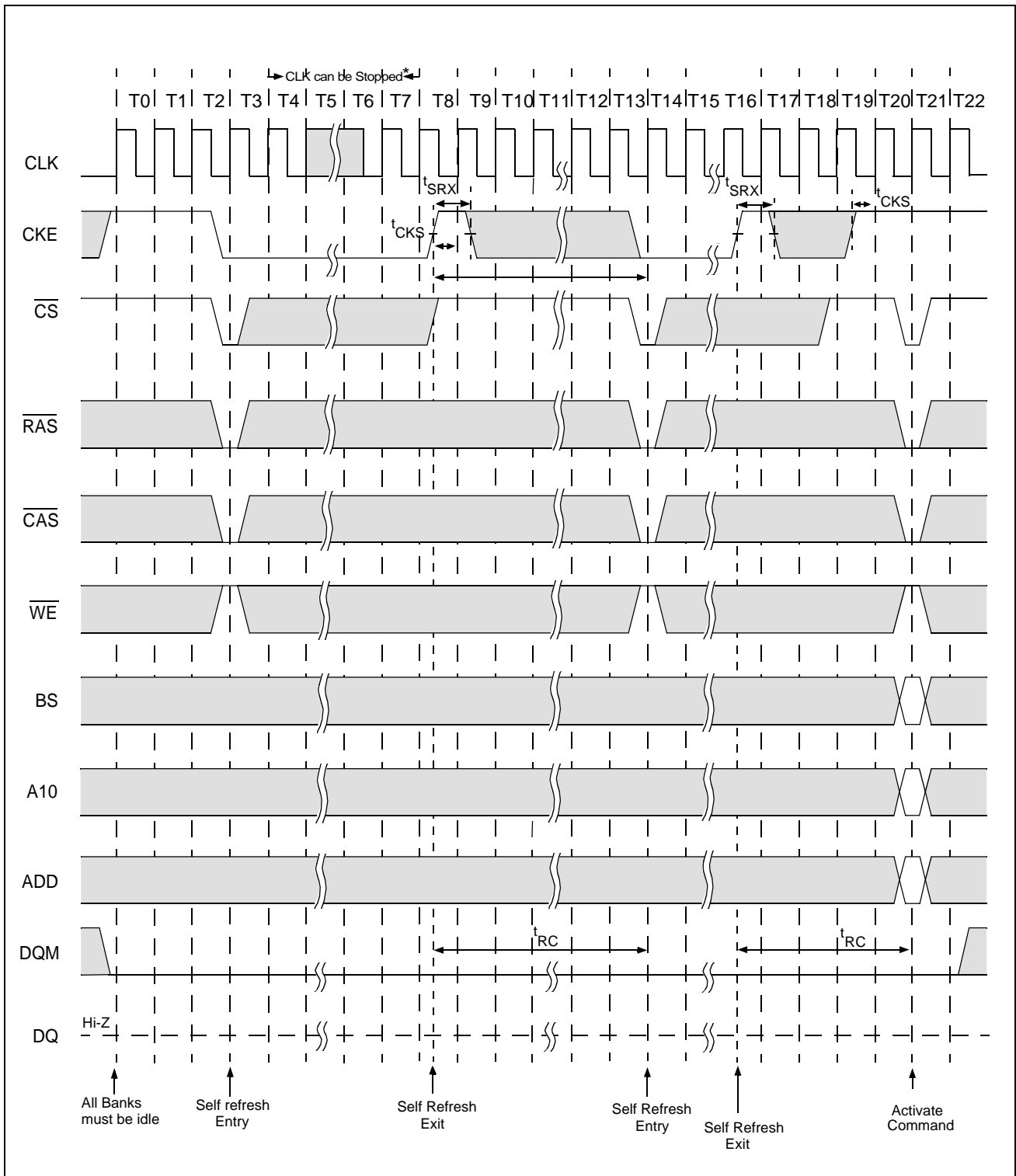

\* Clock can be stopped at CKE=Low. If clock is stopped, it must be restarted/stable for 4 clock cycles before CKE=High

Random Column Read (Page Within same Bank)(1 of 2)

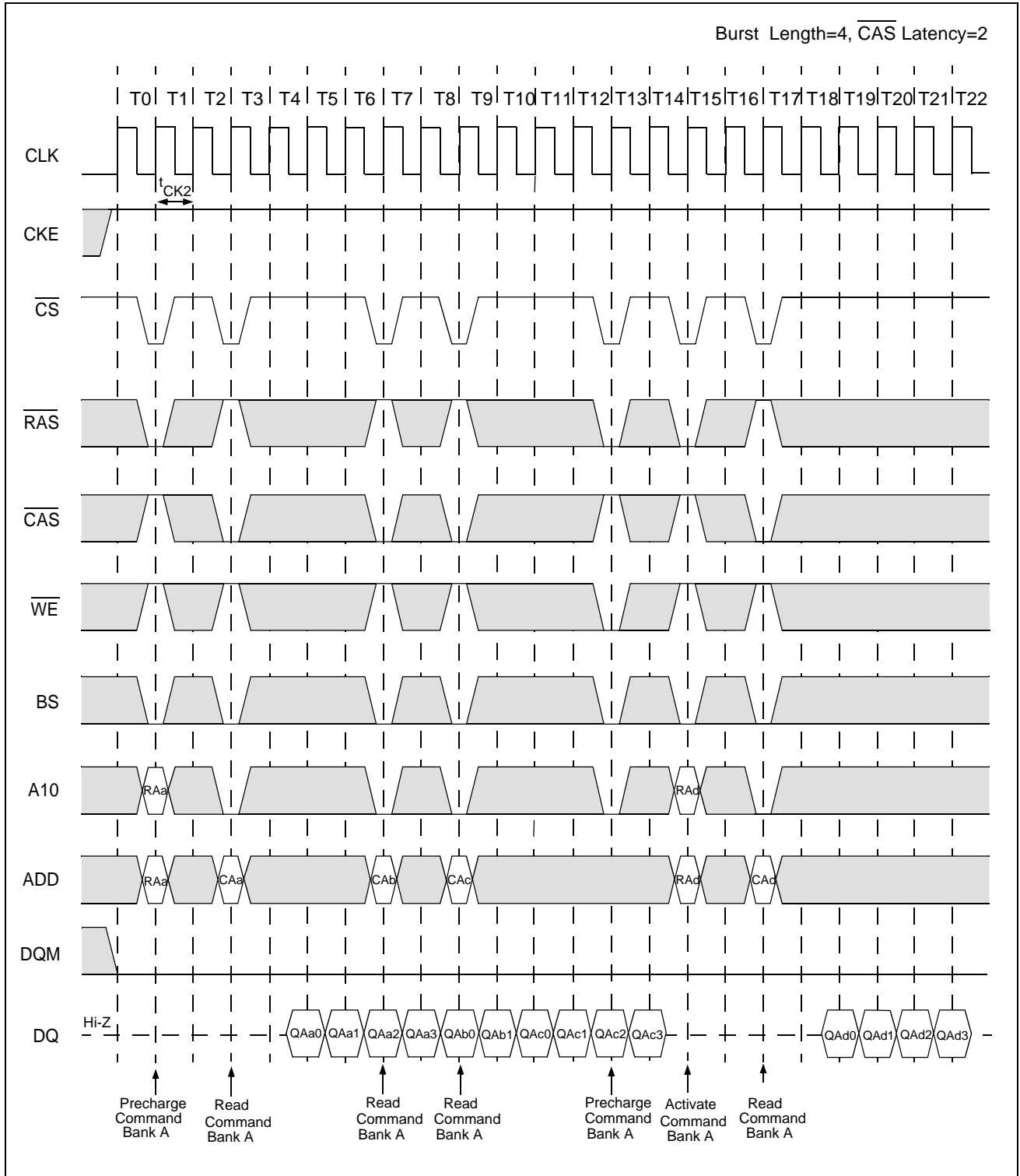

Random Column Read (Page Within same Bank)(2 of 2)

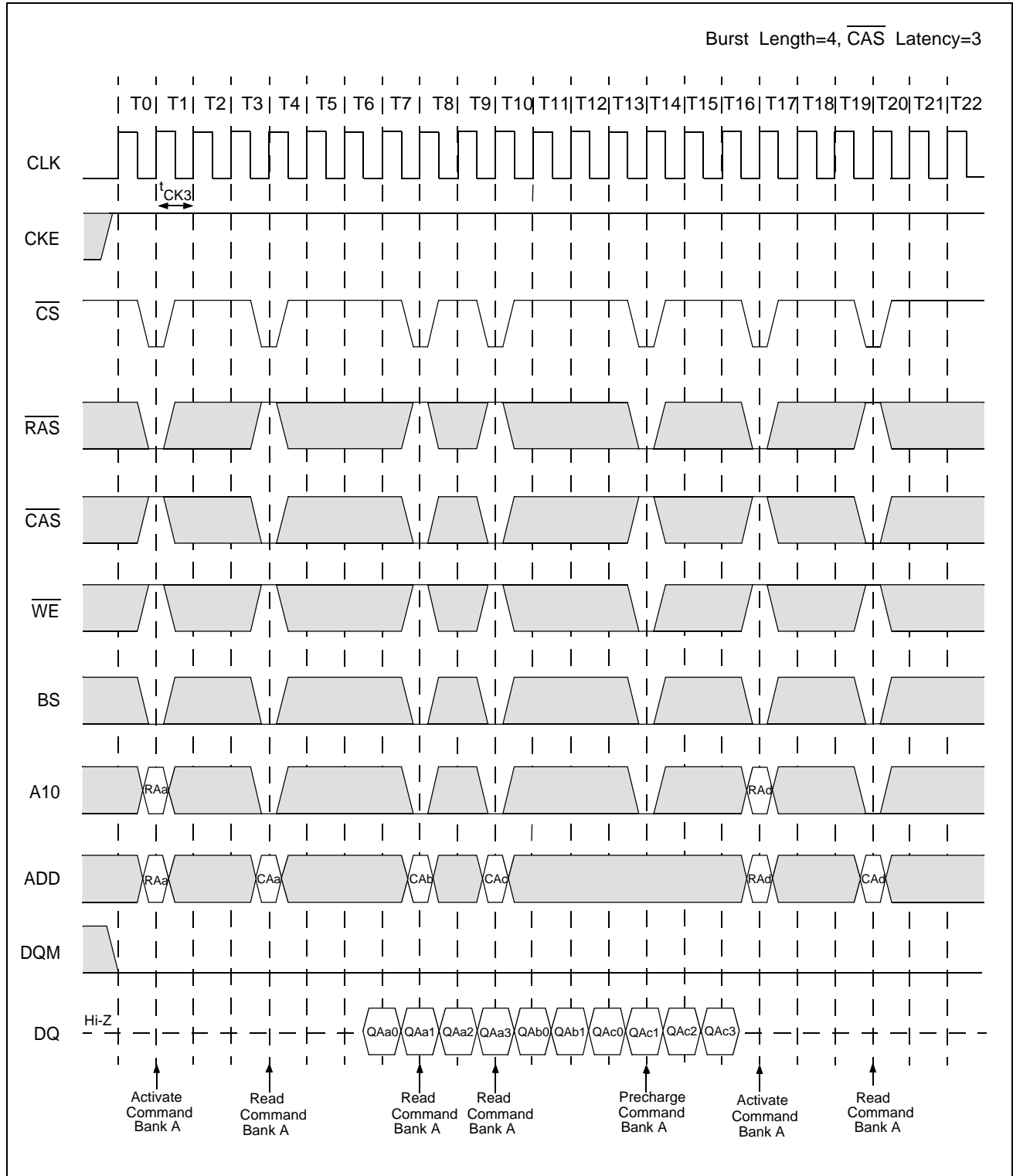

Random Column Write (Page Within same Bank) (1 of 2)

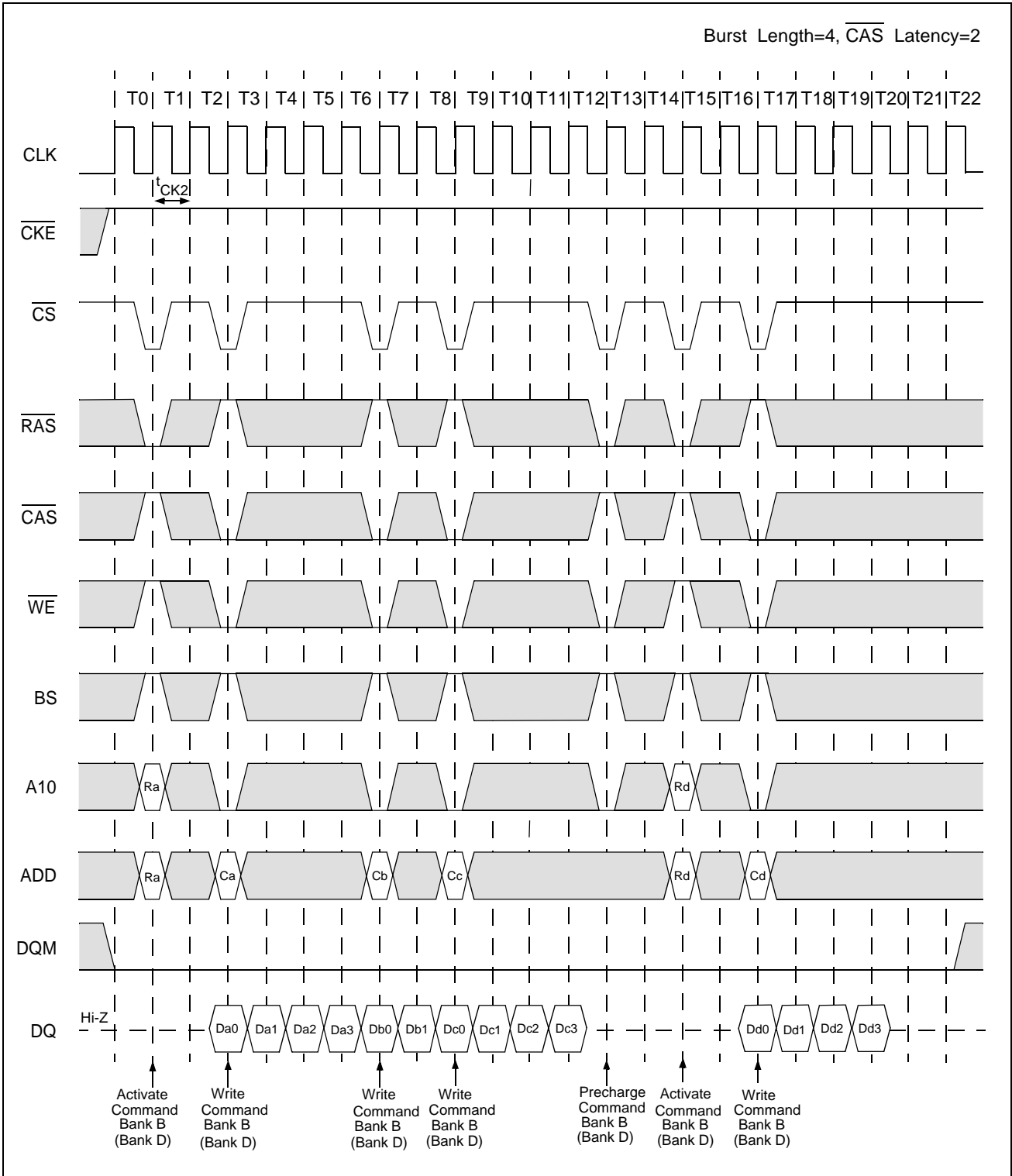

Random Column Write (Page Within same Bank) (1 of 2)

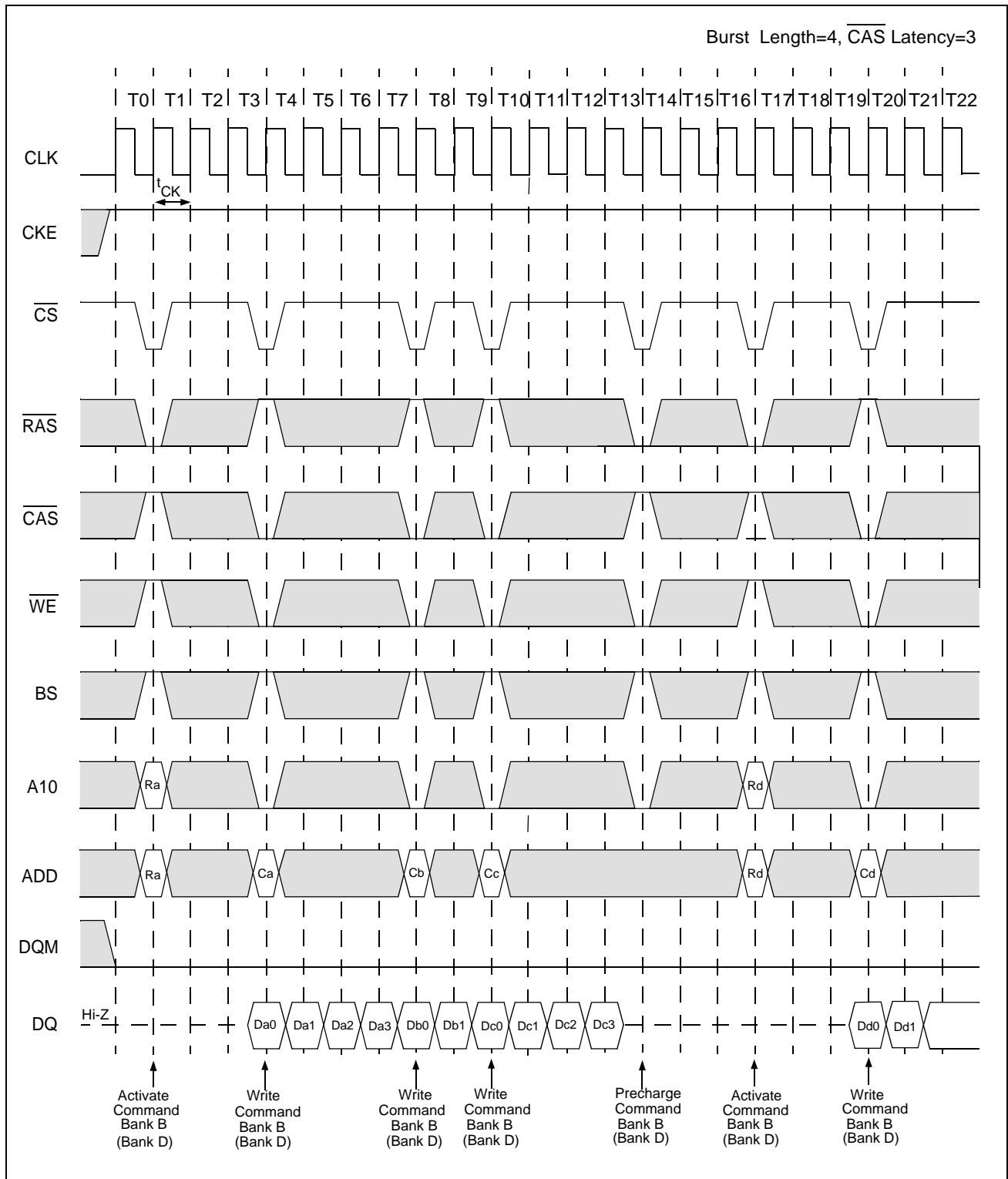

Random Row Read (Interleaving Banks)(1 of 2)

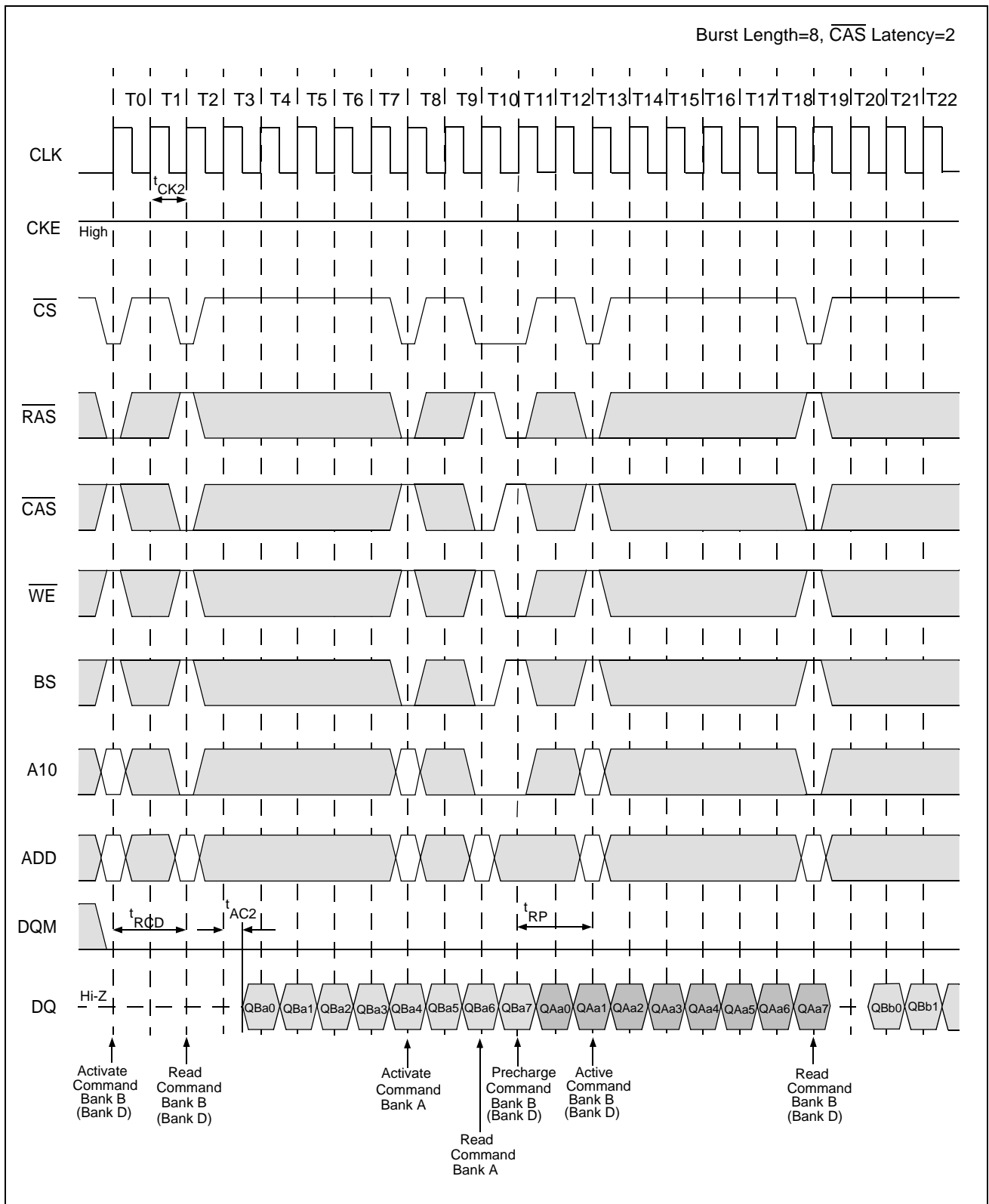

Random Row Read (Interleaving Banks) (2 of 3)

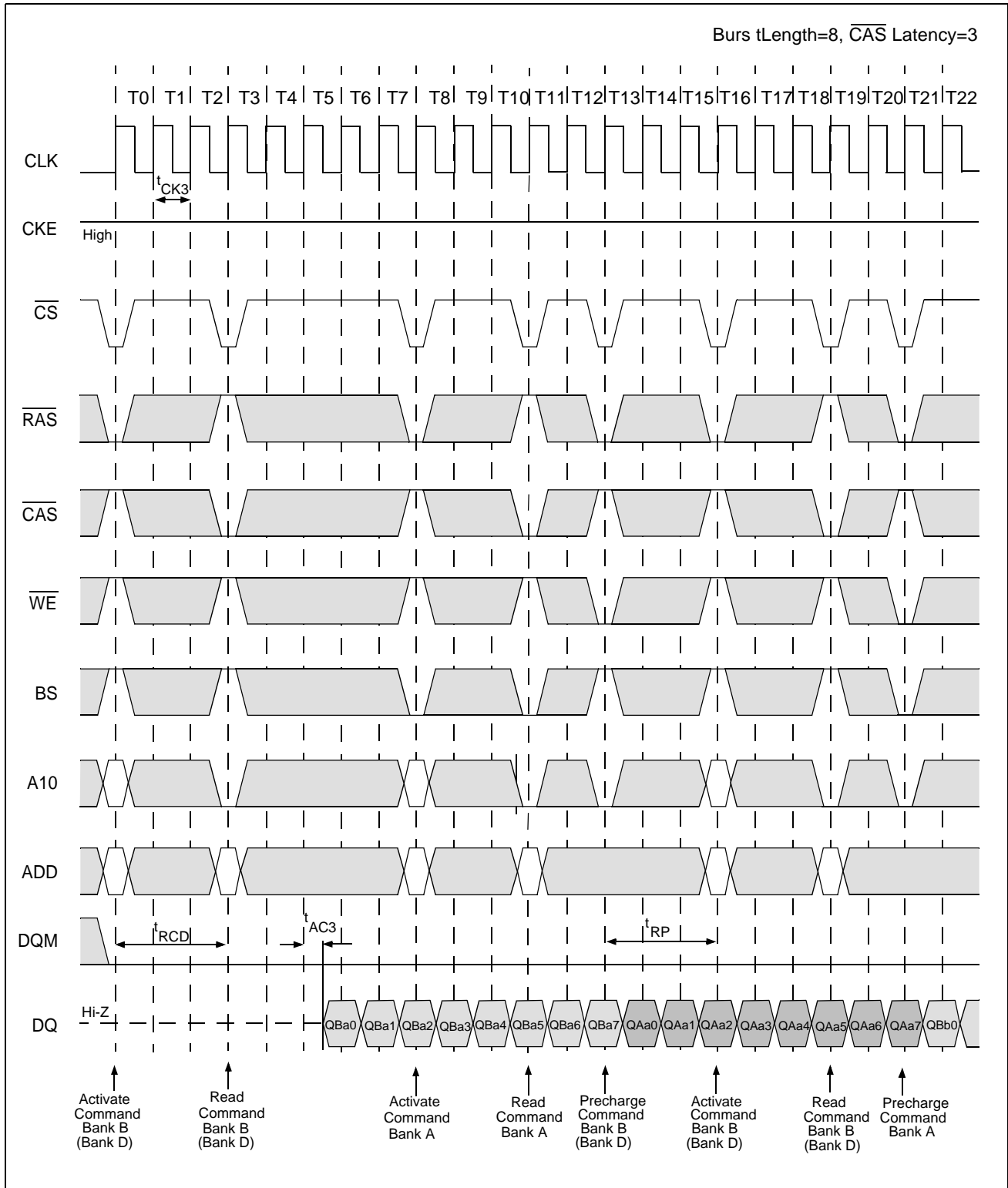

Random Row Write (Interleaving Banks) (1 of 2)

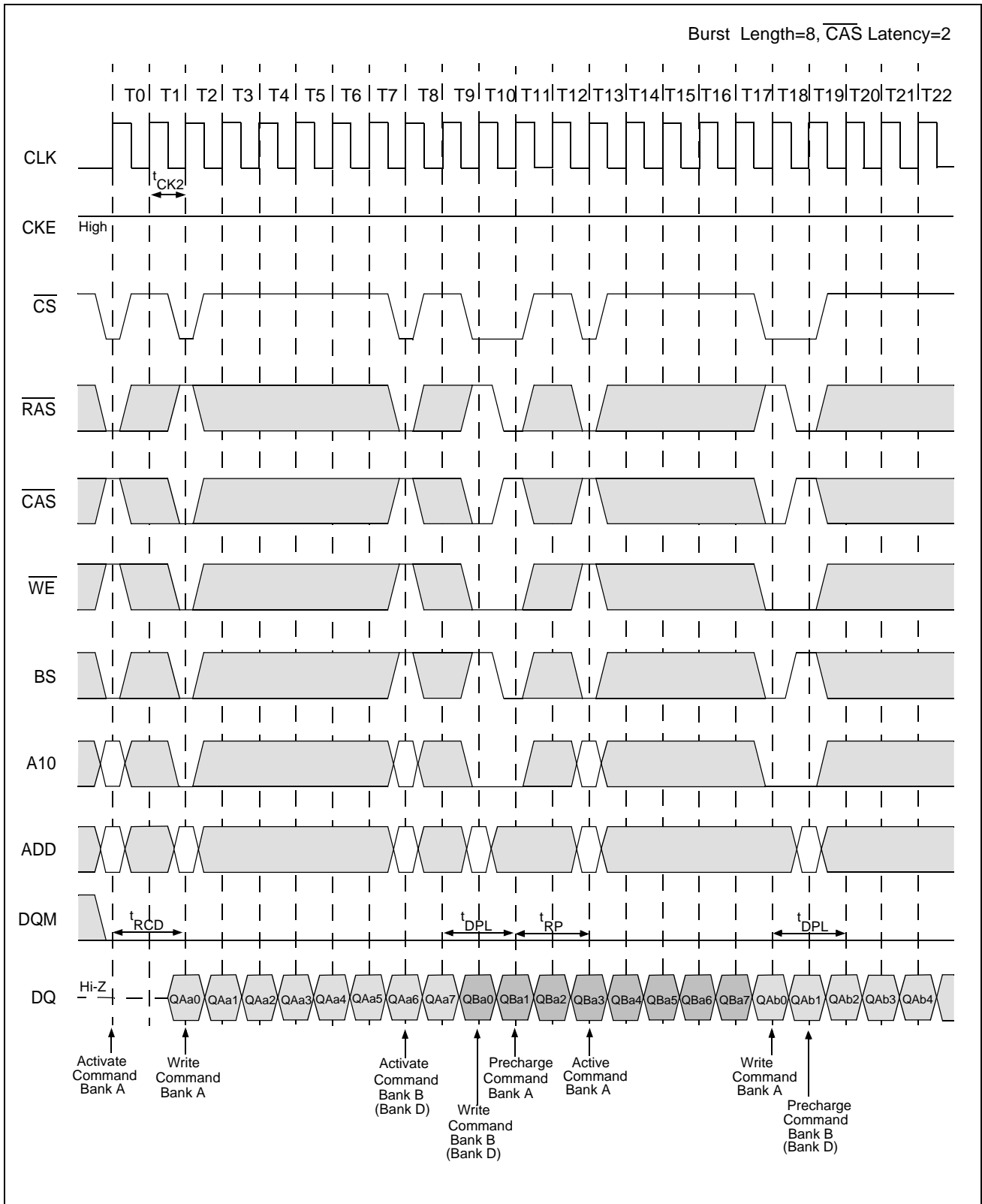



Random Row Write (Interleaving Banks) (2 of 2)

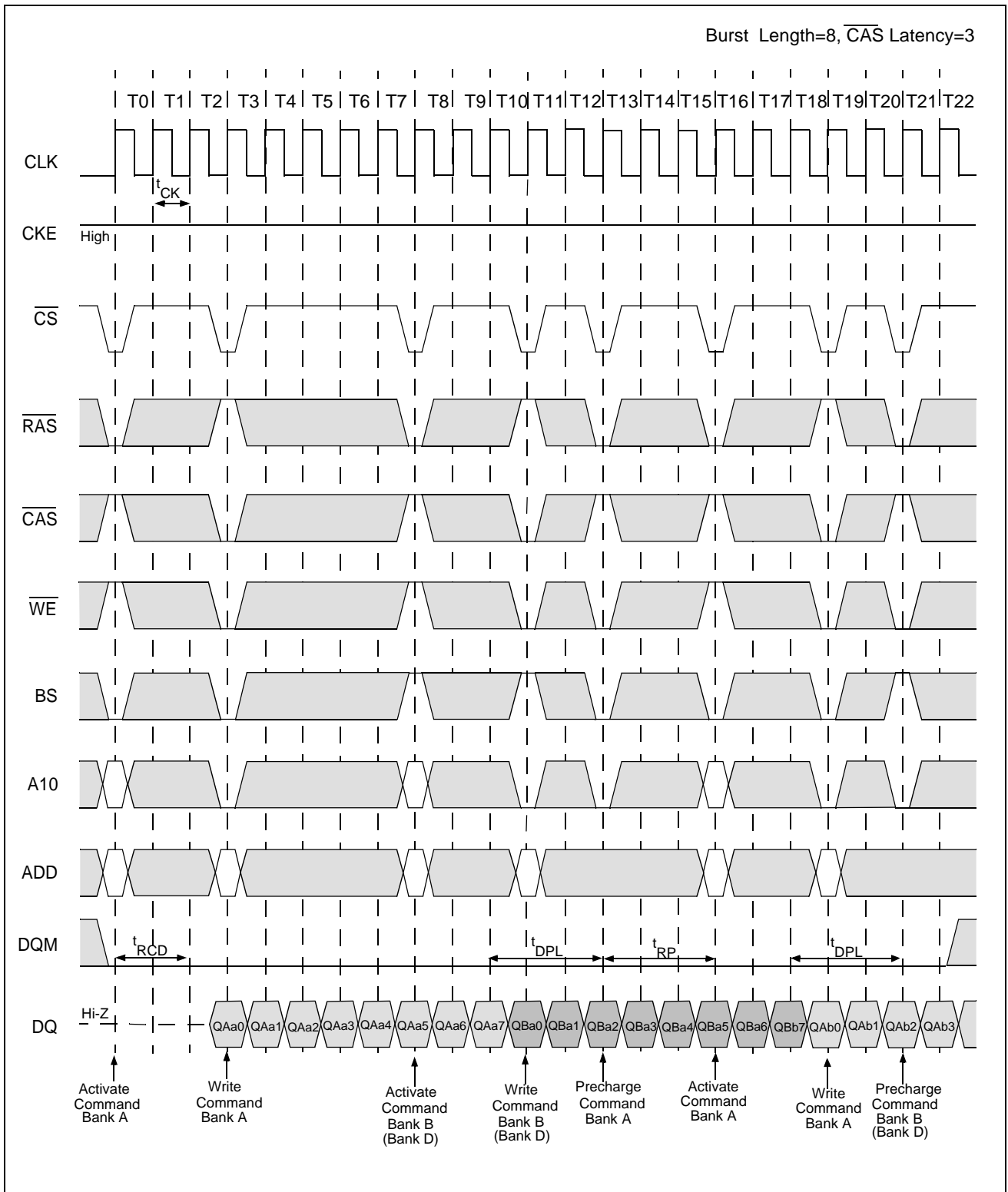

Read and Write Cycle (1 of 2)

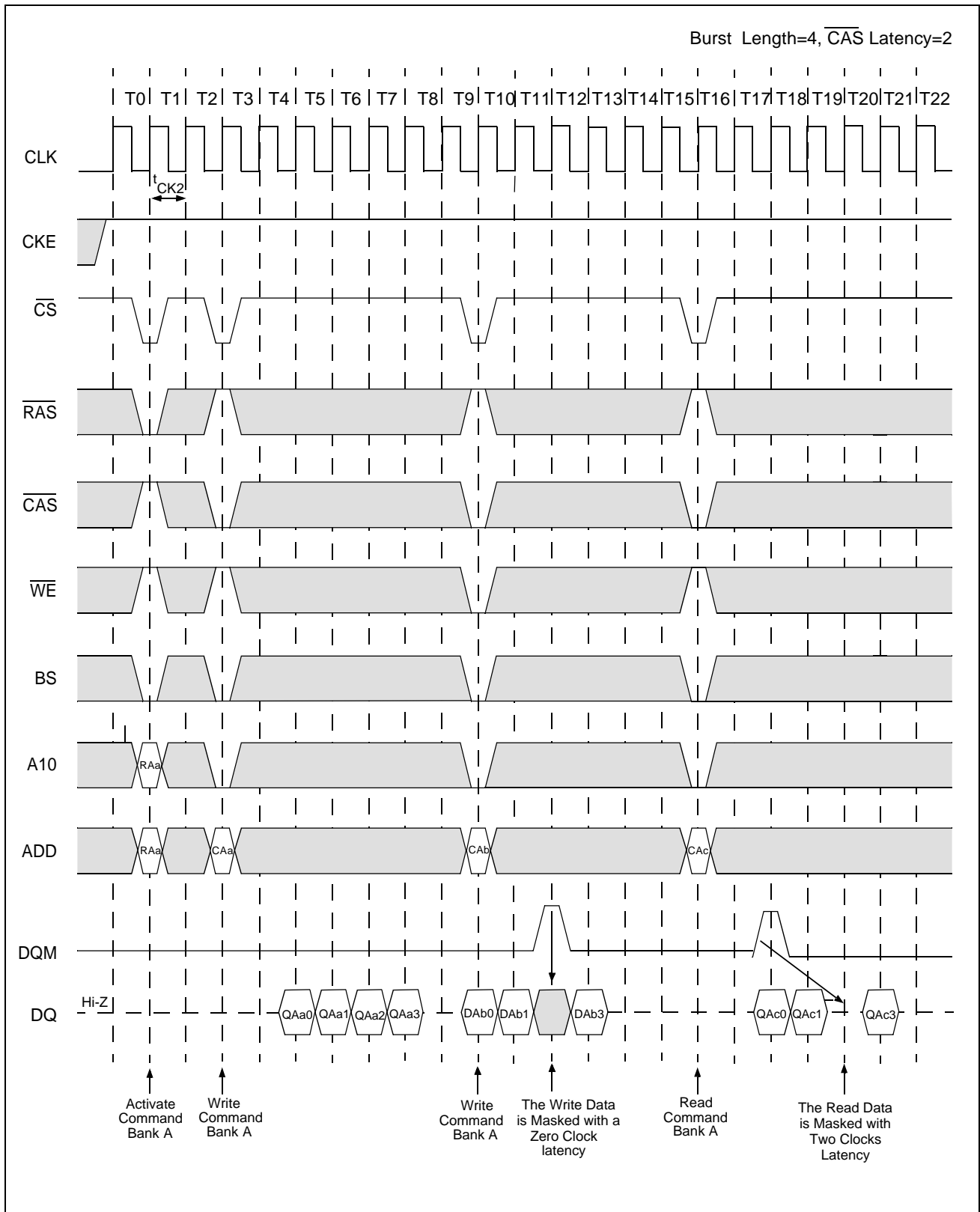

Read and Write Cycle (2 of 2)

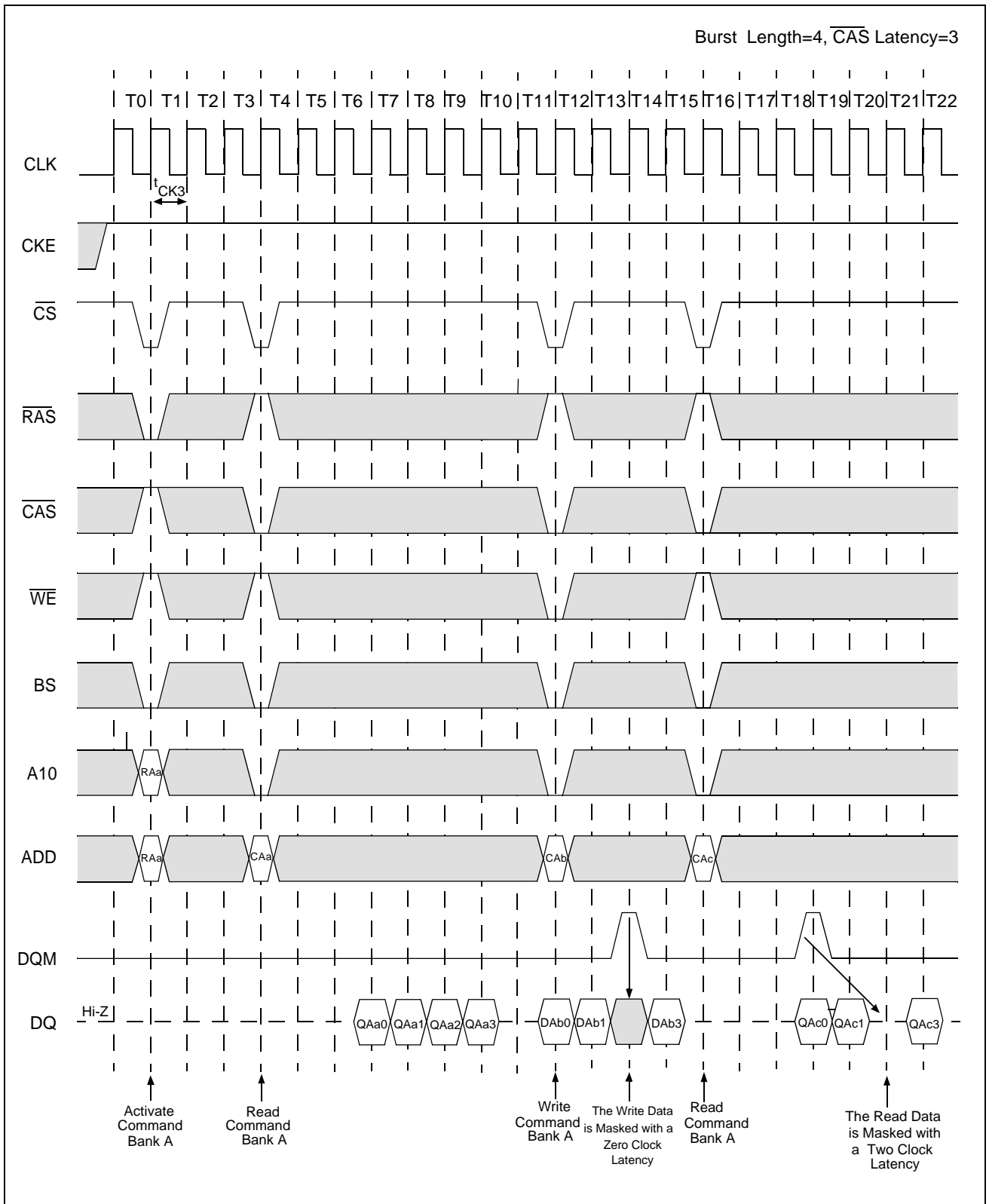

Interleaved Column Read Cycle (1 of 2)

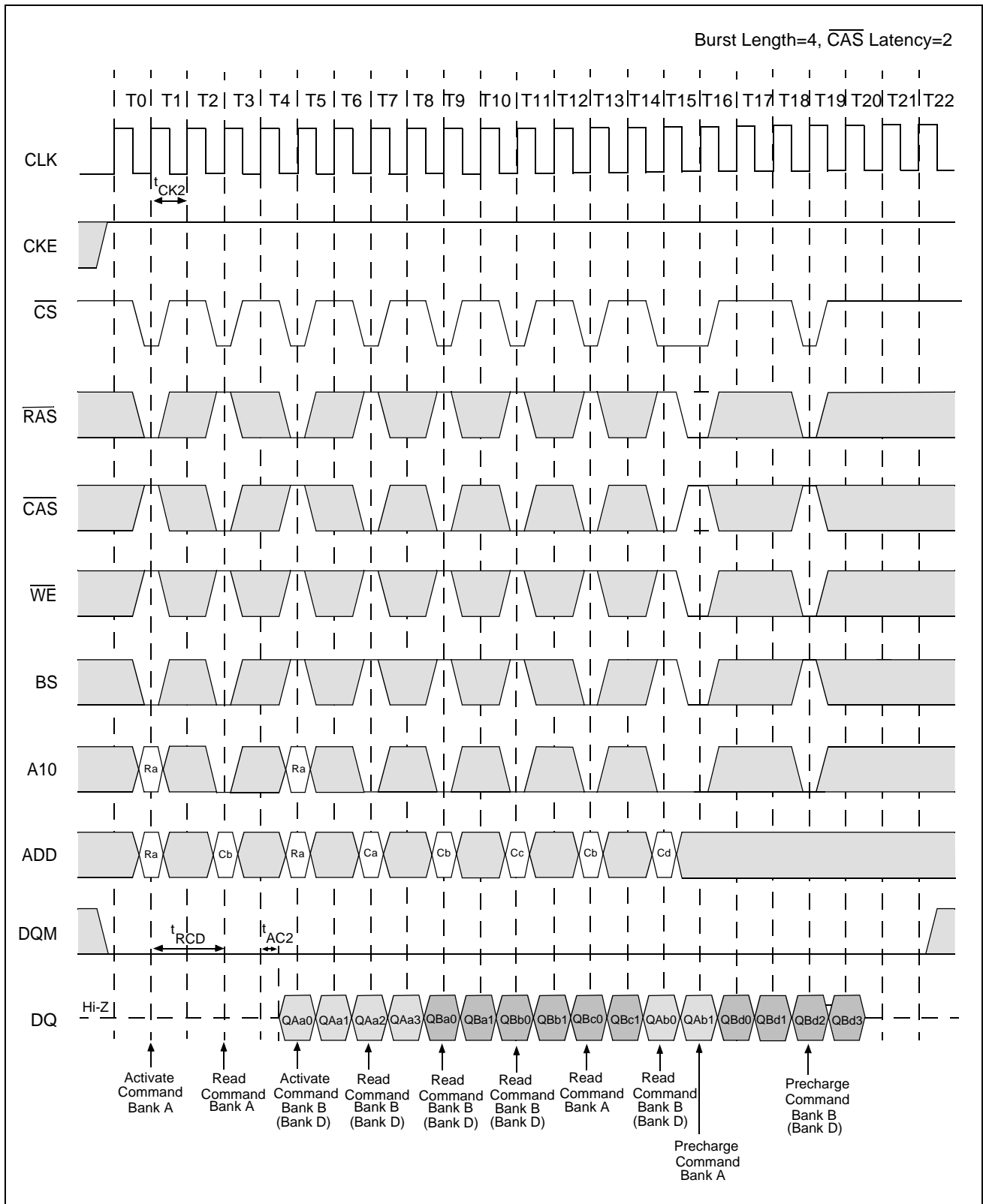

Interleaved Column Read Cycle (2 of 2)

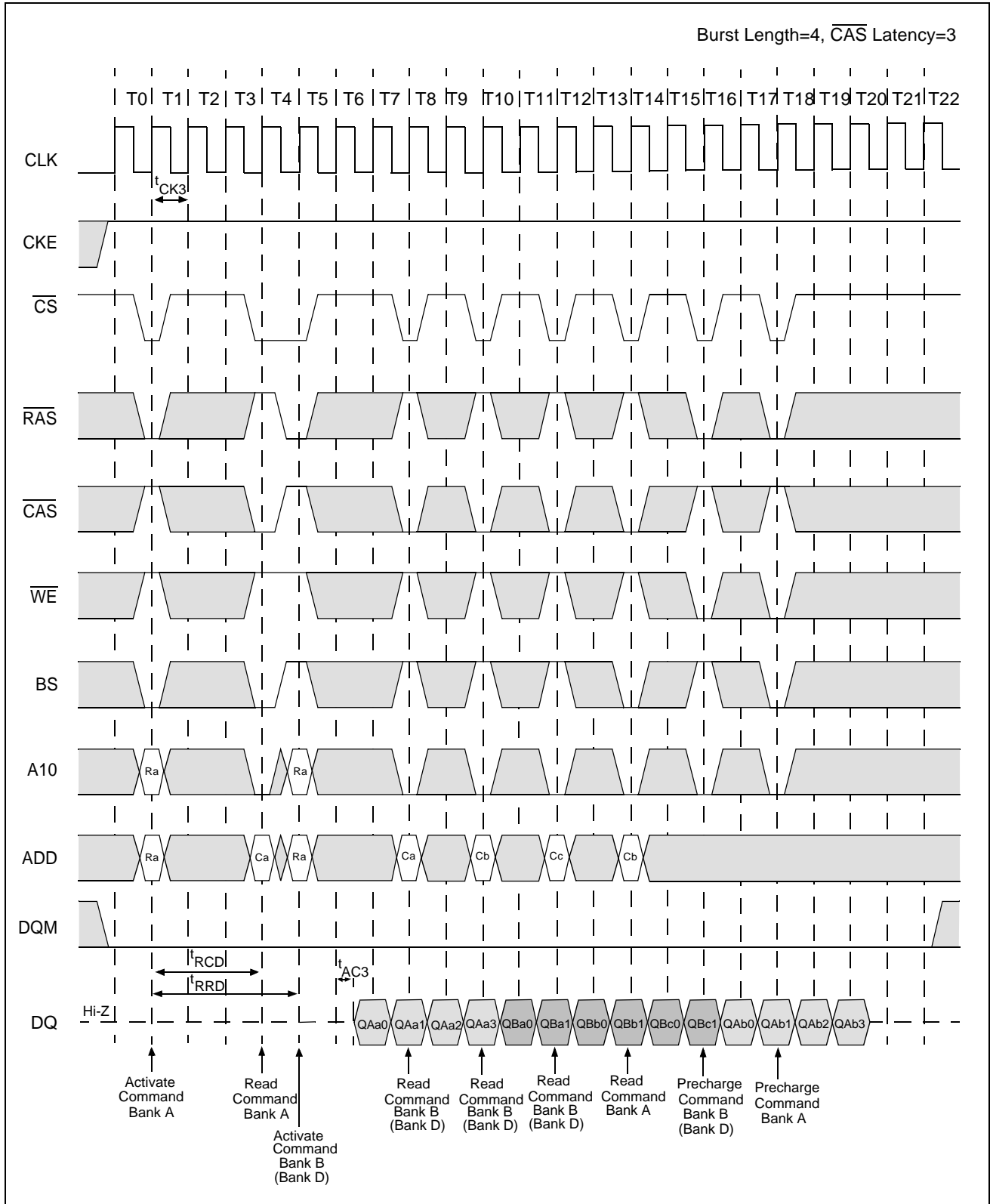

Interleaved Column Write Cycle (1 of 2)

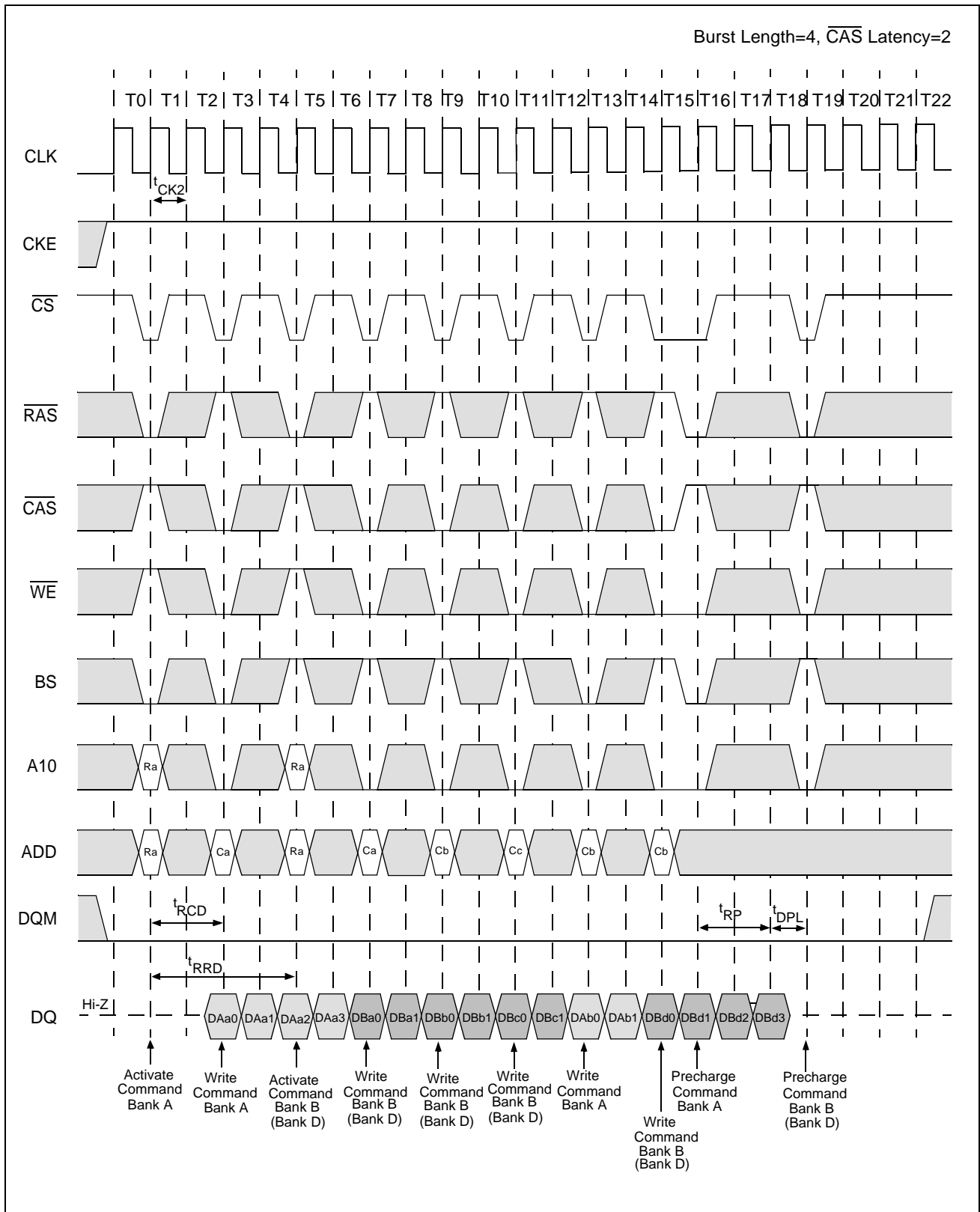

Interleaved Column Write Cycle (2 of 2)

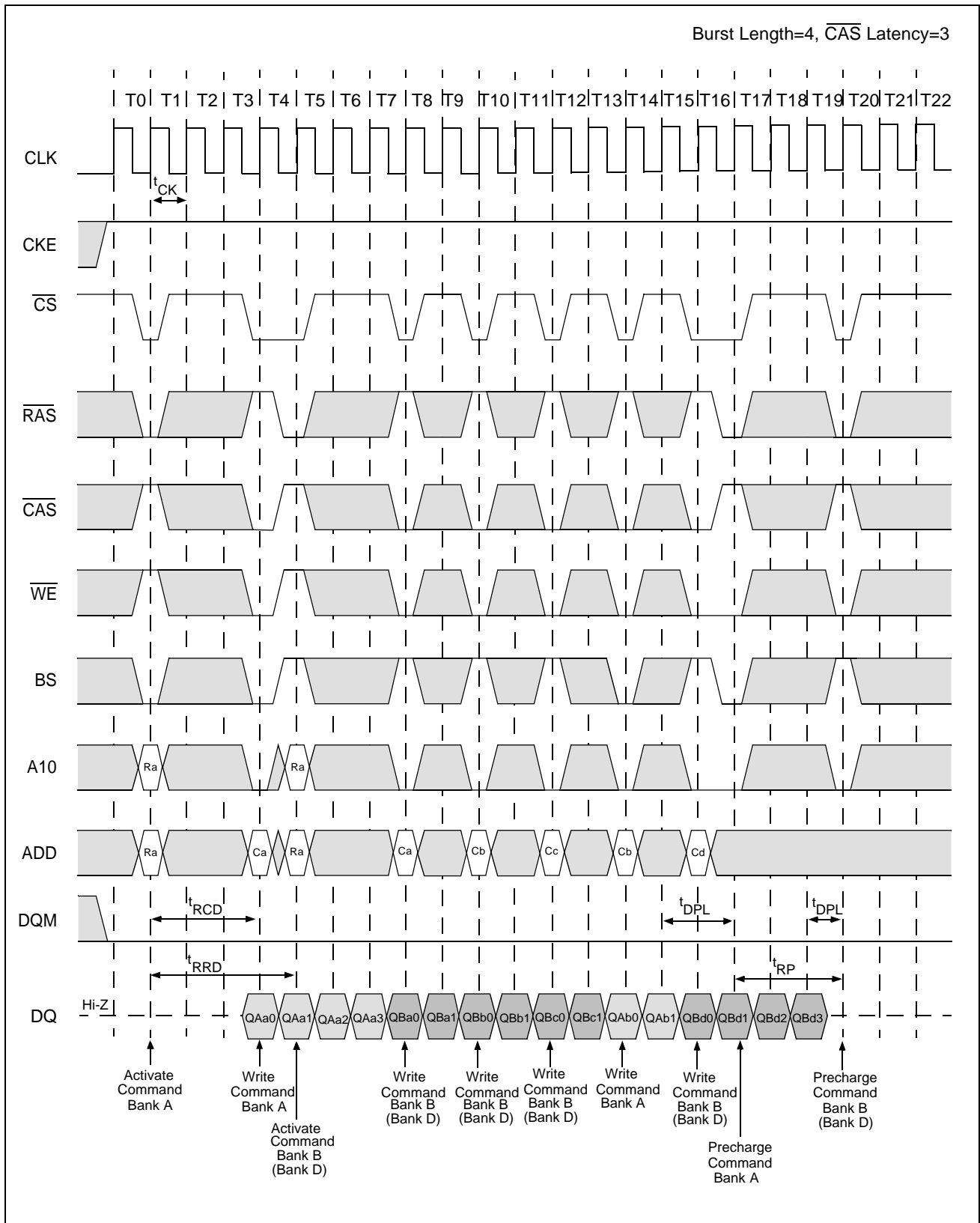

Auto Precharge after Read Burst (1 of 2)

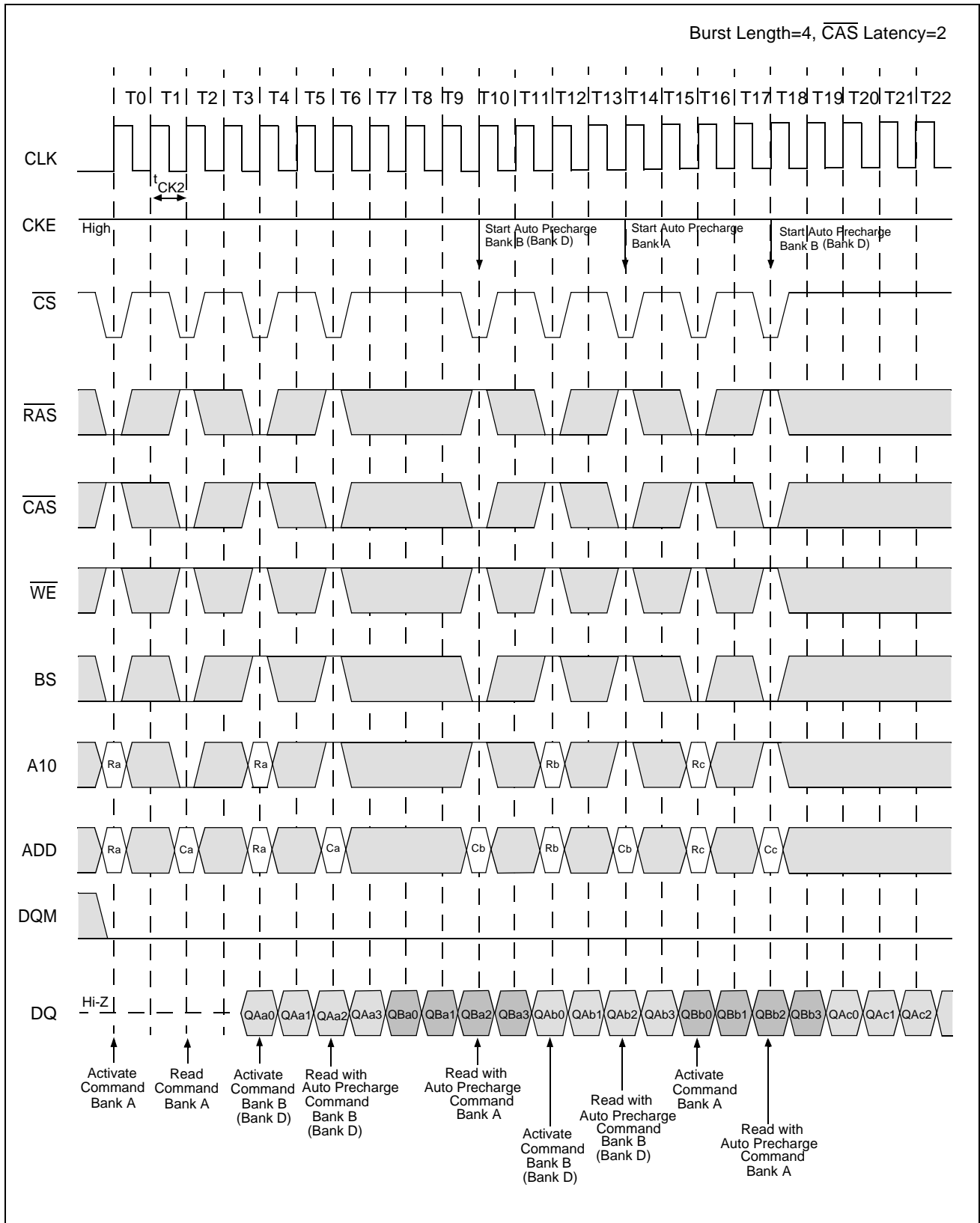



Auto Precharge after Write Burst (2 of 2)

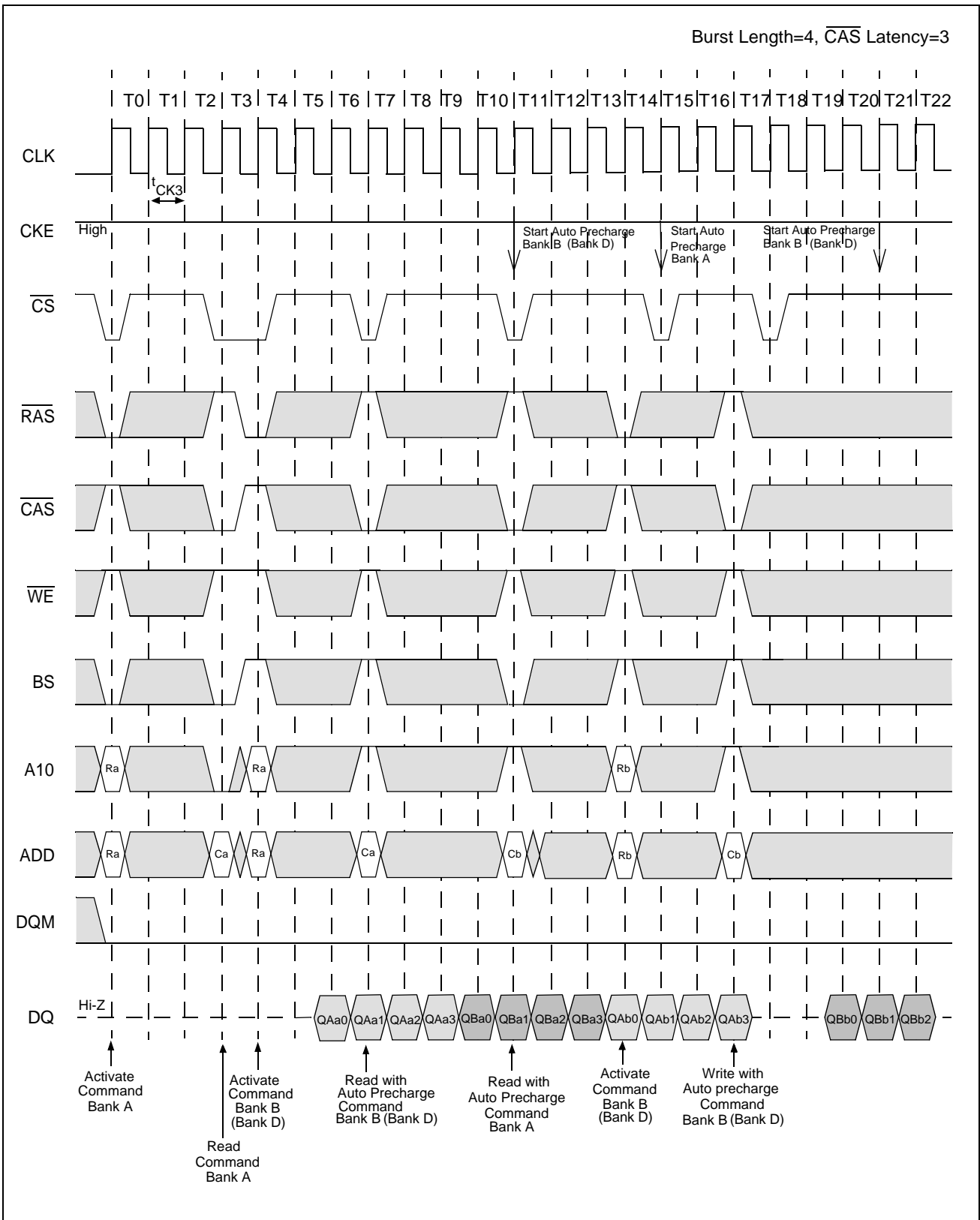

Auto Precharge after Write Burst (1 of 2)

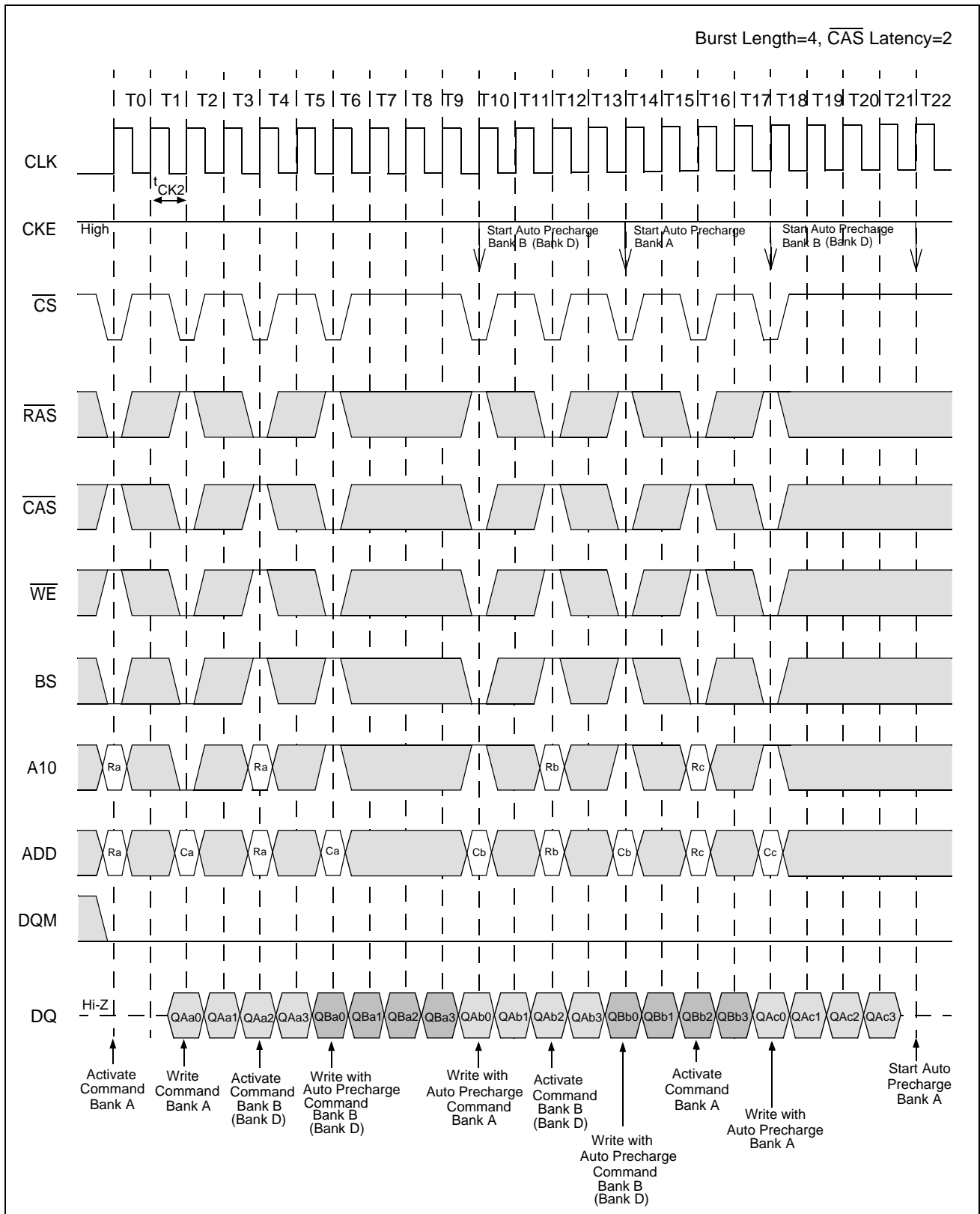

Auto Precharge after Write Burst (2 of 2)

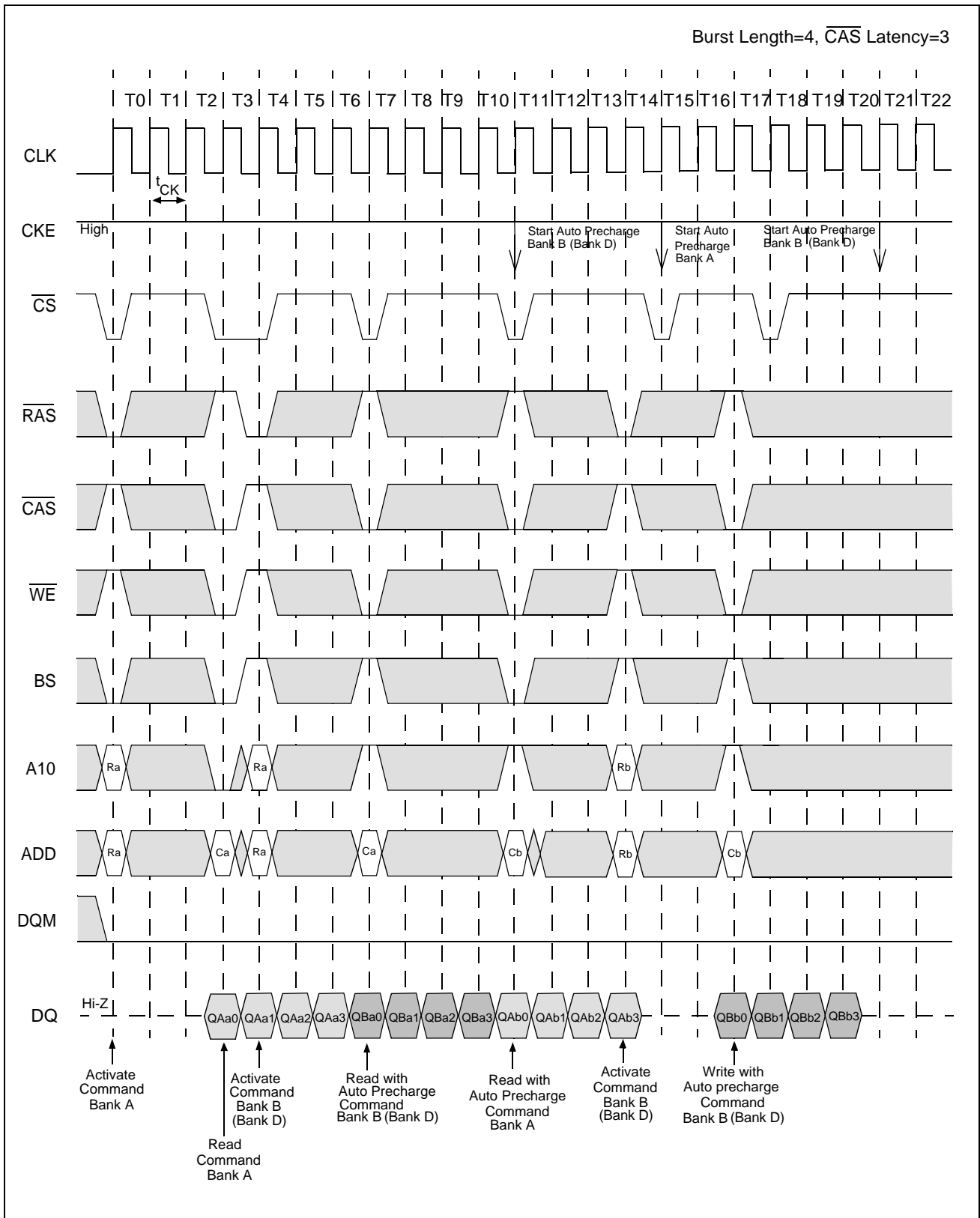

Full Page Read Cycle (1 of 2)

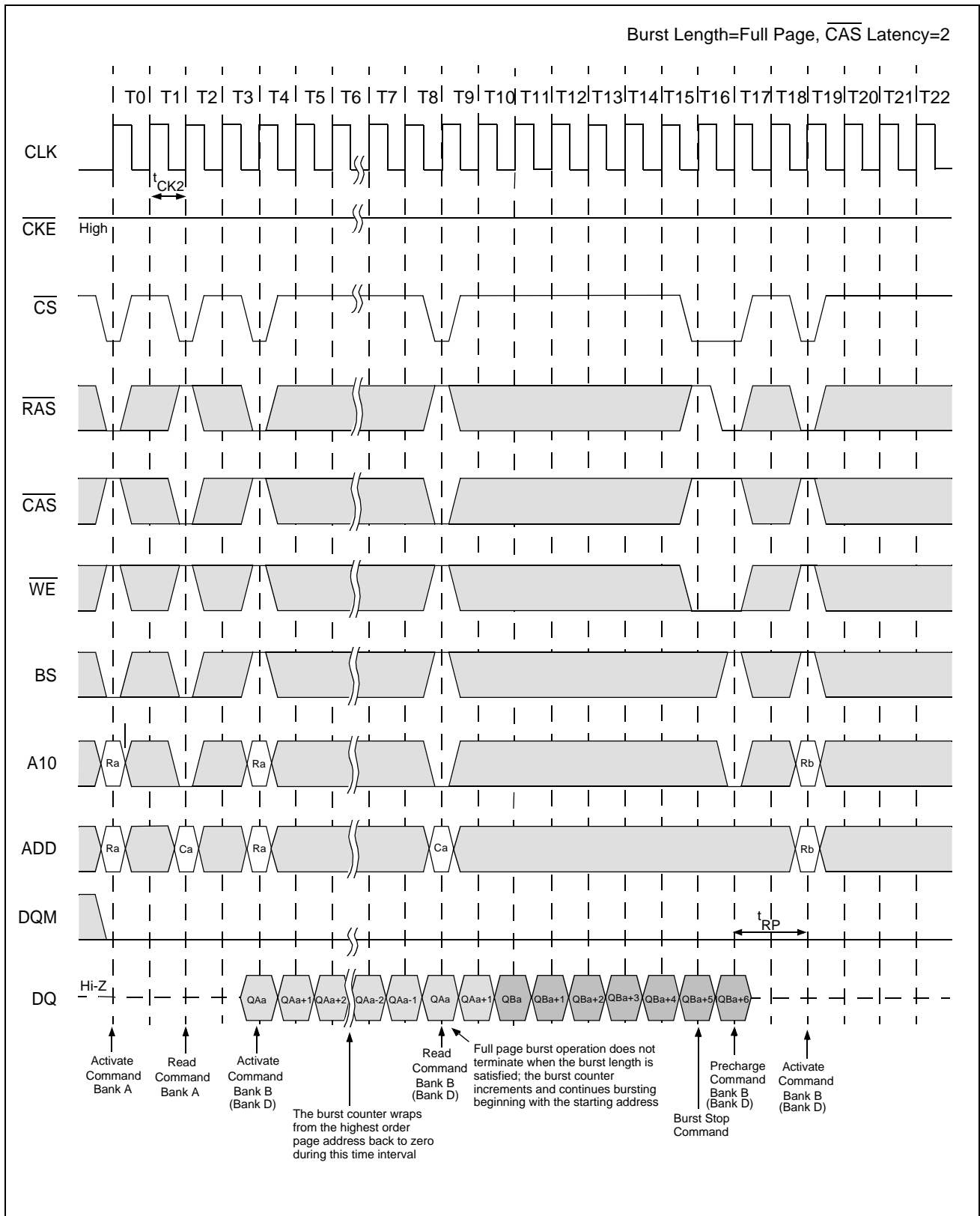

Full Page Read Cycle (2 of 2)

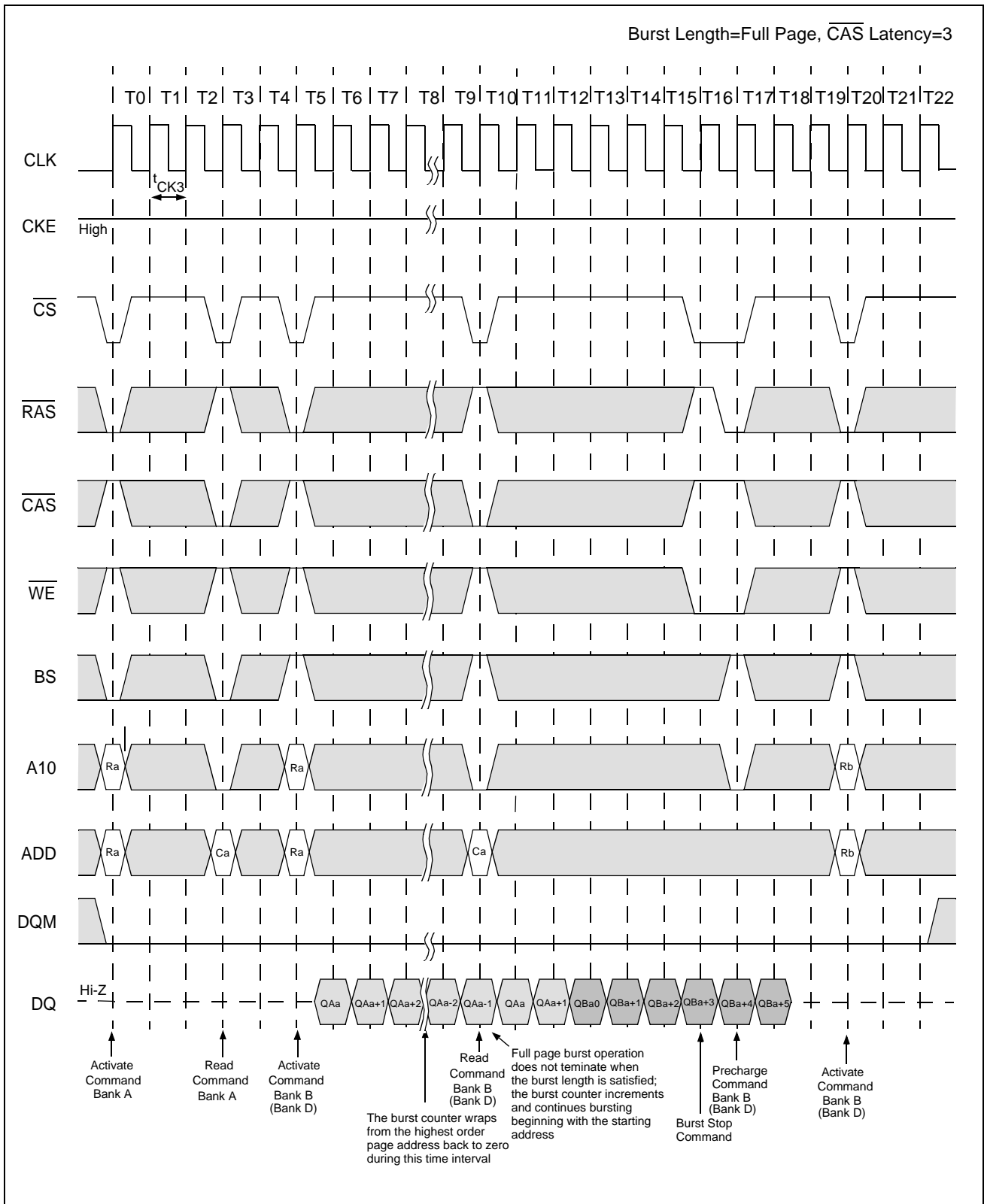

Full Page Write Cycle (1 of 2)

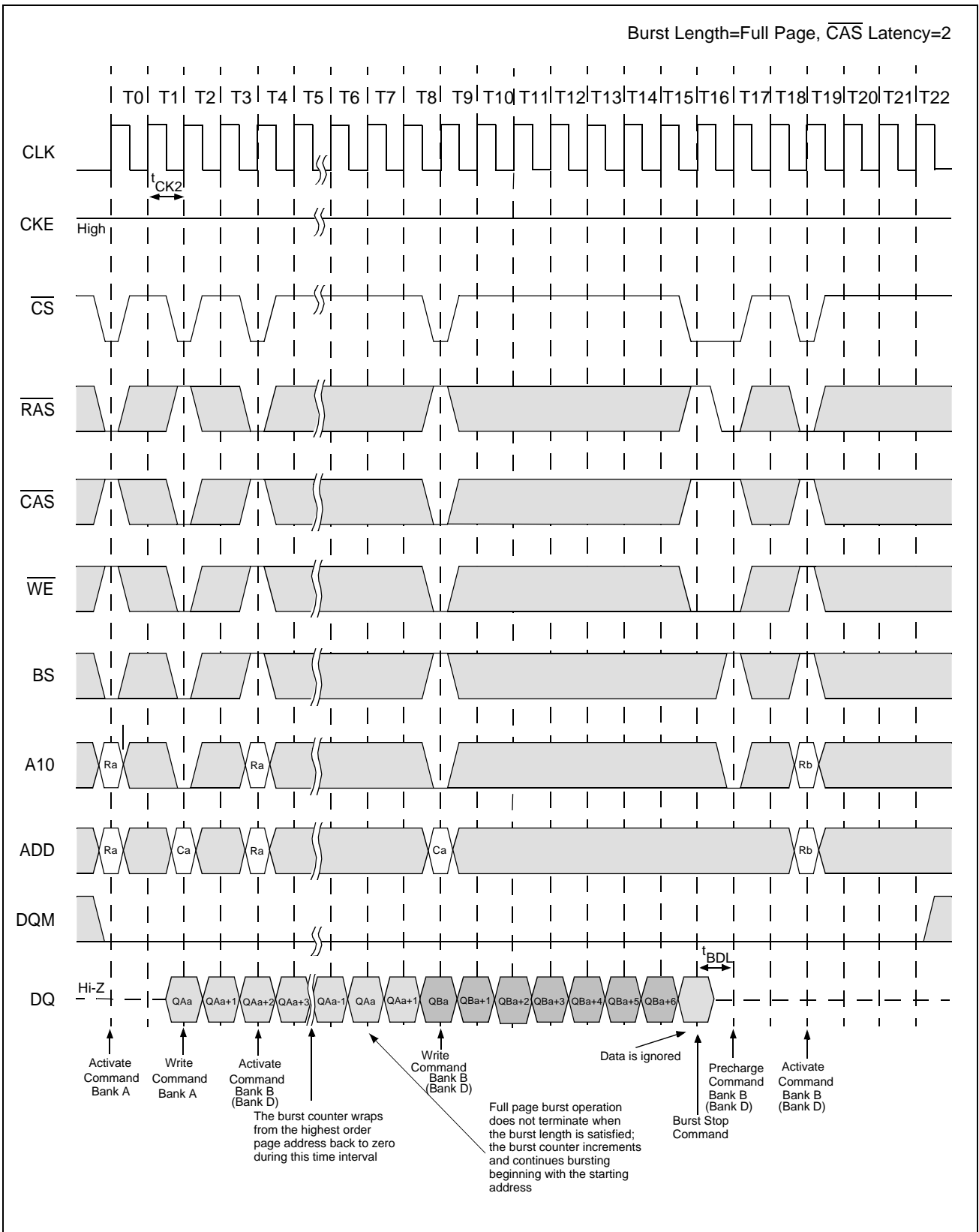

Full Page Write Cycle (2 of 2)

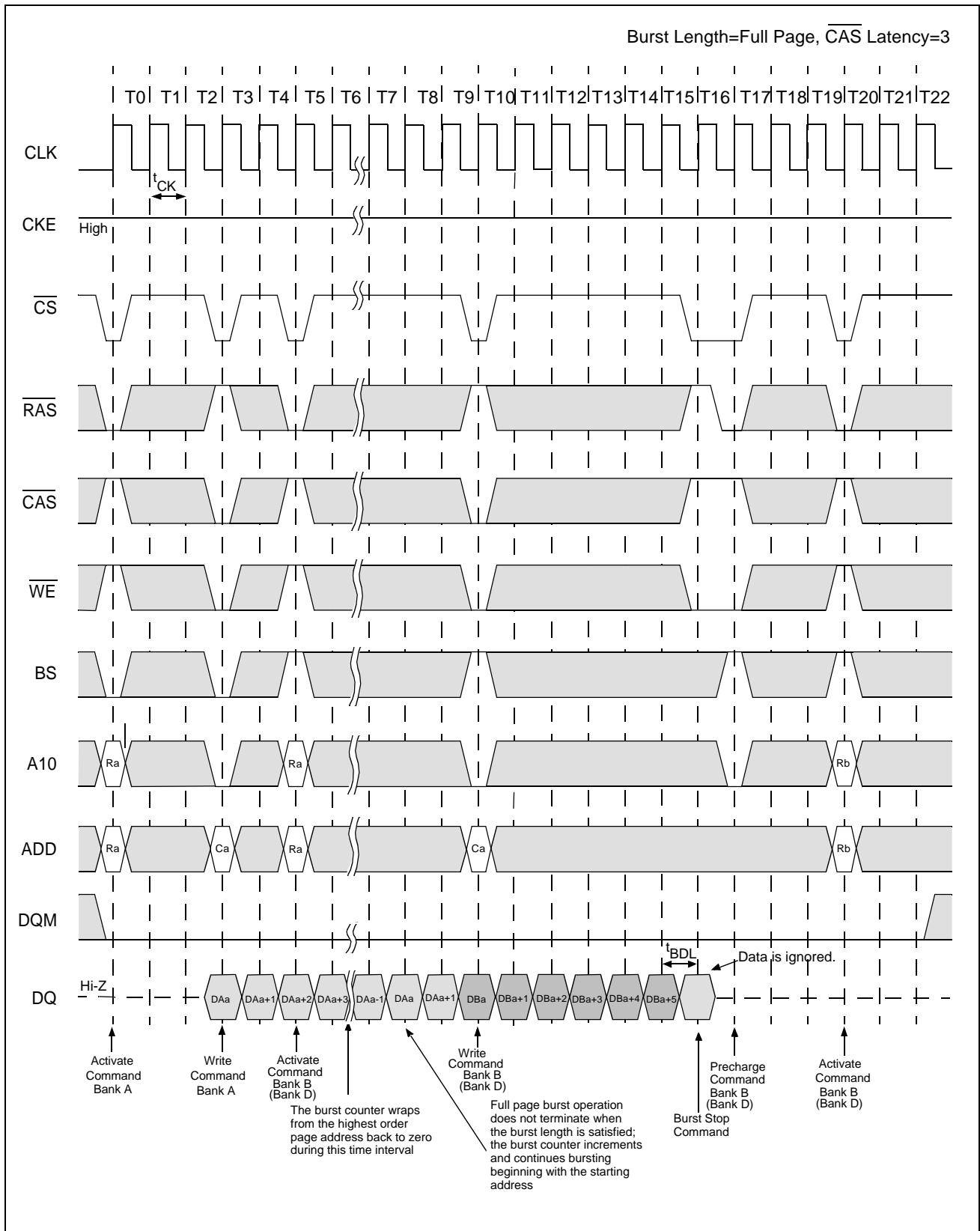

Byte Write Operation

Burst Length = 4, CAS Latency = 2

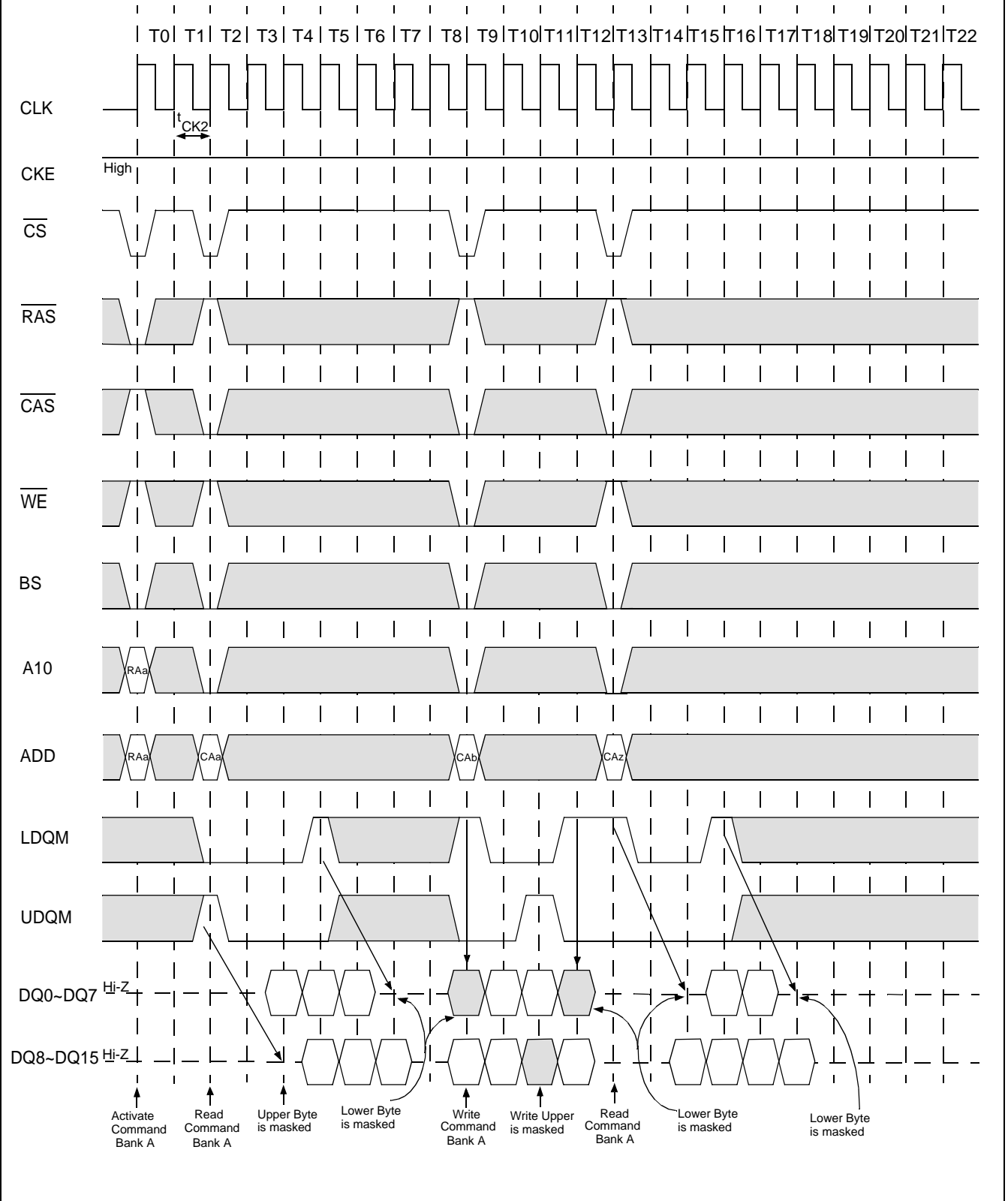



Burst Read and Single Write Operation

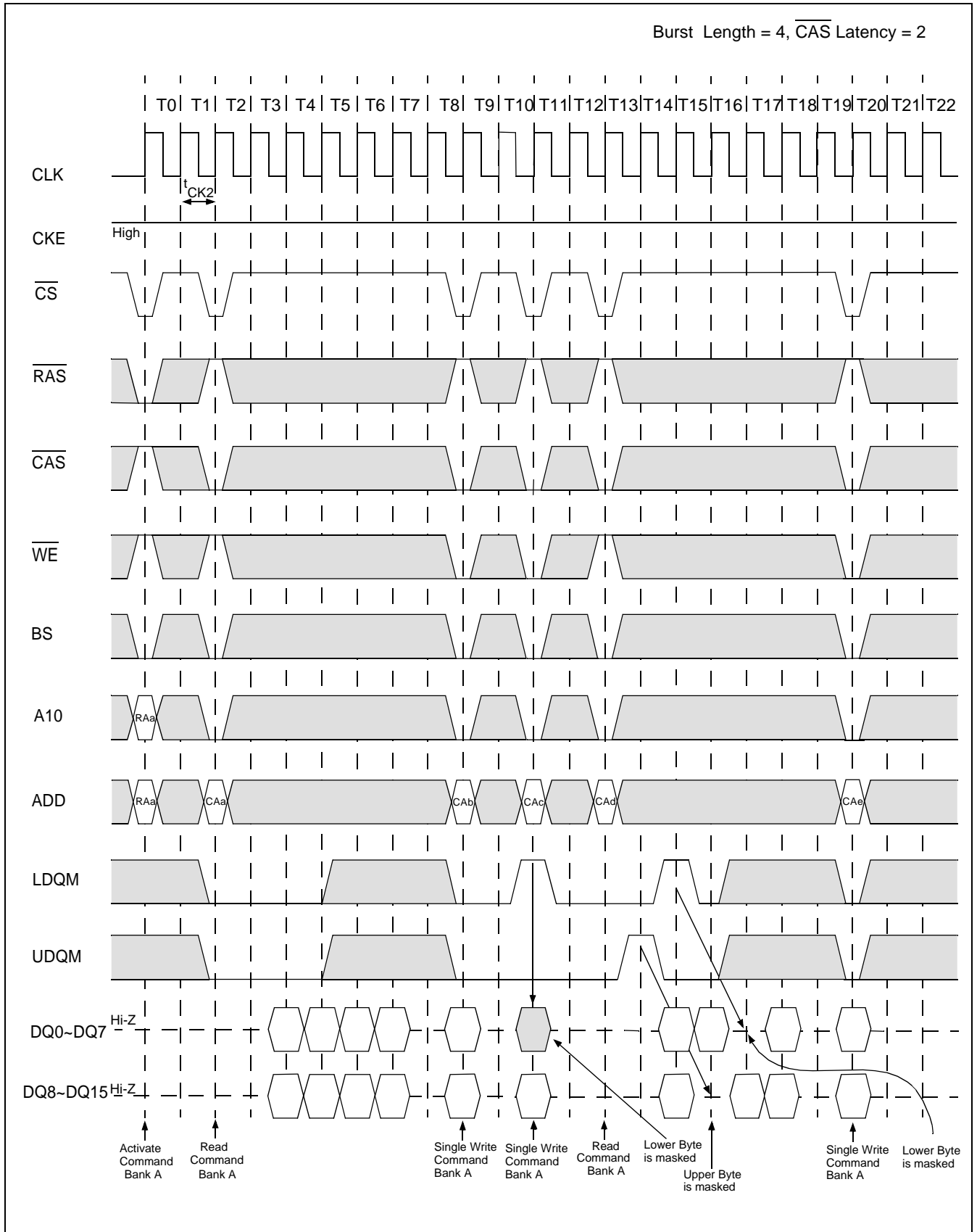

Full Page Random Column Read

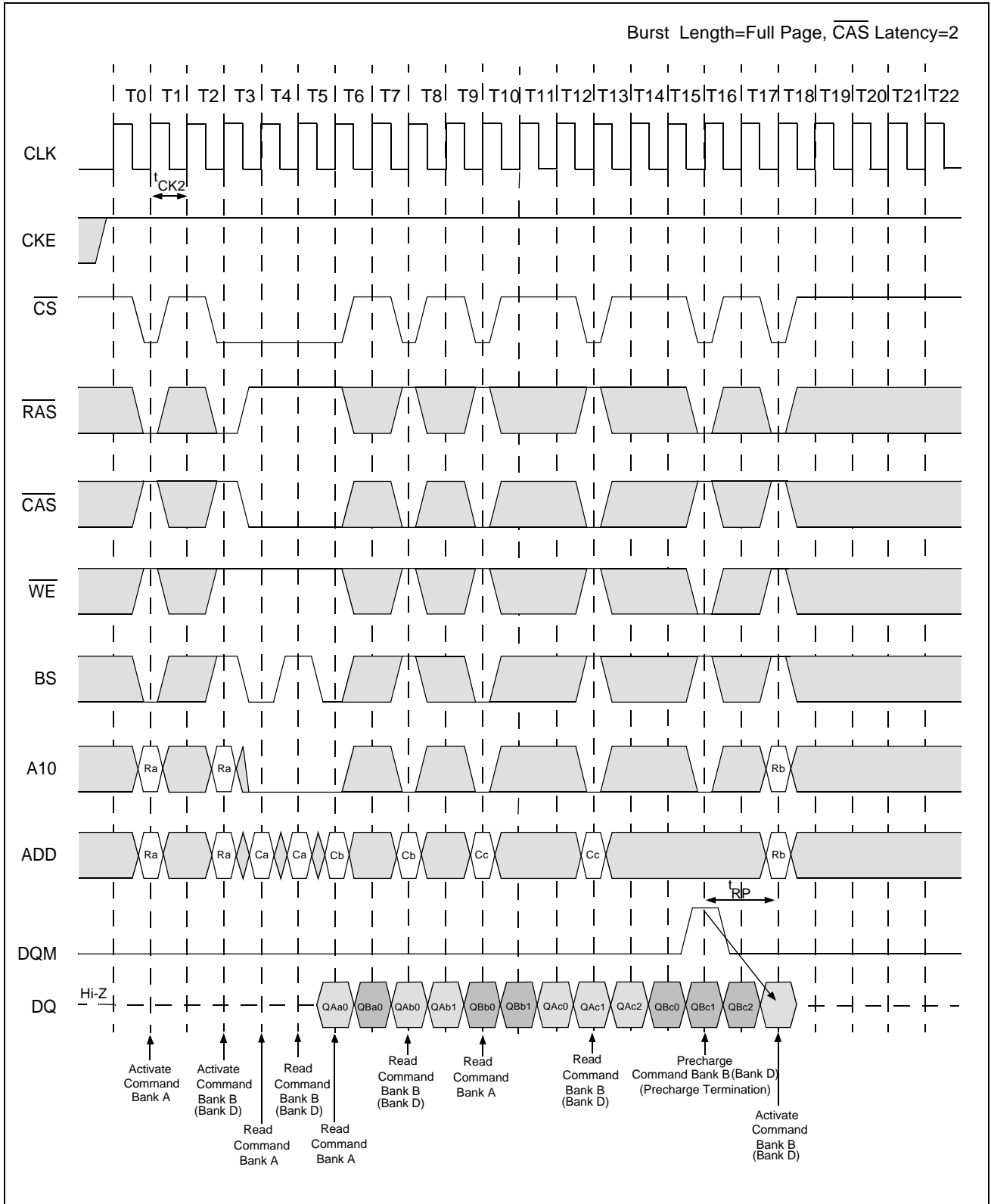

Full Page Random Column Write

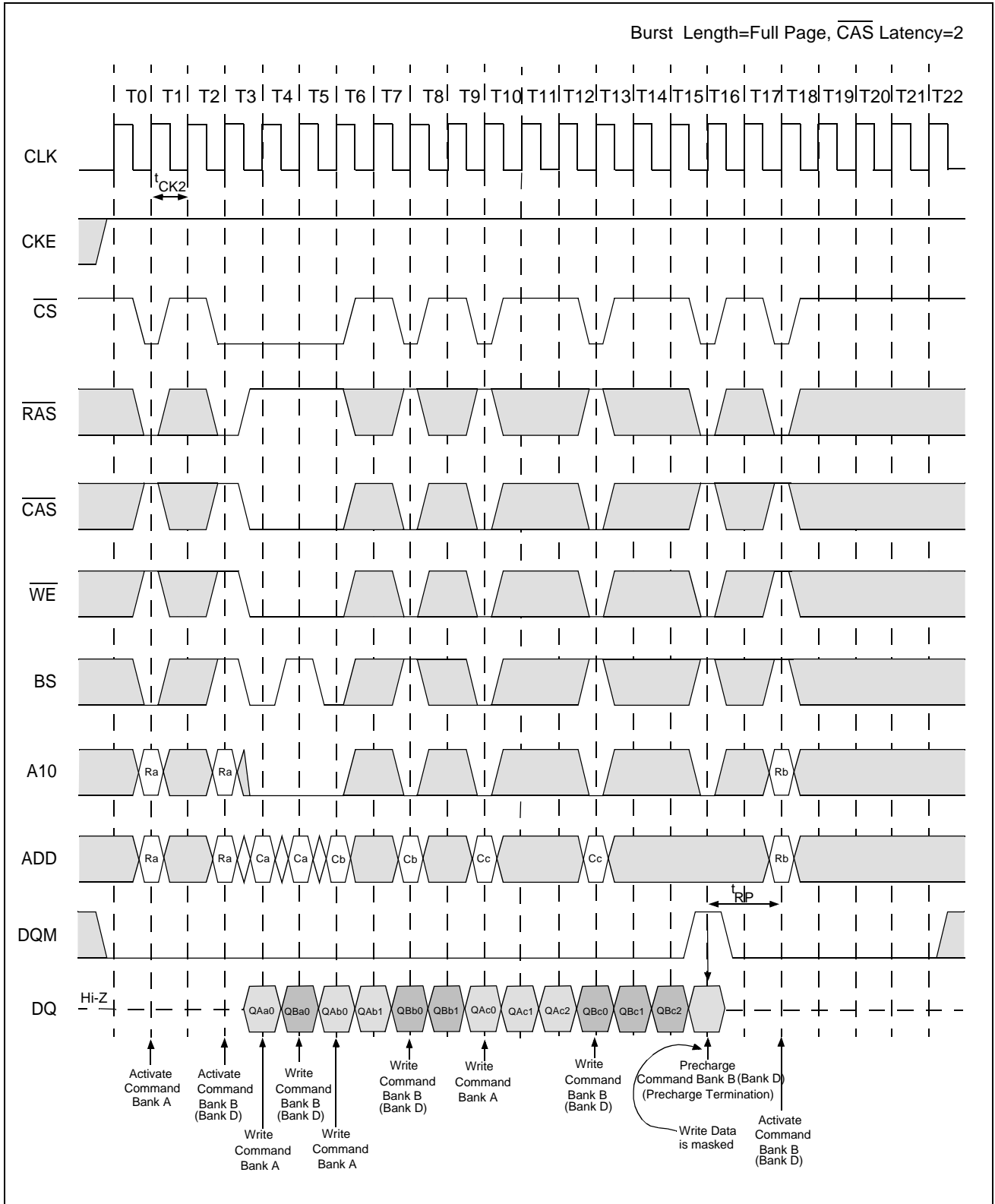

Precharge Termination of a Burst (1 of 2)

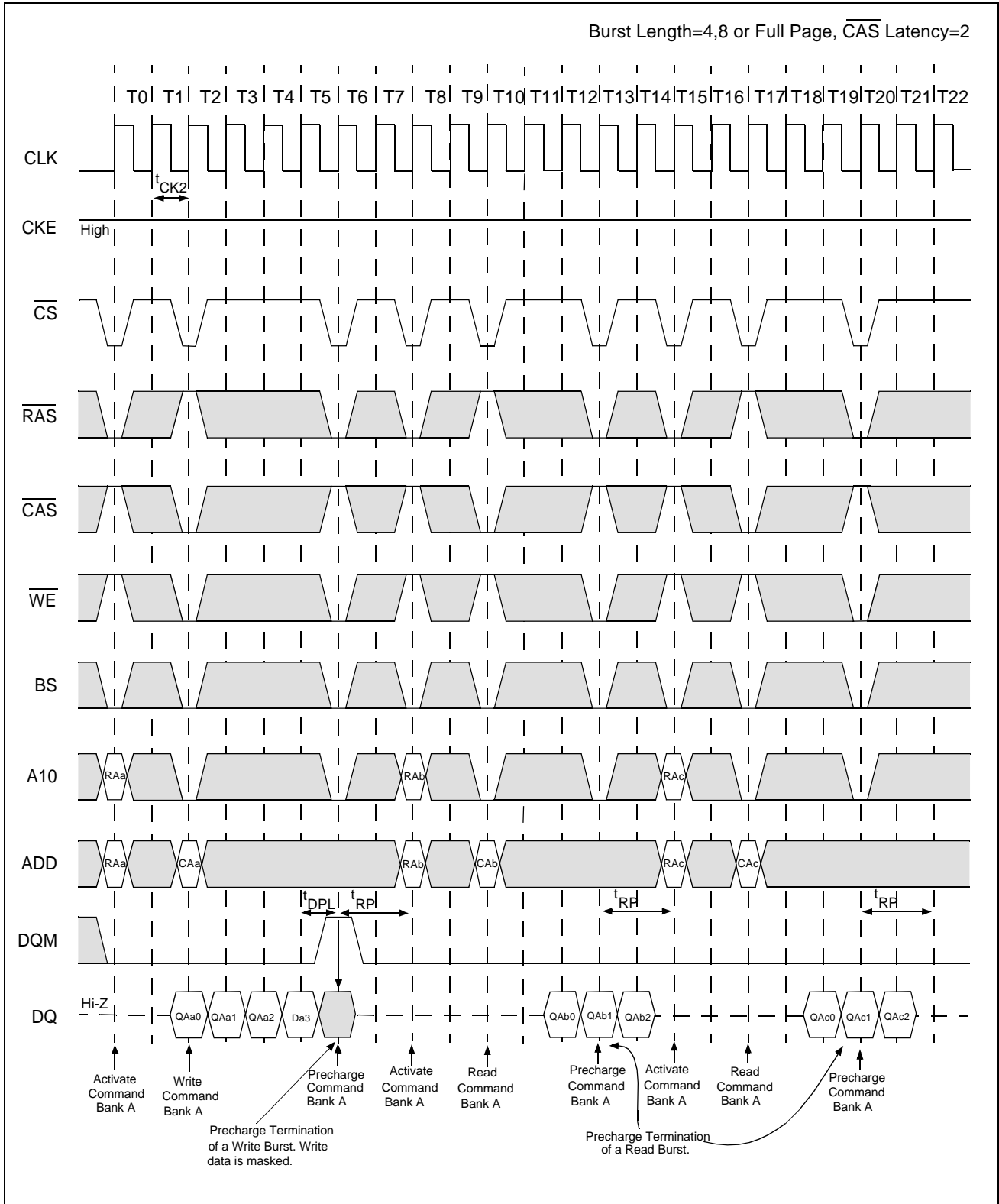

Precharge Termination of a Burst (2 of 2)

