

LM386-1

Low Voltage Audio Power Amplifier

General Description

The LM386-1 is a power amplifier designed for use in low voltage consumer applications. The gain is internally set to 20 to keep external part count low, but the addition of an external resistor and capacitor between pins 1 and 8 will increase the gain to any value from 20 to 200.

The inputs are ground referenced while the output automatically biases to one-half the supply voltage. The quiescent power drain is only 24 milliwatts when operating from a 6 volt supply, making the WS386M-1 ideal for battery operation

Features

- Battery operation
- Minimum external parts
- Wide supply voltage range: 4V–12V
- Low quiescent current drain: 4mA
- Voltage gains from 20 to 200
- Ground referenced input
- Self-centering output quiescent voltage
- Low distortion: 0.2% ($A_V = 20$, $V_S = 6V$, $R_L = 8\Omega$, $P_O = 125mW$, $f = 1kHz$)
- Available in 8 pin SOP package and DIP package

Applications

- AM-FM radio amplifiers
- Portable tape player amplifiers
- Intercoms
- TV sound systems
- Line drivers
- Ultrasonic drivers
- Small servo drivers
- Power converters

Ordering Information

PART NO.	PACKAGE
LM386M-1	SOP-8
LM386N-1	DIP-8

Equivalent Schematic and Connection Diagrams

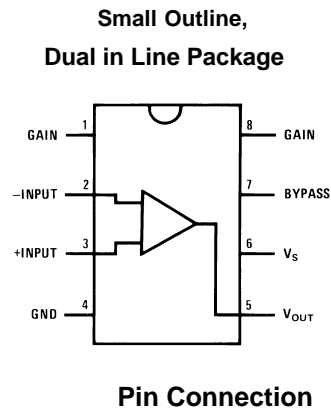
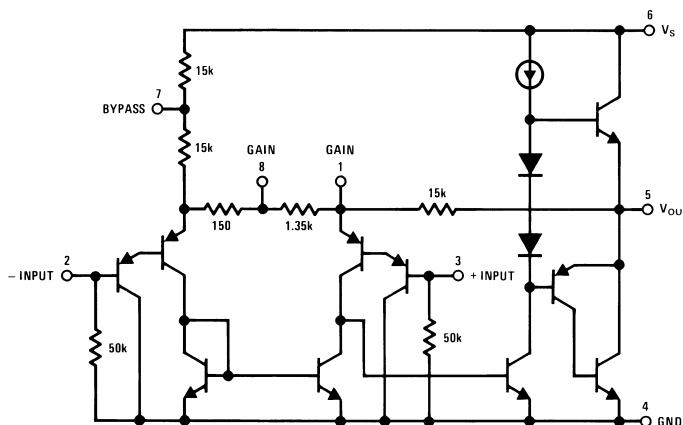

LM386-1

Absolute Maximum Ratings

Supply Voltage (WS386-1)	15V
Package Dissipation(Note3) (WS386N)	1.25W
(WS386M)	0.73W
Input Voltage	±4V
Storage Temperature	- 65 C to +150 C
Operating Temperature	0 C to+70 C
Junction Temperature	+150 C

Soldering Information

Dual-In-Line Package	
Soldering (10 sec)	+260°C
Small Outline Package (SOIC)	
Vapor Phase (60 sec)	+215°C
Infrared (15 sec)	+220°C

Electrical Characteristics (Notes 1, 2)

$T_A = 25^\circ\text{C}$, $V_{CC}=6\text{V}$, $R=8$, $f=1\text{KHz}$ unless otherwise specified

Parameter	Conditions	Min	Typ	Max	Units
Operating Supply Voltage (V_S)		4		12	V
Quiescent Current (I_Q)	$V_S = 6\text{V}$, $V_{IN} = 0$		4	8	mA
Output Power (P_{OUT})	$V_S = 6\text{V}$, $R_L = 8\Omega$, THD = 10% $V_S = 9\text{V}$, $R_L = 8$, THD = 10%	250 50	325 700		mW
Bandwidth (BW)	$V_S = 6\text{V}$, 10uF from Pin 1 to 8		60		kHz
Voltage Gain (A_v)	$V_S = 6\text{V}$, $f = 1\text{ kHz}$ Pins 1 and 8 Open 10 μF from Pin 1 to 8		26 46		dB dB
Bandwidth (BW)	$V_S = 6\text{V}$, Pins 1 and 8 Open		300		kHz
Total Harmonic Distortion (THD)	$V_S = 6\text{V}$, $R_L = 8\Omega$, $P_{OUT} = 125\text{ mW}$ $f = 1\text{ kHz}$, Pins 1 and 8 Open		0.2		%
Power Supply Rejection Ratio (PSRR)	$V_S = 6\text{V}$, $f = 1\text{ kHz}$, $C_{BYPASS} = 10\ \mu\text{F}$ Pins 1 and 8 Open, Referred to Output		50		dB
Input Resistance (R_{IN})			50		k Ω
Input Bias Current (I_{BIAS})	$V_S = 6\text{V}$, Pins 2 and 3 Open		250		nA

Note 1: All voltages are measured with respect to the ground pin, unless otherwise specified.

Note 2: Absolute Maximum Ratings indicate limits beyond which damage to the device may occur. Operating Ratings indicate conditions for which the device is functional, but do not guarantee specific performance limits. Electrical Characteristics state DC and AC electrical specifications under particular test conditions which guarantee specific performance limits. This assumes that the device is within the Operating Ratings. Specifications are not guaranteed for parameters where no limit is given, however, the typical value is a good indication of device performance.

Note 3: For operation in ambient temperatures above 25°C, the device must be derated based on a 150°C maximum junction temperature and a thermal resistance of 170°C/W for the small outline package.

LM386-1

Application Hints

GAIN CONTROL

To make LM386-1 a more versatile amplifier, two pins (1 and 8) are provided for gain control. With pins 1 and 8 open the 1.35 k Ω resistor sets the gain at 20 (26 dB). If a capacitor is put from pin 1 to 8, bypassing the 1.35 k Ω resistor, the gain will go up to 200 (46 dB). If a resistor is placed in series with the capacitor, the gain can be set to any value from 20 to 200. Gain control can also be done by capacitively coupling a resistor (or FET) from pin 1 to ground.

Additional external components can be placed in parallel with the internal feedback resistors to tailor the gain and frequency response for individual applications. For example, we can compensate poor speaker bass response by frequency shaping the feedback path. This is done with a series RC from pin 1 to 5 (paralleling the internal 15 k Ω resistor). For 6 dB effective bass boost: $R \approx 15$ k Ω , the lowest value for good stable operation is $R = 10$ k Ω if pin 8 is open. If pins 1 and 8 are bypassed then R as low as 2 k Ω can be used. This restriction is because the amplifier is only compensated for closed-loop gains greater than 9.

INPUT BIASING

The schematic shows that both inputs are biased to ground with a 50 k Ω resistor. The base current of the input transistors is about 250 nA, so the inputs are at about 12.5 mV when left open. If the dc source resistance driving the LM386 is higher than 250 k Ω it will contribute very little additional offset (about 2.5 mV at the input, 50 mV at the output). If the dc source resistance is less than 10 k Ω , then shorting the unused input to ground will keep the offset low (about 2.5 mV at the input, 50 mV at the output). For dc source resistances between these values we can eliminate excess offset by putting a resistor from the unused input to ground, equal in value to the dc source resistance. Of course all offset problems are eliminated if the input is capacitively coupled.

When using LM386-1 with higher gains (bypassing the 1.35 k Ω resistor between pins 1 and 8) it is necessary to bypass the unused input, preventing degradation of gain and possible instabilities. This is done with a 0.1 μ F capacitor or a short to ground depending on the dc source resistance on the driven input.

Pad Location

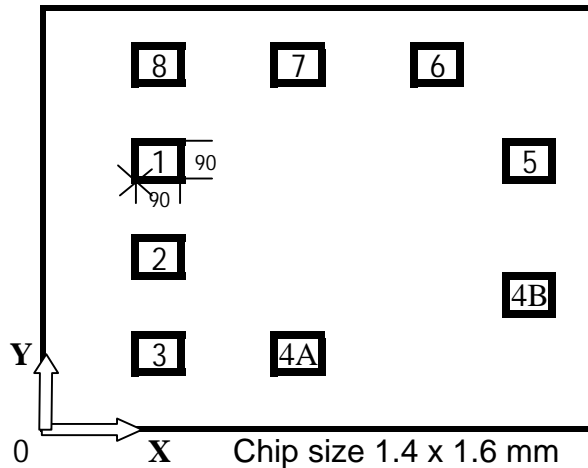

Pad Location Coordinates

Pad N	Pad Name	Coordinates	
		X	Y
1	Gain	120	975
2	-input	120	665
3	+input	120	100
4A	GND	550	100
4B	GND	600	390
5	VOU	600	1015
6	V _{CC}	750	1405
7	BYPASS	440	1405
8	Gain	120	1405

LM386-1

Typical Performance Characteristics

Quiescent Supply Current vs Supply Voltage

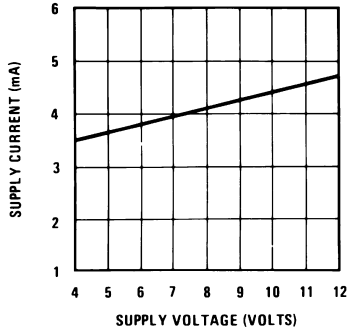

Power Supply Rejection Ratio (Referred to the Output) vs Frequency

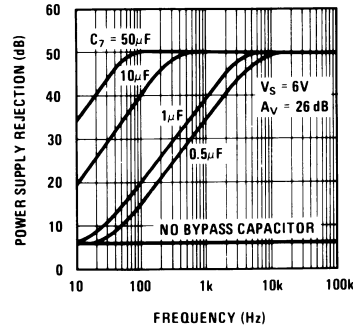

Peak-to-Peak Output Voltage Swing vs Supply Voltage

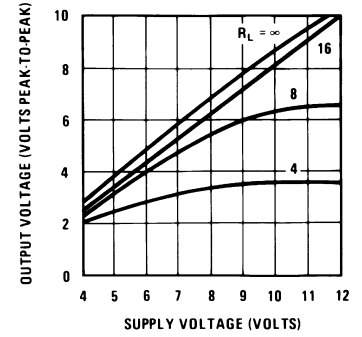

Voltage Gain vs Frequency

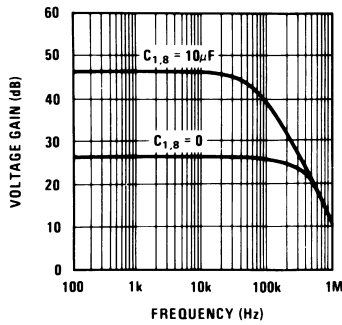

Distortion vs Frequency

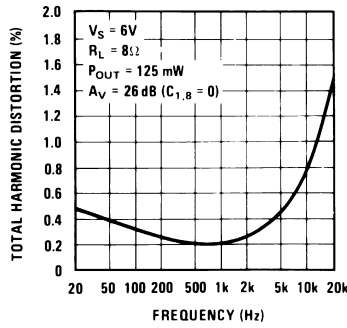

Distortion vs Output Power

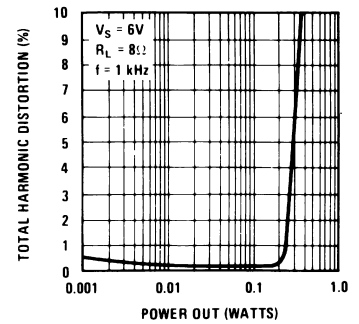

Device Dissipation vs Output Power—4Ω Load

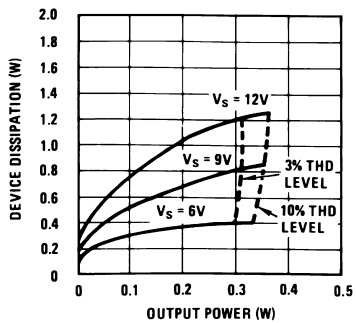

Device Dissipation vs Output Power—8Ω Load

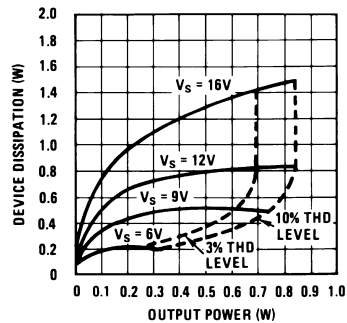

Device Dissipation vs Output Power—16Ω Load

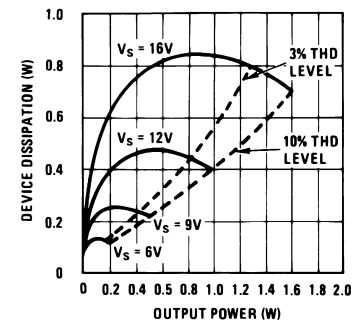

LM386-1

Typical Applications

**Amplifier with Gain = 20
Minimum Parts**

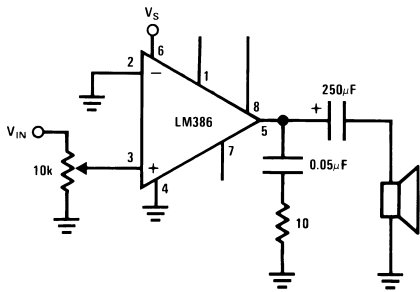

Amplifier with Gain = 200

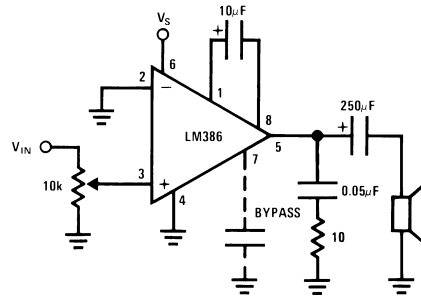

Amplifier with Gain = 50

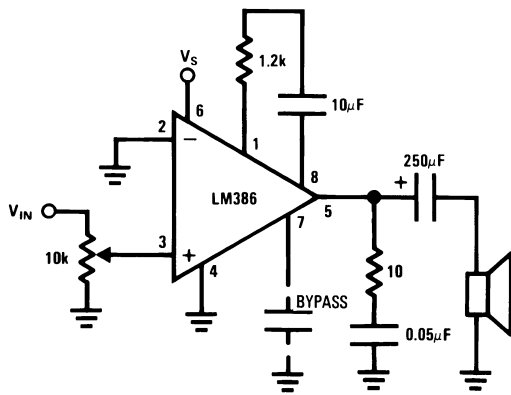

Low Distortion Power Wienbridge Oscillator

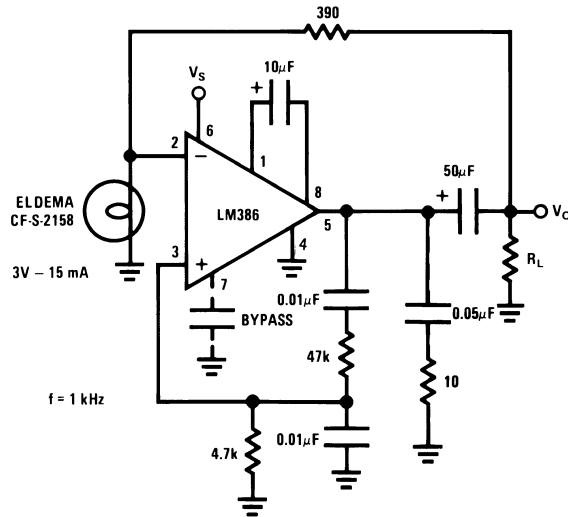

Amplifier with Bass Boost

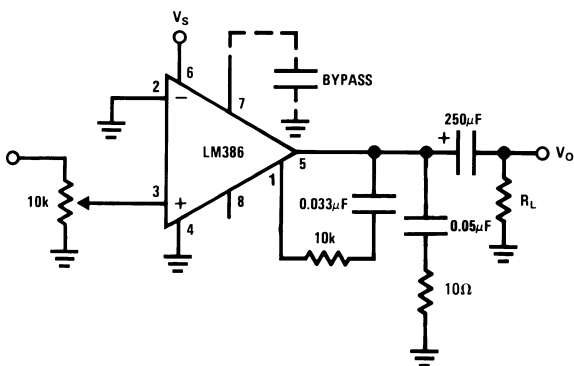

Square Wave Oscillator

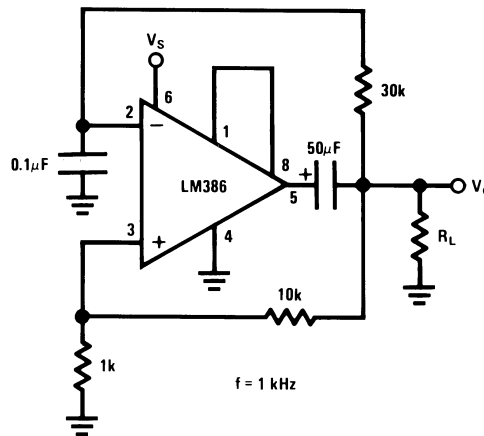

LM386-1

Typical Applications (Continued)

Frequency Response with Bass Boost

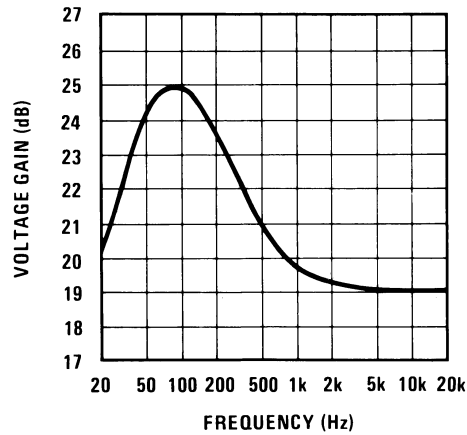

AM Radio Power Amplifier

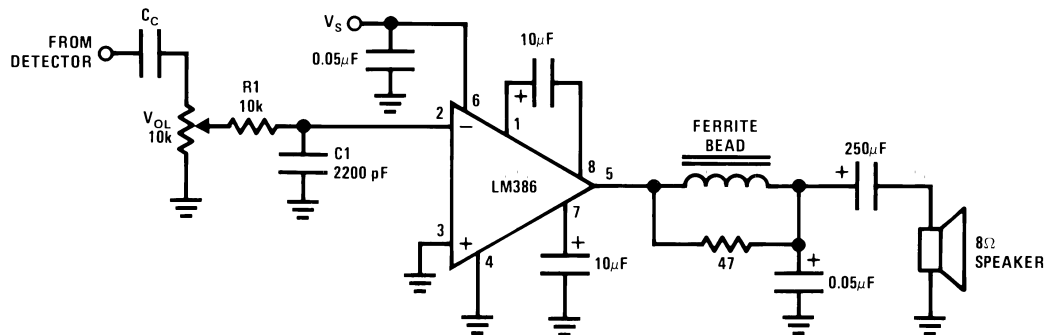

Note 4: Twist Supply lead and supply ground very tightly.

Note 5: Twist speaker lead and ground very tightly.

Note 6: Ferrite bead in Ferroxcube K5-001-001/3B with 3 turns of wire.

Note 7: R1C1 band limits input signals.

Note 8: All components must be spaced very closely to IC.

Physical Dimensions inches (millimeters) unless otherwise noted (Continued)

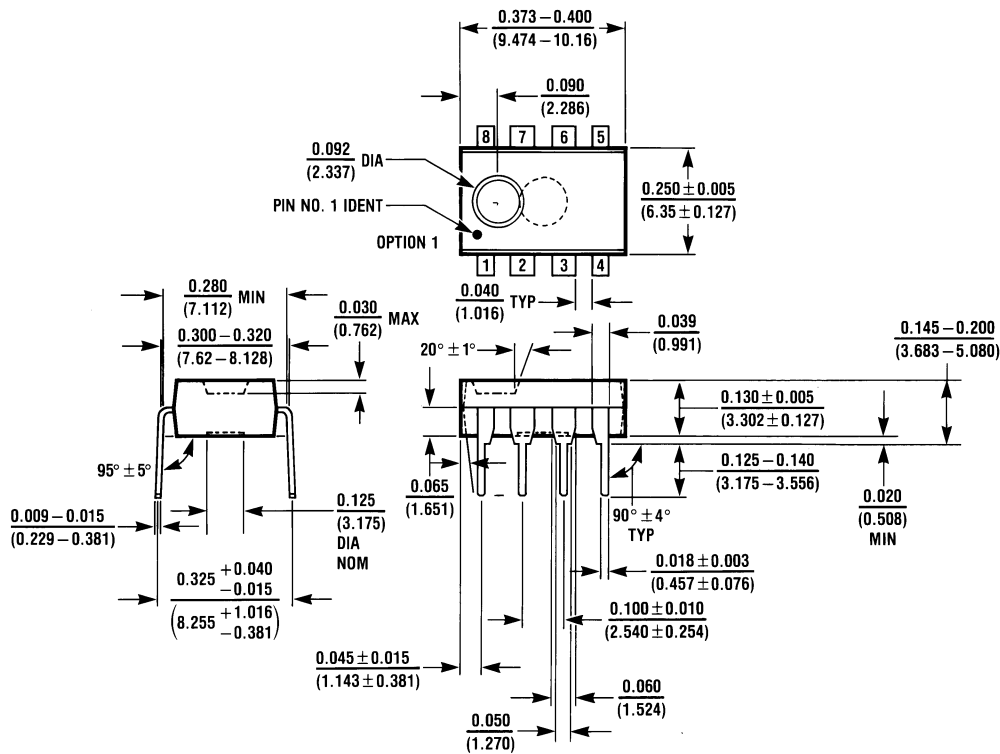

Dual-In-Line Package

LM386N-1

LM386-1

Physical Dimensions inches (millimeters) unless otherwise noted

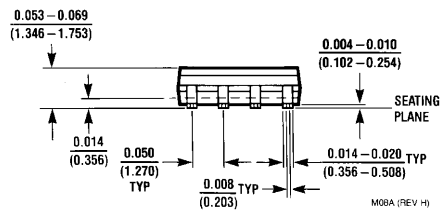
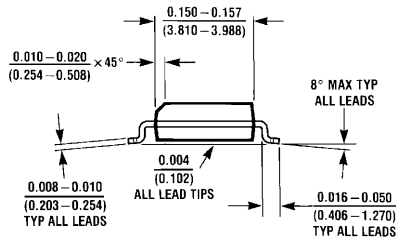
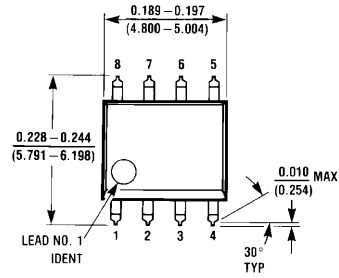

SO Package

LM386M-1