

Power Amplifiers

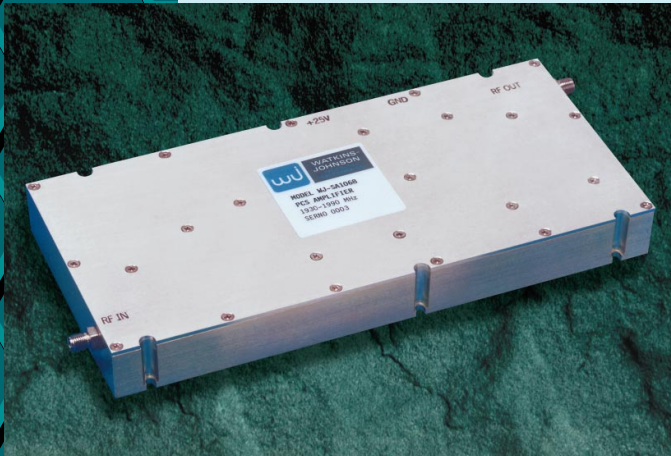

SA1076 TDMA 25-Watt 1.93 GHz to 1.99 GHz Linear Power Amplifier Module

- 25 Watts TDMA IS-136
- +45 dBm P1dB
- 45 dB Gain
- -30°C to +85°C

Watkins-Johnson's SA1076 Power Amplifier provides exceptional linearity and low vector error for TDMA digital modulation applications. Utilizing WJ's GaAs amplifiers driving bipolar transistors in the class AB output stage, the SA1076 achieves a high third-order intercept point combined with superior efficiency when compared to an equivalent power class A amplifier. Special non-linear design techniques are utilized to minimize unwanted adjacent channel power. To aid top level system diagnostics and reliability, the unit includes alarms to identify if an active part fails or if a poor load is presented to the RF output. In the event that a fault is detected or to simply save DC power, a digitaly controlled shutdown is provided. An integral logarithmic power detector measures the output power of the amplifier over a 16 dB dynamic range.

OUTLINE DRAWING

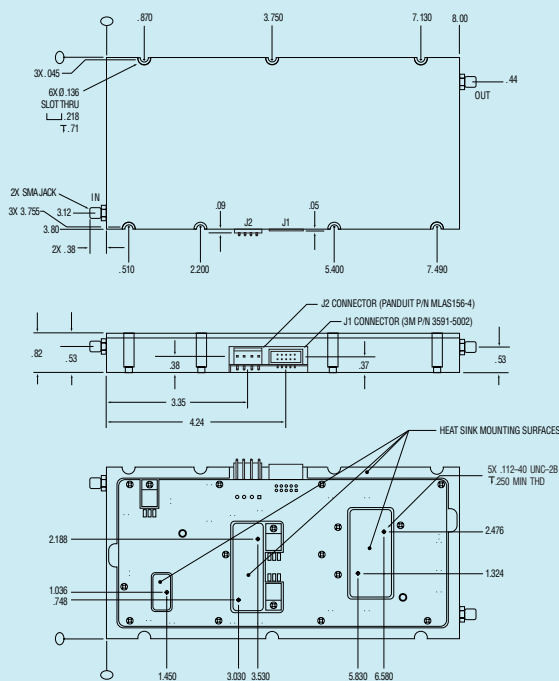

The Wireless Edge™



Power Amplifiers

SA1076 TDMA 25-Watt 1.93 GHz to 1.99 GHz Linear Power Amplifier Module

| Specifications (Preliminary) | | |
|--|---|--|
| Parameters (Baseplate Temperature: -30°C to +85°C) | Typical Level | Specified Limits |
| Frequency | | 1.930-1.990 GHz |
| P _{out} at 1 dB Gain Compression | +45 dBm | |
| Gain (small signal at 25°C) | | 45 ± 1.0 dB |
| Gain Variation over Temp (-30°C to +85°C) | | ±1.5 dB |
| NADC IS-136 Specifications: P _{out} = 25 watts ACP (30 KHz offset) ACP (60 KHz offset) ACP (90 KHz offset) | -30 dBc max -50 dBc max -16 dBm max | -26 dBc max -45 dBc max -13 dBm max |
| Harmonic Output (with a +44.8 dBm TDMA output at the fundamental) a) 2nd Harmonic b) 3rd Harmonic | -5 dBm -30 dBm | |
| Third-Order 2-Tone Output Intermodulation Product Rejection (Measured with +37 dBm per tone, T = +25°C) | -35 dB max | -30 dB max |
| Noise Figure | 5.0 dB | 6.5 dB |
| Input and Output Impedence | | 50 ohm |
| Return Loss (1.930-1.990 GHz) Input and Output | -20 dB | -15 dB |
| Load Mismatch Sustainable without Damage | | 3.0:1 |
| Output Power Monitor a) P _{out} = +44 dBm CW b) P _{out} = +36 dBm CW c) P _{out} = +28 dBm CW | 4.5 V 2.5 V 0.5 V | 5.0 V max, 4.0 V min 3.0 V max, 2.0 V min 1.0 V max, 0.0 V min |
| Supply Voltages | +24 V | 23.5 -26.5 V |
| Maximum Supply without Damage, +24 volt Supply | | +28 VDC |
| Maximum DC Current (P _{out} ≤44 dBm TDMA), +24 volt Supply | 6.0 amps | 7.0 amps |
| DC Power Dissipation (P _{out} ≤44 dBm TDMA), +24 volt Supply | 145 watts | 168 watts |
| RF Connectors | SMA Female | |
| Stability (No spurious outputs above -50 dBc) | Unconditionally stable for all loads | |
| Size (Heat sink not included) | 0.82" (H), 3.80" (W), 8.00" (L) | |
| Weight (Heat sink not included) | 625 grams (22 oz.) | |

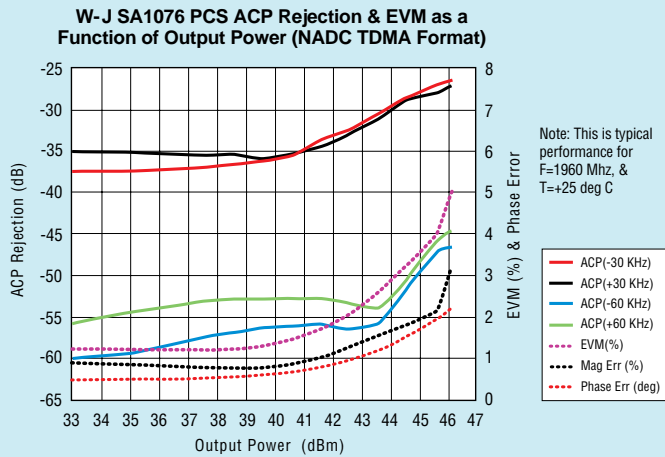

The Wireless Edge™