



WM2617

Dual 10-Bit Serial DAC with Power Down

Production Data, Rev 1.1, October 2000

FEATURES

- Two 10-bit DACs
- Single supply from 2.7V to 5.5V supply operation
- DNL ± 0.1 LSB, INL ± 0.5 LSB
- Low power consumption
 - 3mW typical in slow mode
 - 8mW typical in fast mode
- TMS320, (Q)SPI™, and Microwire™ compatible serial interface
- Programmable settling time 4 μ s or 12 μ s typical

APPLICATIONS

- Battery powered test instruments
- Digital offset and gain adjustment
- Battery operated/remote industrial controls
- Machine and motion control devices
- Wireless telephone and communication systems
- Speech synthesis
- Arbitrary waveform generation

ORDERING INFORMATION

| DEVICE | TEMP. RANGE | PACKAGE |
|----------|--------------|------------|
| WM2617CD | 0° to 70°C | 8-pin SOIC |
| WM2617ID | -40° to 85°C | 8-pin SOIC |

DESCRIPTION

The WM2617 is a dual 10-bit voltage output, resistor string, digital-to-analogue converter. A power-on-reset function ensures repeatable start-up conditions.

The device has been designed to interface efficiently to industry standard microprocessors and DSPs, including the TMS320 family. The WM2617 is programmed with a 16-bit serial word. The WM2617 has a simple-to-use single 2.7V to 5.5V supply. The digital inputs feature Schmitt triggers for high noise immunity.

The number of clocks from the falling edge of NCS are counted automatically. The device is then updated and disabled from accepting further data inputs.

Excellent performance is delivered with a typical DNL of ± 0.1 LSBs. The settling time of the DAC is programmable to allow the designer to optimise speed versus power dissipation.

The device is available in an 8-pin SOIC package ideal for space-critical applications. Commercial temperature (0° to 70°C) and industrial temperature (-40° to 85°C) variants are supported.

BLOCK DIAGRAM

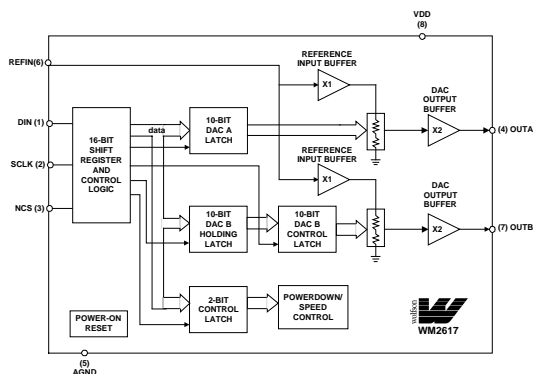

TYPICAL PERFORMANCE

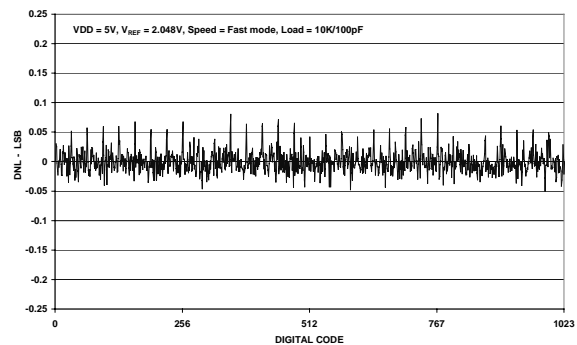

PIN CONFIGURATION

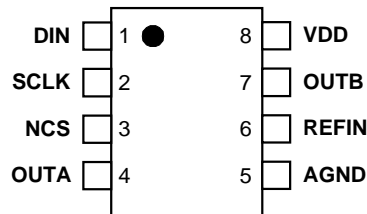

PIN DESCRIPTION

| PIN NO | NAME | TYPE | DESCRIPTION |
|--------|-------|-----------------|--------------------------|
| 1 | DIN | Digital input | Serial data input. |
| 2 | SCLK | Digital input | Serial clock input. |
| 3 | NCS | Digital input | Chip select, active low. |
| 4 | OUTB | Analogue output | DAC B analogue output. |
| 5 | AGND | Supply | Analogue ground. |
| 6 | REFIN | Analogue input | Reference voltage input. |
| 7 | OUTA | Analogue output | DAC A analogue output. |
| 8 | VDD | Supply | Positive power supply. |

ABSOLUTE MAXIMUM RATINGS

Absolute Maximum Ratings are stress ratings only. Permanent damage to the device may be caused by continuously operating at or beyond these limits. Device functional operating limits and guaranteed performance specifications are given under Electrical Characteristics at the test conditions specified



ESD Sensitive Device. This device is manufactured on a CMOS process. It is therefore generically susceptible to damage from excessive static voltages. Proper ESD precautions must be taken during handling and storage of this device.

| CONDITION | | MIN | MAX |
|---|----------|-------|------------|
| Supply voltage, VDD to AGND | | | 7V |
| Digital input voltage | | -0.3V | VDD + 0.3V |
| Reference input voltage | | -0.3V | VDD + 0.3V |
| Operating temperature range, T _A | WM2617CD | 0°C | 70°C |
| | WM2617ID | -40°C | 85°C |
| Storage temperature | | -65°C | 150°C |
| Lead temperature 1.6mm (1/16 inch) soldering for 10 seconds | | | 260°C |

RECOMMENDED OPERATING CONDITIONS

| PARAMETER | SYMBOL | TEST CONDITIONS | MIN | TYP | MAX | UNIT |
|----------------------------------|-------------------|-----------------|-----|-----|-----------|------|
| Supply voltage | VDD | | 2.7 | | 5.5 | V |
| High-level digital input voltage | V _{IH} | VDD = 5V | 2 | | | V |
| Low-level digital input voltage | V _{IL} | VDD = 5V | | | 0.8 | V |
| Reference voltage to REFIN | V _{REF} | | | | VDD - 1.5 | V |
| Load resistance | R _L | | 2 | | | kΩ |
| Load capacitance | C _L | | | | 100 | |
| Serial Clock Rate | f _{SCLK} | | | | 20 | |
| Operating free-air temperature | T _A | WM2637CD | 0 | | 70 | °C |
| | | WM2637ID | -40 | | 85 | °C |

Note: Reference voltages greater than VDD/2 will cause saturation for large DAC codes.

ELECTRICAL CHARACTERISTICS

Test Conditions:

$R_L = 10k\Omega$, $C_L = 100pF$. $V_{DD} = 5V \pm 10\%$, $V_{REF} = 2.048V$ and $V_{DD} = 3V \pm 10\%$, $V_{REF} = 1.024V$ over recommended operating free-air temperature range (unless noted otherwise)

| PARAMETER | SYMBOL | TEST CONDITIONS | MIN | TYP | MAX | UNIT |
|---|-------------|--|------------|------------|----------------|--------------------------|
| Static DAC Specifications | | | | | | |
| Resolution | | | 10 | | | bits |
| Integral non-linearity | INL | See Note 1 | | | ± 1 | LSB |
| Differential non-linearity | DNL | See Note 2 | | ± 0.1 | ± 0.5 | LSB |
| Zero code error | ZCE | See Note 3 | | 3 | ± 12 | mV |
| Gain error | GE | See Note 4 | | 0.1 | ± 0.6 | % FSR |
| D.c. power supply rejection ratio | DC PSRR | See Note 5 | | 0.5 | | mV/V |
| Zero code error temperature coefficient | | See Note 6 | | 10 | | ppm/ $^{\circ}C$ |
| Gain error temperature coefficient | | See Note 6 | | 10 | | ppm/ $^{\circ}C$ |
| DAC Output Specifications | | | | | | |
| Output voltage range | | | 0 | | $V_{DD} - 0.1$ | V |
| Output load regulation | | 2k Ω to 10k Ω load See Note 7 | | 0.1 | 0.3 | % |
| Power Supplies | | | | | | |
| Active supply current | I_{DD} | No load, $V_{IH} = V_{DD}$, $V_{IL} = 0V$ $V_{DD} = 5.5V$, $V_{REF} = 2.048V$ Slow $V_{DD} = 5.5V$, $V_{REF} = 2.048V$ Fast See Note 8 | | 0.6 1.6 | 1.0 2.5 | mA mA |
| Power down supply current | | No load, all digital inputs 0V or VDD | | 0.01 | | μA |
| Dynamic DAC Specifications | | | | | | |
| Slew rate | | DAC code 32 to 1023, 10%-90% Slow Fast See Note 9 | 0.3 2.4 | 0.5 3.0 | | V/ μs V/ μs |
| Settling time | | DAC code 32 to 1023 Slow Fast See Note 10 | | 12 4 | | μs μs |
| Glitch energy | | Code 511 to 512 | | 10 | | nV-s |
| Reference | | | | | | |
| Reference input resistance | R_{REFIN} | | | 10 | | M Ω |
| Reference input capacitance | C_{REFIN} | | | 5 | | pF |
| Reference feedthrough | | $V_{REF} = 1V_{PP}$ at 1kHz + 1.024V dc, DAC code 0 | | -60 | | dB |
| Reference input bandwidth | | $V_{REF} = 0.2V_{PP} + 1.024V$ dc DAC code 512 Slow Fast | | 0.5 1.0 | | MHz MHz |
| Digital Inputs | | | | | | |
| High level input current | I_{IH} | Input voltage = VDD | | | 1 | μA |
| Low level input current | I_{IL} | Input voltage = 0V | | | -1 | μA |
| Input capacitance | C_I | | | 8 | | pF |

Notes:

1. **Integral non-linearity (INL)** is the maximum deviation of the output from the line between zero and full scale (excluding the effects of zero code and full scale errors).
2. **Differential non-linearity (DNL)** is the difference between the measured and ideal 1LSB amplitude change of any adjacent two codes. A guarantee of monotonicity means the output voltage changes in the same direction (or remains constant) as a change in digital input code.
3. **Zero code error** is the voltage output when the DAC input code is zero.
4. **Gain error** is the deviation from the ideal full scale output excluding the effects of zero code error.
5. **Power supply rejection ratio** is measured by varying VDD from 4.5V to 5.5V and measuring the proportion of this signal imposed on the zero code error and the gain error.
6. **Zero code error** and **Gain error** temperature coefficients are normalised to full scale voltage.
7. **Output load regulation** is the difference between the output voltage at full scale with a 10kΩ load and 2kΩ load. It is expressed as a percentage of the full scale output voltage with a 10kΩ load.
8. **I_{DD}** is measured while continuously writing code 2048 to the DAC. For $V_{IH} < V_{DD} - 0.7V$ and $V_{IL} > 0.7V$ supply current will increase.
9. **Slew rate** results are for the lower value of the rising and falling edge slew rates.
10. **Settling time** is the time taken for the signal to settle to within 0.5LSB of the final measured value for both rising and falling edges. Limits are ensured by design and characterisation, but are not production tested.

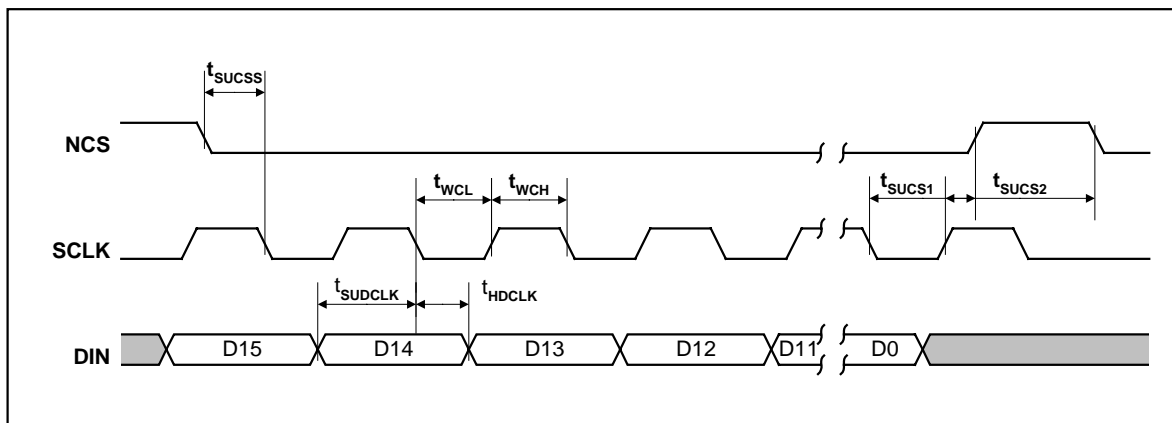
SERIAL INTERFACE**Figure 1 Timing Diagram****Test Conditions:**

$R_L = 10k\Omega$, $C_L = 100pF$. $V_{DD} = 5V \pm 10\%$, $V_{REF} = 2.048V$ and $V_{DD} = 3V \pm 10\%$, $V_{REF} = 1.024V$ over recommended operating free-air temperature range (unless noted otherwise)

| SYMBOL | TEST CONDITIONS | MIN | TYP | MAX | UNIT |
|--------------|---|-----|-----|-----|------|
| t_{SUCSS} | Setup time NCS low before SCLK low | 5 | | | ns |
| t_{SUCS1} | Setup time, falling edge of SCLK to rising edge of NCS, external end of write | 10 | | | ns |
| t_{SUCS2} | Setup time, rising edge of SCLK to falling edge of NCS, start of next write cycle | 5 | | | ns |
| t_{WCH} | Pulse duration, SCLK high | 25 | | | ns |
| t_{WCL} | Pulse duration, SCLK low | 25 | | | ns |
| t_{SUDCLK} | Setup time, data ready before SCLK falling edge | 5 | | | ns |
| t_{HDCLK} | Hold time, data held valid after SCLK falling edge | 5 | | | ns |

TYPICAL PERFORMANCE GRAPHS

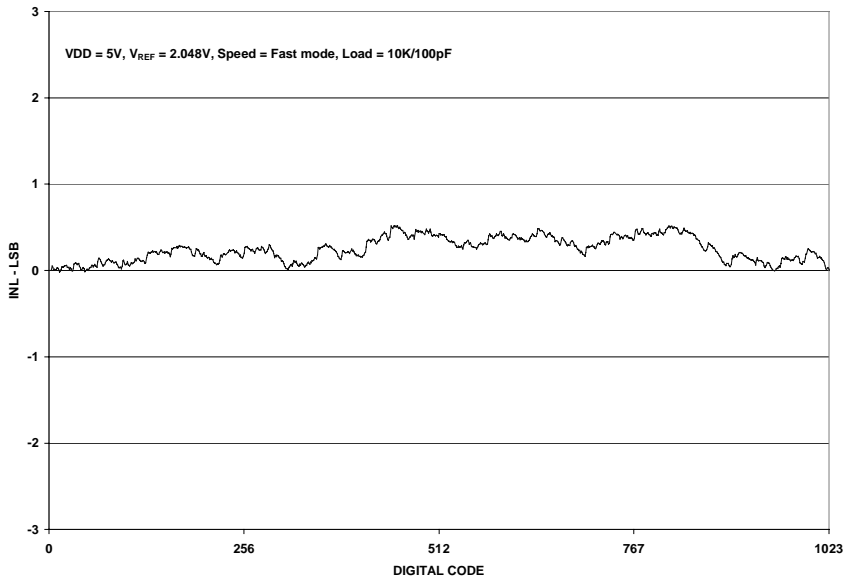

Figure 2 Integral Non-Linearity

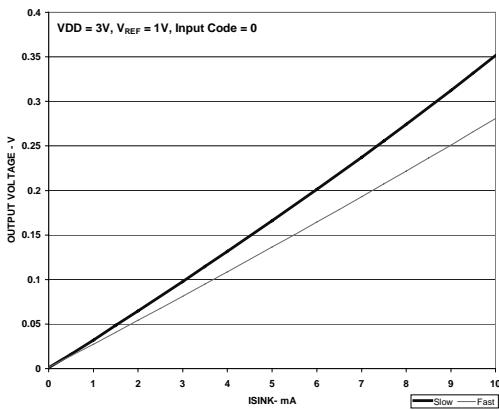

Figure 3 Sink Current VDD = 3V

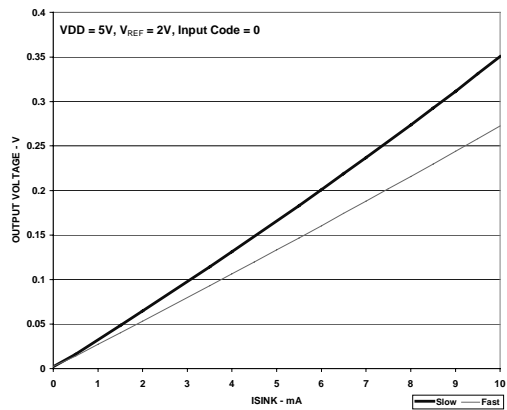

Figure 4 Sink Current VDD = 5V

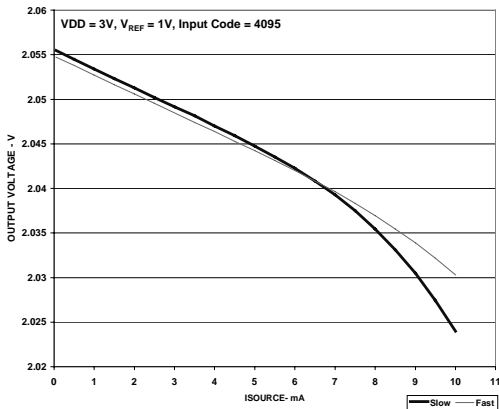

Figure 5 Source Current VDD = 3V

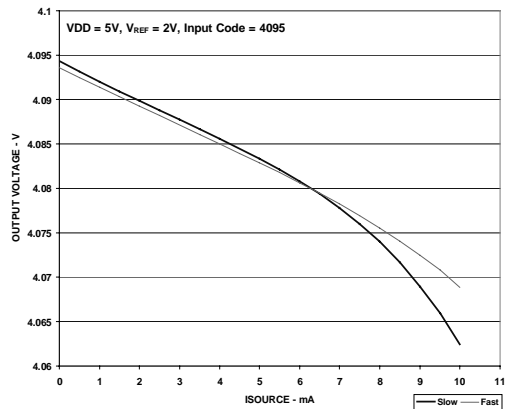

Figure 6 Source Current VDD = 5V

DEVICE DESCRIPTION

GENERAL FUNCTION

The device uses a resistor string network buffered with an op amp to convert 10-bit digital data to analogue voltage levels (see Block Diagram). The output voltage is determined by the reference input voltage and the input code according to the following relationship:

$$\text{Output voltage} = 2(V_{\text{REF}}) \frac{\text{code}}{1024}$$

| INPUT | | | OUTPUT |
|-------|------|------|---|
| 11 | 1111 | 1111 | $2(V_{\text{REF}}) \frac{1023}{1024}$ |
| | : | | : |
| 10 | 0000 | 0001 | $2(V_{\text{REF}}) \frac{513}{1024}$ |
| 10 | 0000 | 0000 | $2(V_{\text{REF}}) \frac{512}{1024} = V_{\text{REF}}$ |
| 01 | 1111 | 1111 | $2(V_{\text{REF}}) \frac{511}{1024}$ |
| | : | | : |
| 00 | 0000 | 0001 | $2(V_{\text{REF}}) \frac{1}{1024}$ |
| 00 | 0000 | 0000 | 0V |

Table 1 Binary Code Table (0V to 2V_{REF} Output), Gain = 2

POWER ON RESET

An internal power-on-reset circuit resets the DAC registers to all 0s on power-up.

BUFFER AMPLIFIER

The output buffer has a near rail-to-rail output with short circuit protection and can reliably drive a 2kΩ load with a 100pF load capacitance.

EXTERNAL REFERENCE

The reference voltage input is buffered which makes the DAC input resistance independent of code. The REFIN input resistance is 10MΩ and the REFIN input capacitance is typically 5pF. The reference voltage determines the DAC full-scale output.

SERIAL INTERFACE

When chip select (NCS) is low, the input data is read into a 16-bit shift register with the input data clocked in most significant bit first. The falling edge of the SCLK input shifts the data into the input register. After 16 bits have been transferred, the next rising edge on SCLK or NCS then transfers the data to the DAC latch. When NCS is high, input data cannot be clocked into the input register (see Table 2).

SERIAL CLOCK AND UPDATE RATE

Figure 1 shows the device timing. The maximum serial rate is:

$$f_{\text{SCLKmax}} = \frac{1}{t_{\text{WCHmin}} + t_{\text{WCLmin}}} = 20\text{MHz}$$

The digital update rate is limited to an 800ns period, or 1.25MHz frequency. However, the DAC settling time to 10 bits limits the update rate for large input step transitions.

SOFTWARE CONFIGURATION OPTIONS

The 16 bits of data can be transferred with the sequence shown in Table 2. D11-D2 contains the 10-bit data word. D15-D12 hold the programmable options which are summarized in Table 3.

| D15 | D14 | D13 | D12 | D11 | D10 | D9 | D8 | D7 | D6 | D5 | D4 | D3 | D2 | D1 | D0 |
|--------------|-----|-----|-----|-------------------------|-----|----|----|----|----|----|----|----|----|----|----|
| Program Bits | | | | New DAC value (10 bits) | | | | | | | | | | x | x |

Table 2 Register Map

| PROGRAM BITS | | | | DEVICE FUNCTION |
|--------------|-----|-----|-----|--|
| D15 | D14 | D13 | D12 | |
| 1 | X | X | X | Write to latch A with serial interface register data and latch B updated with buffer latch data. |
| 0 | X | X | 0 | Write to latch B and double buffer latch. |
| 0 | X | X | 1 | Write to double buffer latch only. |
| X | 0 | X | X | 12 μ s settling time. |
| X | 1 | X | X | 4 μ s settling time. |
| X | X | 0 | X | Powered-up operation. |
| X | X | 1 | X | Power down mode. |

Table 3 Program Bits D15 to D12 Function

PROGRAMMABLE SETTILING TIME

Settling time is a software selectable 12 μ s or 4 μ s, typical to within ± 0.5 LSB of final value. This is controlled by the value of D14. A ONE defines a settling time of 4 μ s, a ZERO defines a settling time of 12 μ s.

PROGRAMMABLE POWER DOWN

The power down function is controlled by D13. A ZERO configures the device as active, or fully powered up, a ONE configures the device into power down mode. When the power down function is released the device reverts back to the DAC code set prior to power down.

FUNCTION OF THE LATCH CONTROL BITS (D15 AND D12)

PURPOSE AND USE OF THE DOUBLE BUFFER

Normally only one DAC output can change after a write. The double buffer allows both DAC outputs to change after a single write. This is achieved by the two following steps.

1. A double buffer only write is executed to store the new DAC B data without changing the DAC A and B outputs.
2. Following the previous step, a write to latch A is executed. This writes the serial interface register (SIR) data to latch A and also writes the double buffer contents to latch B. Thus both DACs receive their new data at the same time and so both DAC outputs begin to change at the same time.

Unless a double buffer only write is issued, the latch B and double buffer contents are identical. Thus, following a write to latch A or B with another write to latch A does not change the latch B contents.

Three data transfer options are possible. All transfers occur immediately after NCS goes high (or on the sixteenth positive SCLK edge, whichever is earlier) and are described in the following sections.

LATCH A WRITE, LATCH B UPDATE (D15 = HIGH, D12 = X)

The serial interface register (SIR) data are written to latch A and the double buffer latch contents are written to latch B. The double buffer contents are unaffected. This program bit condition allows simultaneous output updates of both DACs.

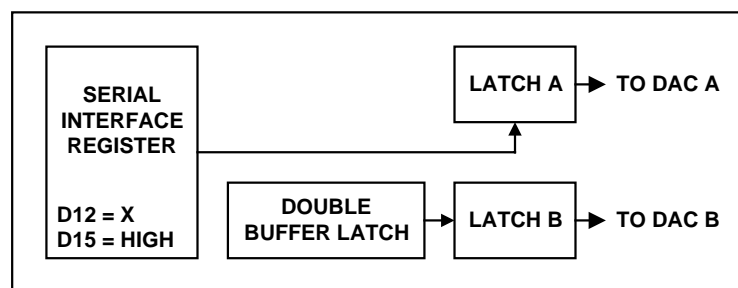

Figure 7 Latch A Write, Latch B Update

LATCH B AND DOUBLE BUFFER WRITE (D15 = LOW, D12 = LOW)

The SIR data are written to both latch B and the double buffer. Latch A is unaffected.

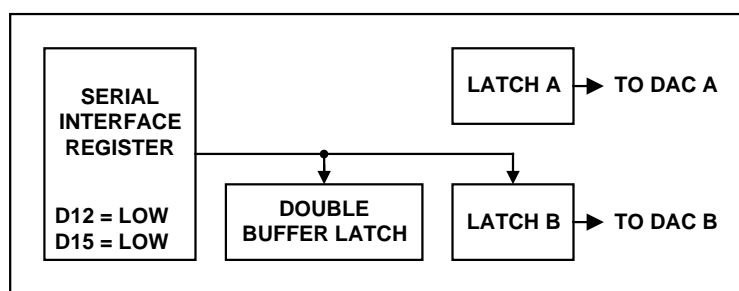

Figure 8 Latch B and Double Buffer Write

DOUBLE BUFFER ONLY WRITE (D15 = LOW, D12 = HIGH)

The SIR data are written to the double buffer only. Latch A and B contents are unaffected.

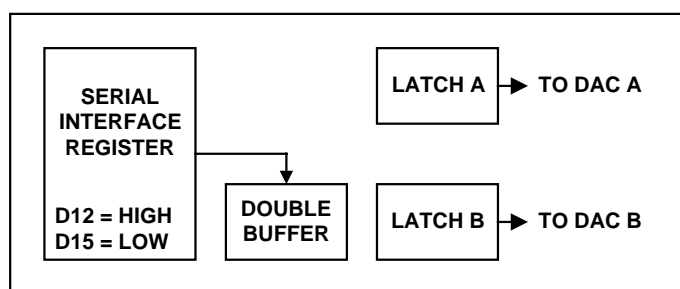

Figure 9 Double Buffer Only Write

OPERATIONAL EXAMPLES

1. changing the latch A data from zero to full code

Assuming that latch A starts at zero code (e.g., after power up), the latch can be filled with 1s by writing (bit D15 on the left, D0 on the right)

1X0X 1111 1111 11xx

to the serial interface. Bit D14 can be zero to select slow mode or one to select fast mode. The other X can be zero or one (don't care).

The latch B contents and DAC B output are not changed by this write unless the double buffer contents are different from the latch B contents. This can only be true if the last write was a double buffer-only write.

2. changing the latch B data from zero to full code

Assuming that latch B starts at zero code (e.g., after power up), the latch can be filled with 1s by writing (bit D15 on the left, D0 on the right).

0X00 1111 1111 11xx

to the serial interface. Bit D14 can be zero to select slow mode or one to select fast mode. The data (bits D0 to D11) are written to both the double buffer and latch B.

The latch A contents and the DAC A output are not changed by this write.

3. double buffered change of both DAC outputs

Assuming that DACs A and B start at zero code (e.g., after power up), if DAC A is to be driven to mid-scale and DAC B to full-scale, and if the outputs are to begin rising at the same time, this can be achieved as follows:

First,

0d01 1111 1111 11xx

is written (bit D15 on the left, D0 on the right) to the serial interface. This loads the full-scale code into the double buffer but does not change the latch B contents and the DAC B output voltage. The latch A contents and the DAC A output are also unaffected by this write operation.

Changing from fast to slow to fast mode changes the supply current which can glitch the outputs, and so D14 (designated by d in the above data word) should be set to maintain the speed mode set by the previous write.

Next,

1d0X 1000 0000 00xx

is written (bit D15 on the left, D0 on the right) to the serial interface. Bit D14 can be zero to select slow mode or one to select fast mode. The X in bit D12 can be zero or one (don't care). This writes the mid-scale code (100000000000) to latch A and also copies the full-scale code from the double buffer to latch B. Both DAC outputs thus begin to rise after the second write.

PACKAGE DIMENSIONS

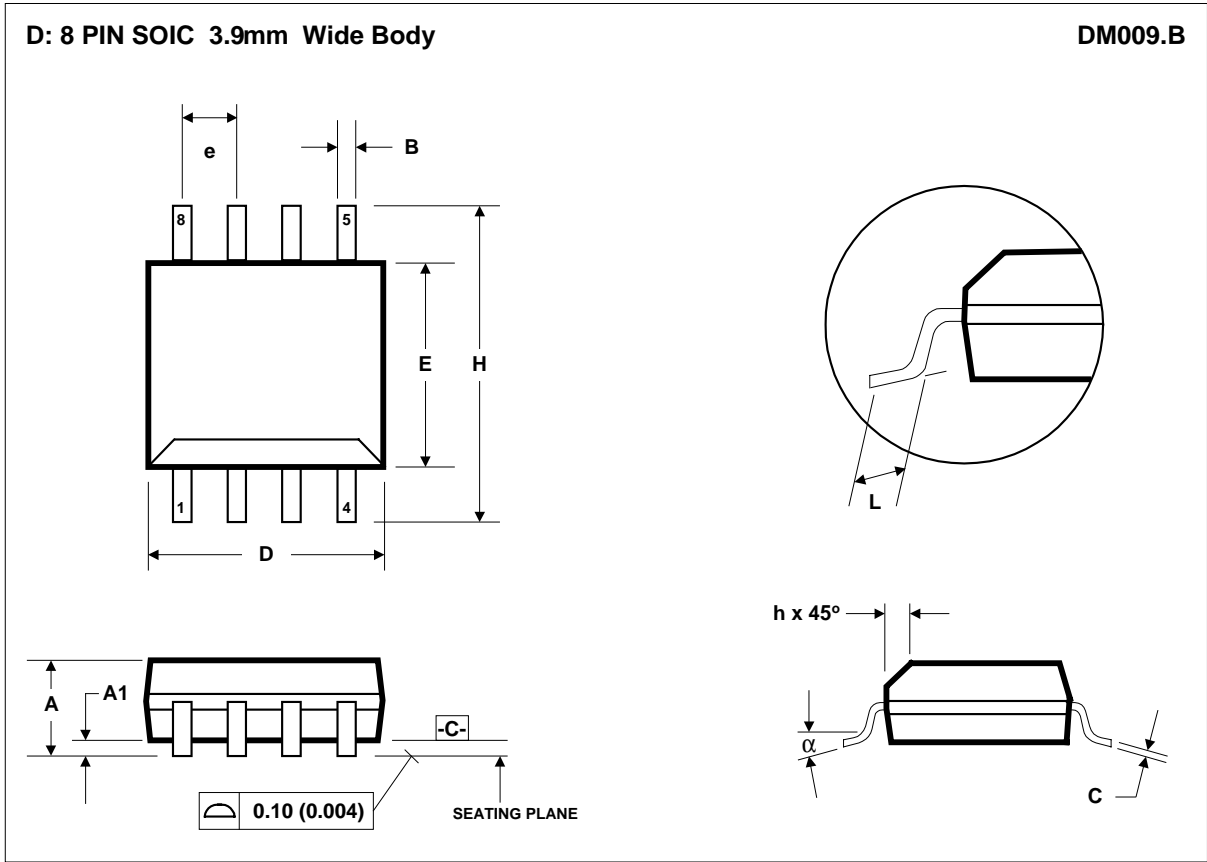

| Symbols | Dimensions (mm) | | Dimensions (Inches) | |
|----------------------|------------------|------|---------------------|--------|
| | MIN | MAX | MIN | MAX |
| A | 1.35 | 1.75 | 0.0532 | 0.0688 |
| A₁ | 0.10 | 0.25 | 0.0040 | 0.0098 |
| B | 0.33 | 0.51 | 0.0130 | 0.0200 |
| C | 0.19 | 0.25 | 0.0075 | 0.0098 |
| D | 4.80 | 5.00 | 0.1890 | 0.1968 |
| e | 1.27 BSC | | 0.050 BSC | |
| E | 3.80 | 4.00 | 0.1497 | 0.1574 |
| h | 0.25 | 0.50 | 0.0099 | 0.0196 |
| H | 5.80 | 6.20 | 0.2284 | 0.2440 |
| L | 0.40 | 1.27 | 0.0160 | 0.0500 |
| α | 0° | 8° | 0° | 8° |
| REF: | JEDEC.95, MS-012 | | | |

NOTES:
 A. ALL LINEAR DIMENSIONS ARE IN MILLIMETERS (INCHES).
 B. THIS DRAWING IS SUBJECT TO CHANGE WITHOUT NOTICE.
 C. BODY DIMENSIONS DO NOT INCLUDE MOLD FLASH OR PROTRUSION, NOT TO EXCEED 0.25MM (0.010IN).
 D. MEETS JEDEC.95 MS-012, VARIATION = AA. REFER TO THIS SPECIFICATION FOR FURTHER DETAILS.