

## PLCC DAA for Shared-Line Applications

### Description

Xecom's XE014JS is a complete DAA integrated into a compact PLCC package. The XE014JS incorporates features which permit equipment to share a host telephone line. The PLCC package reduces the DAA space requirements and permits automated, high-volume assembly.

The XE014JS is targeted for remote monitoring equipment which shares a host telephone line such as set top boxes and automated utility meters. The XE014JS includes a pair of circuits which prevent the equipment from interfering with host calls. The Connect Detect circuit monitors line activity and indicates when the host telephone line is in use. By monitoring this signal the equipment avoids interruption of a host call in progress. The handset interrupt circuit monitors the host telephone line for interruptions while the equipment is on-line. this permits the equipment to drop the call in progress if the host picks-up the telephone line.

Like all Xecom DAA's the XE014JS is a complete telephone line interface. It includes the telephone line transformer, line current holding circuit, hookswitch and ring indicator. The XE014JS replaces the dozens of components found in a discrete design with a complete, tested solution.

### Features

- \* Package: 68-Pin PLCC (only 18 pins used) 0.952 inches by 0.952 inches by 0.170 inches high
- \* Integrated Telephone Line Transformer
- \* Integrated Ring Detection with active high and active low output signals
- \* Operates on a single Power Supply of +5 Volts;
- \* Solid-State Hookswitch Control with active high and active low inputs;
- \* Integrated Connect Detection monitor;
- \* Integrated Handset Interrupt circuit;
- \* FCC Part 68 Compliant;
- \* Extended Temperature Range available;

**Figure 1: XE014JS BLOCK DIAGRAM**

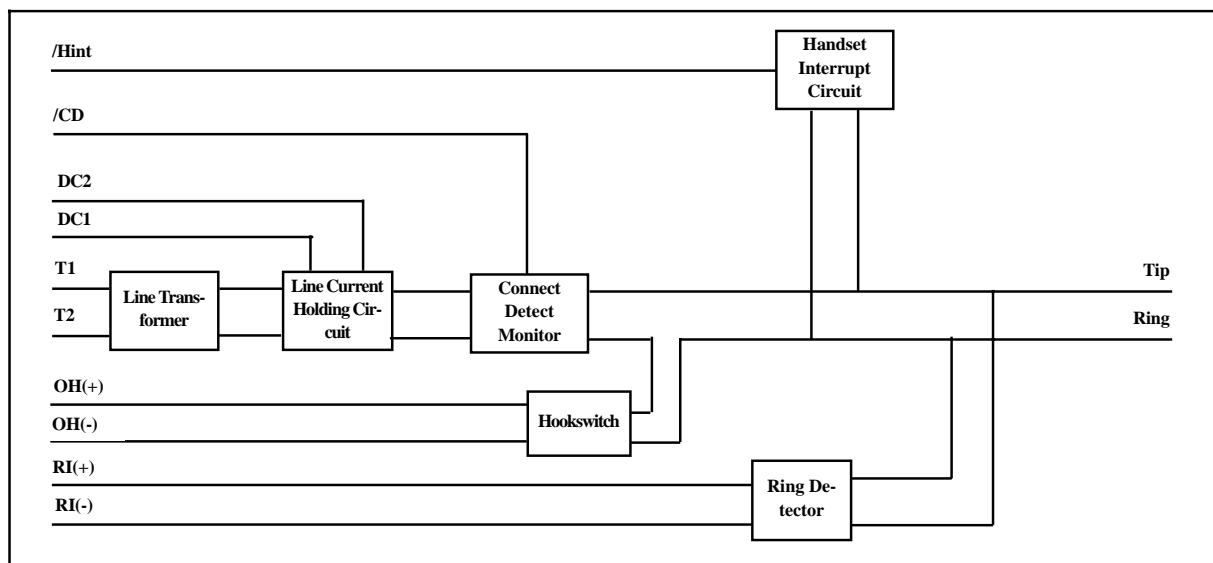

**Figure 2: XE014JS Pin Configuration**

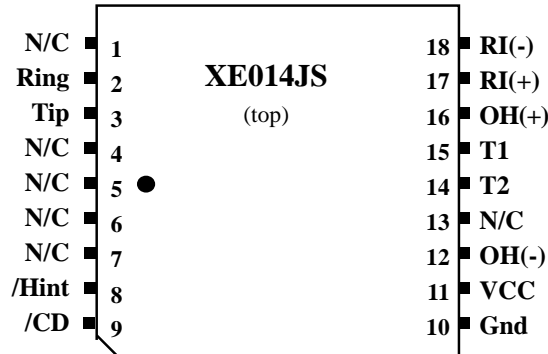

### Pin Descriptions

PIN	NAME	DESCRIPTION
1	N/C	No Connection
2	Ring	Ring is one wire of the two-wire telephone line connection (RJ11 Pin 4). FCC Part 68 Rules require a 1500 volt isolation barrier between the telephone line and all other circuits. This isolation must be preserved throughout the system. Xecom recommends 0.100 inch spacing between traces connected to Ring and all other conductors to preserve this isolation.
3	Tip	Tip is one wire of the two-wire telephone line connection (RJ11 Pin 3). The telephone company places a DC "Battery" voltage across Tip and Ring on all public switched telephone lines. The XE014JS accepts this line battery voltage without regard to its polarity.
4-7	N/C	No Connection
8	/Hint	Handset Interrupt provides an active low output to indicate when another piece of equipment goes off-hook on the shared telephone line. When the XE014JS detects a drop of at least one volt in the DC line voltage, /Hint goes low for two to six seconds to notify the host equipment that the is required by other equipment. The host equipment is responsible for deactivating the OH line to return the XE014JS to the on-hook state.
9	/CD	Connect Detect is an active low output which indicates that the local telephone line is available for use. /CD remains active as long as the DC line voltage remains above 36 volts.
10	GND	Ground connection to the XE014JS. This signal provides the reference for the OH output and RI input. This pin should be connected to the systems digital ground.
11	VCC	+5 Volt power source for the XE014JS. VCC powers the RI and OH control lines.
12	OH(-)	Modem switch-hook control: OH(-), an active low input, for controls the switch hook in the XE014JS. When the host activates pin 12, the switch-hook closes and the XE014JS seizes the local telephone line. Pin 16 provides an active high switch-hook control. OH(-) should remain open when using OH(+).  The host can pulse OH(-) line to perform rotary dialing. The normal pulse rate is ten pulses per second. Closing the switch-hook creates a series of pulses. Dial one pulse for the digit one to ten pulses for the digit zero. The pulses on OH(-) must be asymmetrical, active for thirty-one milliseconds, inactive for sixty-nine milliseconds. An inter-digit delay of at least one hundred milliseconds is required.

---

## Pin Descriptions

PIN	NAME	DESCRIPTION
13	N/C	No Connection
14	T2	T2 in conjunction with T1 provides the differential input/output for the analog signal. T2 connects directly to the secondary side of the miniature line transformer embedded into the XE014JS. To match the impedance of the DAA to the 600 ohm telephone line, a 340 ohm resistor must be connected in series with T1 or T2.
15	T1	T1 in conjunction with T2 provides the differential input/output for the analog signal. T1 connects directly to the secondary side of the miniature line transformer embedded into the XE014JS. To match the impedance of the DAA to the 600 ohm telephone line, a 340 ohm resistor must be connected in series with T1 or T2.
16	OH(+)	Switch-hook control to the modem. OH(+) provides an active high input for controlling the switch hook. When pin 16 is active, the switch-hook closes and the XE014JS seizes the local telephone line. OH(+) should remain open when using OH(-).  The host can pulse OH(+) line to perform rotary dialing. The normal pulse rate is ten pulses per second. Closing the switch-hook creates these pulses. Dial one pulse for the digit one to ten pulses for the digit zero. The pulses on OH(+) must be asymmetrical, active for thirty-one milliseconds, inactive for sixty-nine milliseconds. An inter-digit delay of at least one hundred milliseconds is required.
17	RI(+)	Ring Indicate output from the modem. RI(+) is an active high output. RI(+) provides a square wave representation of the Ring signal present across Tip and Ring. This permits intelligent monitoring of the incoming ring. The XE014JS recognizes ring voltages of thirty-eight to one hundred fifty volts RMS in the frequency range of sixteen to sixty-eight Hertz. When using RI(+), a 20K pull-down resistor is required on Pin 17 and Pin 18, RI(-), must be tied to ground.
18	RI(-)	Ring Indicate output from the modem. RI(-) is an active low output. RI(-) provides a square wave representation of the Ring signal present across Tip and Ring. This permits intelligent monitoring of the incoming ring. The XE014JS recognizes ring voltages of thirty-eight to one hundred fifty volts RMS in the frequency range of sixteen to sixty-eight Hertz. When using RI(-), a 20K pull-up resistor is required on Pin 18 and Pin 17, RI(+), must be applied to VCC.

## Electrical Specification (V<sub>cc</sub>=+5v ±10%, T<sub>a</sub>=0 to 70 deg C)

Parameter	Conditions	Min	Typ	Max	Units
Power Supply Current	Off-hook		10		mA
	On-hook		1.0		mA
Transmit Insertion loss	600 Ohm Impedance, 1800 Hz	4.4	5.4	6.4	dB
Receive Insertion loss	600 Ohm Impedance, 1800 Hz	4.4	5.4	6.4	dB
Line Matching Impedance	Input to T1 and T2	320	340	360	ohms
Line Impedance	340 ohm matching impedance resistor	540	600	660	ohms
Total Harmonic Distortion	600 Ohm Impedance, 100 to 4000 Hz	-76	-80		dB
Ring Detect Sensitivity	Min. AC voltage between Tip & Ring Type B ringer	20		150	V <sub>rms</sub>
Ring Frequencies Detected		16		68	Hz
RI Output Voltage	Ring signal present, Active low		0.2	0.5	Volts
	Ring signal present, Active High	2.0		5.0	Volts
Hook-Switch Control Voltage (active high)	ON: (off-hook)		0.2	0.5	Volts
	OFF: (on-hook)	2.0	3.0		Volts
Hook-Switch Control Voltage (active low)	ON: (off-hook)	2.0	3.0		Volts
	OFF: (on-hook)		0.2	0.5	Volts
Hook-Switch Control Current	ON: (off-hook)		5	10	milliamps
	OFF: (on-hook)			5	microamps
Loop Current (current draw from line)	No Connection from DC1 to DC2	20		100	mA
	DC1 shorted to DC2	10		60	
DC On-Hook Impedance	Hookswitch Open	10			MOhms
Connect Detect Threshold	On-Hook		36		Volts DC
Handset Detect Threshold	Off-Hook		D1		Volts DC

## Mechanical Specifications

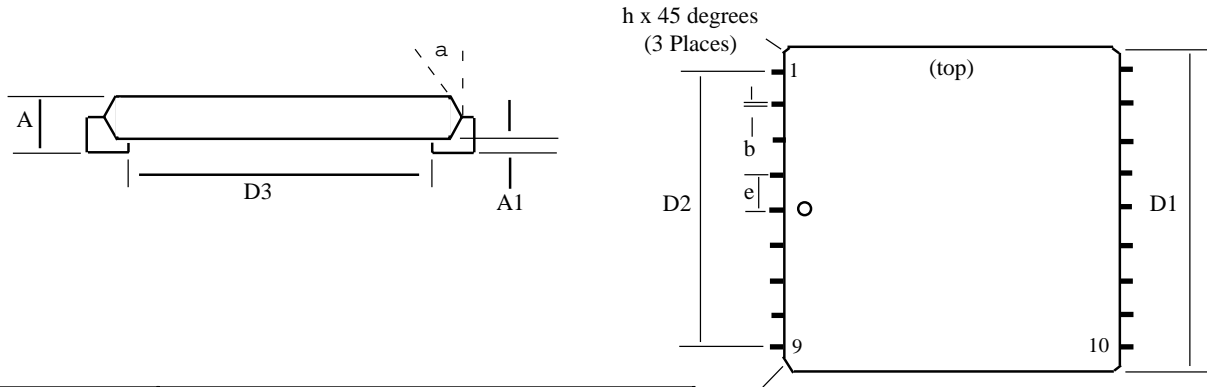

Dim	Inches			Millimeters		
	Min	Ref	Max	Min	Ref	Max
A		0.170			4.32	
A1	0.020			0.51		
b	0.017		0.021	4.32		5.33
D	0.985		0.995	25.0		25.27
D1		0.952			24.18	
D2		0.800			20.32	
D3	0.910		0.930	23.1		23.62
e		0.100			2.54	
h		0.010			0.25	
J		0.045			1.15	
a		45°			45°	
coplanarity			0.004			0.10

## XE014JS ABSOLUTE MAXIMUM RATINGS

Storage Temperature	-25° C to +85° C
Operating Temperature Range *	0° C to +70° C
* The XE014JS can be ordered with an Operating Temperature of -40° C to +85° C at extra cost. Order XE014JS-ITR to specify Industrial Temperature Range (ITR).	

## XE014JS Soldering Instructions

Because of its Hybrid construction, the XE014JS PLCC DAA's are subject to damage if over-exposed to heat during solder reflow operations. Following the soldering instructions below will ensure that the process of soldering the module to the board does not damage the DAA.

Maximum Temperature	220° C
Maximum Time at 220° C	20 Seconds
Maximum Time above Eutectic (180° C)	90 Seconds
Maximum Preheat Dwell Time	180 Seconds

### Maximum Recommended Solder Profile

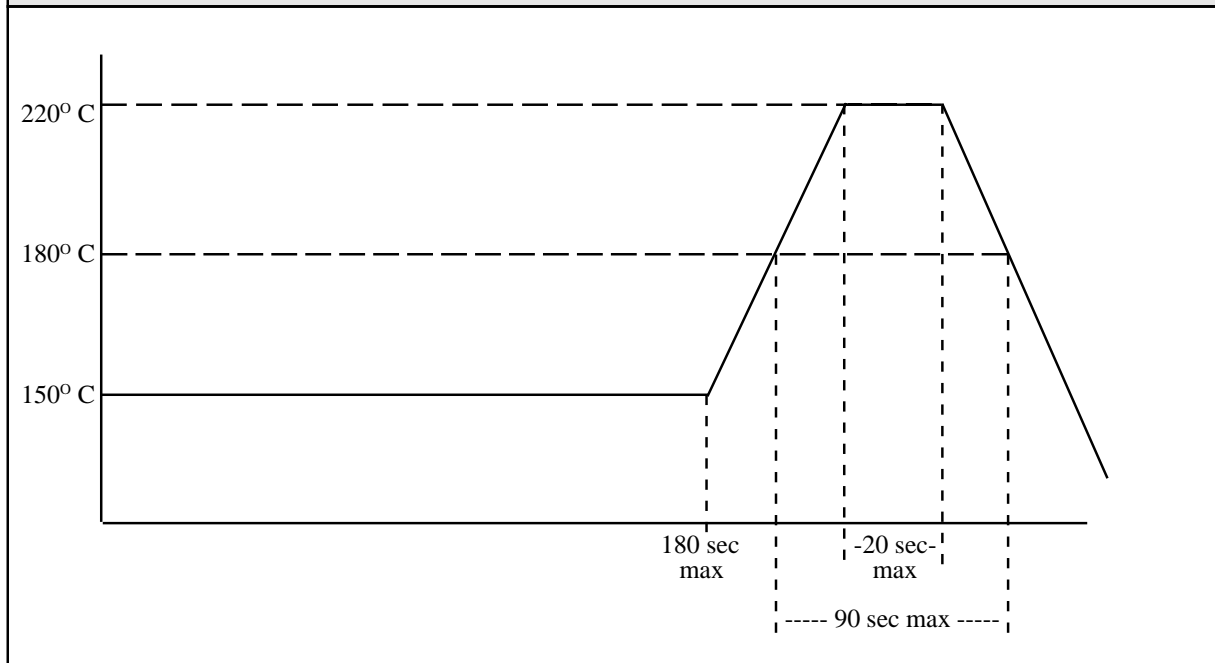

#### Notes:

Because of their large black bodies, Xecom's XE014JS DAA modules must not be exposed to direct Infrared Ray (IR) heating. If your process includes direct IR heating, you must shield the PLCC DAA module from the infrared rays.

Xecom's PLCC DAA modules should be exposed to no more than one reflow cycle.

## Typical Connection Diagram

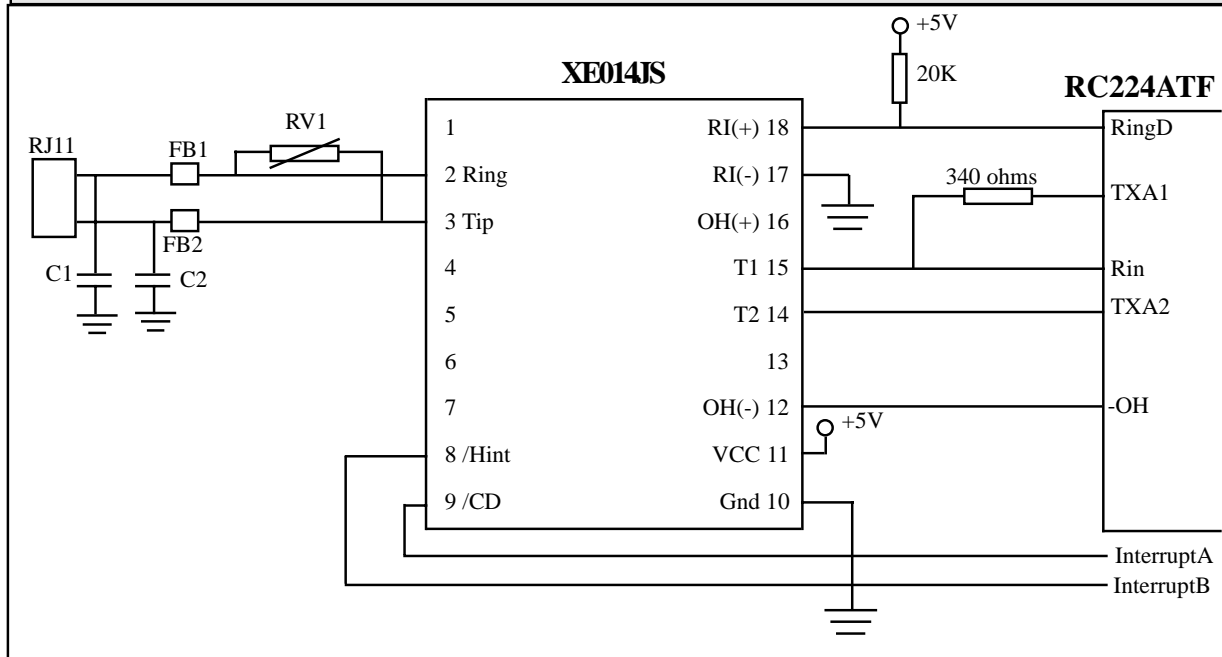

### Notes on Application Schematic:

C1 and C2 are 47 picofarad 1500 Volt Capacitors provided for EMI filtering. High voltage capacitors are required to maintain the isolation barrier between the telephone line and the host equipment.

FB1 and FB2 are Ferrite beads. They provide EMI filtering. They should present an impedance of at least 100 ohms at 100 MHz.

RV1 protects the XE014JS from voltage surges generated by near lightning strikes. Xecom recommends a Teccor Electronics P3100BA70 Sidactor. This device has a typical breakover voltage of 300 volts.

The 340 ohm resistor between T1 and TXA1 provides the optimal resistance for the XE014JS to match the impedance of a standard 600 ohm line.

---

## Application Notes

---

**Dialing:**

The public switched telephone network permits tone and rotary (pulse) dialing. The XE014JS supports both types of dialing. Tone dialing requires an external signal source to provide the dialing tones. Rotary dialing is accomplished by pulsing the OH or Mute line on the XE014JS.

**Pulse Dialing:** The XE014JS generates dialing pulses through momentary closures of the switch-hook. Each digit is represented as a series of pulses, one pulse for a one to ten pulses for a zero. The pulse rate is ten pulses per second. The dialing pulses are asymmetrical. An interdigit delay of at least one hundred milliseconds separates the digits.

**Tone Dialing:** To tone dial the XE014JS seizes the line, OH active. For each digit a unique DTMF, Dual Tone Multiple Frequency, tone pair is placed across T1 and T2. The higher frequency tone is always of greater magnitude than the lower frequency tone. Transmit the tones for a minimum of 70 milliseconds, and leave a minimum of 70 milliseconds between digits.

The table below shows the correct DTMF signal frequencies for each digit.

<u>Digit</u>	<u>Lower Tone</u>	<u>Upper Tone</u>
1	697	1209
2	697	1336
3	697	1477
4	770	1209
5	770	1336
6	770	1477
7	852	1209
8	852	1336
9	852	1477
0	941	1336
*	941	1209
#	941	1477

**Signal Levels:** FCC Part 68 Rules set the allowable signal level in the US for all signals placed on the telephone line other than live voice. Other countries have similar regulations. Signal levels are measured in dBm. Zero dBm is 1 milliwatt through a 600 ohm load.

**Insertion Loss:** There is some loss of signal power as the information signal passes through the XE014JS. This "insertion" loss should be taken into account when placing signals across T1 and T2 for transmission. The typical insertion loss of the XE014JS is 2.7 dBm.



## 2/4 Wire Convertor

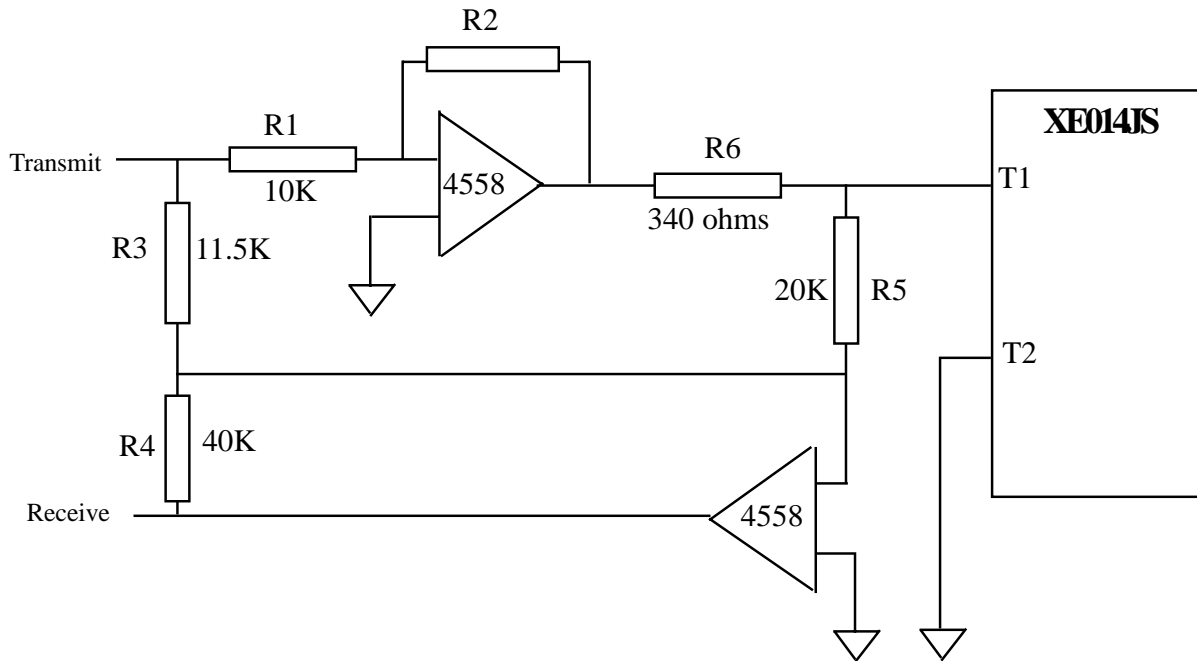

### 2/4 Wire Conversion:

Full Duplex communications over a two-wire telephone line requires that transmit and receive signal share the available bandwidth. The two-to-four wire convertor separates these signals at the host interface. Most modem analog front end chips incorporate an internal 2/4 wire convertor making it unnecessary to provide one in the DAA.

If you are using the XE014JS for an application other than a modem, such as voice processing, or your modem analog front end does not provide the 2/4 wire convertor, you will need to provide a discrete 2/4 wire convertor. The schematic on this page shows a simple 2/4 wire convertor circuit.

The performance of the 2/4 wire convertor is measured by its Transhybrid Loss. The Transhybrid Loss shows how much the 2/4 wire convertor attenuates the transmit signal on the received data line. The circuit above provides a typical Transhybrid Loss of 20 dB.

The Transhybrid Loss will vary with the quality of the impedance match to the telephone line. Even when the

recommended value for the impedance matching resistor, R6, is used variations from line to line alter the impedance match. The value of R3 can be changed to improve the Transhybrid Loss.

The 2/4 wire convertor also amplifies the transmit and receive signals to compensate for the insertion loss of the DAA. This circuit provides 6 dB gain of both the transmit and receive signals. The values of R1 and R2 set the transmit gain. The values of R4 and R5 set the receive gain.

---

---

## Telephone Line Connection Information

When developing a product to be connected to the telephone line, it is necessary to use a circuit known as a Data Access Arrangement (DAA) approved by the appropriate governmental agency. In the US this agency is the Federal Communications Commission (FCC), while in Canada it is Industry Canada (IC). These agencies test and approve the product to ensure that it meets their specifications, thereby protecting the telephone system from damage and protecting the user from high voltage transients (such as lightning strikes) which may come down the telephone line.

The XE014JS has been designed to meet all FCC Part 68 requirements for hazardous voltage, line impedance and leakage current. If the system transmits data, synthesized voice, or DTMF tones on the telephone line, the user must certify that the signals transmitted meet basic FCC requirements for maximum transmission levels, out of band energy and billing delay. Full details may be obtained from the FCC under Part 68 of the FCC Rules and Regulations, or in Title 47 of the Code of Federal Regulations, however the basic requirements are as follows:

### 1. Maximum Transmit Level

For the normal “permissive” (standard) telephone line, equipment which transmits data (such as a modem) must not exceed a transmission level of -9 dBm.

### 2. Out of Band Energy

Data equipment must not transmit “out of band” energy on the telephone line which exceeds the following limits:

<b>Frequency</b>		<b>Range</b>	<b>Max. Power</b>
3995 Hz	to	4005 Hz	-27 dBm
4005 Hz	to	12 kHz	-20 dBm
12 kHz	to	90 kHz	-55 dBm
90 kHz	to	270 kHz	-55 dBm
270 kHz	to	6 MHz	-15 dBm

### 3. DTMF Transmission Level

If the system is capable of DTMF dialing, the maximum DTMF transmission level must be less than 0 dBm averaged over a 3 second interval.

### 4. Billing Delay

A delay of 2 seconds or greater is required after the time the XE014JS is taken “off hook” and before any information is transmitted. This is required to ensure that billing information may be exchanged between telephone company central offices without interference.

OEM’s using the XE014JS must certify to the FCC that the final system meets the requirements of Part 68 which include the criteria above as well as the high voltage protection provided by the XE014JS. This is generally accomplished through an independent testing lab which tests the System and submits the proper paperwork to the FCC for approval. Since the XE014JS already complies with FCC Part 68 rules, this is a relatively simple process.

---

## Terms of Sale

Devices sold by XECOM are covered by the warranty provisions appearing in its Terms of Sale only. XECOM makes no warranty, express, statutory, implied, or by description regarding the information set forth herein, or regarding the freedom of the described devices from patent infringement. XECOM makes no warranty of merchantability or fitness for any purposes. XECOM reserves the right to discontinue production and change specifications and prices at any time and without notice. This product is intended for use in normal commercial applications. Applications requiring extended temperature range, unusual environmental requirements, or high reliability applications, such as military, medical life-support or life-sustaining equipment, are specifically not recommended without additional processing and authorization by XECOM for such application.

Xecom assumes no responsibility for the use of any circuitry other than circuitry embodied in a Xecom product. No other circuits, patents, or licenses are implied.

## Life Support Policy

Xecom's products are not authorized for use as Critical Components in Life Support Devices or Systems.

**Life Support Devices or Systems** are devices or systems which, (a) are intended for surgical implant into the body, or (b) support or sustain life, and whose failure to perform, when properly used in accordance with instructions provided in the labeling, can be reasonably expected to result in significant injury to the user.

**A Critical Component** is any component of a life support device or system whose failure to perform can be reasonably expected to cause failure of the life support device or system, or to affect its safety or effectiveness.

Copyright, Xecom © 1999

While Xecom, Inc. has made every effort to ensure that the information presented here is accurate, Xecom will not be liable for any damages arising from errors or omission of fact. Xecom reserves the right to modify specifications and/or prices without notice. Product mentioned herein are used for identification purposes only and may be trademarks and/or registered trademarks of their respective companies.



**Xecom Incorporated**  
374 Turquoise Street, Milpitas, CA 95035  
Ph:408-945-6640 Fax:408-942-1346  
Email: info@xecom.com