

**Multi-National 14,400 BPS Embeddable Modem**

**Description**

Xecom's XE1401 is a complete 14,400 bps modem in a single component. It is available for use in many countries throughout the world. Xecom offers versions for North America and Japan, Germany, France, Italy, and the United Kingdom.

The XE1401 is a complete modem including the DAA. XE1401 users do not need to add RAM, ROM, Crystals, transformers, or switches to complete the modem design. The user only needs to provide the TTL level, serial interface and the telephone jack.

The XE1401 is a full-featured modem. Besides the 14,400 bps data transfer, the XE1401 supports data compression, error correction and fax transfer. The XE1401 also includes NVRAM for permanent storage of the modem configuration.

The XE1401 is pin compatible with Xecom's XE2401L and XE3301 modems. This family of modems permits a simple upgrade path from 2400 bps to 33,600 bps.

**Features**

\* Models for North America, Japan, and Europe

<u>Country</u>	<u>Model</u>
Canada	XE1401
Japan	XE1401
France	XE1401F
Germany	XE1401G
Italy	XE1401I
UK	XE1401B
USA <sup>1</sup>	XE1401

\* Small Size: 2.75 inches by 1.38" by 0.42"

\* UL1459 Recognized

\* Modem Protocols: V.32bis (14,400 bps), V.32, V.22bis, V.22, V.21, Bell 212A and 103

\* Fax Protocols: V.17 (14,400 bps), V.29, V.27ter, and V.21 channel 2

\* Error Correction; V.42, MNP2-4 and MNP10

\* Data Compression; V.42bis and MNP5 provides a maximum effective data rate of 57,600 bps.

\* Pin compatible with Xecom's XE2401L and XE3301 modems

<sup>1</sup> (user transferable FCC Registration)

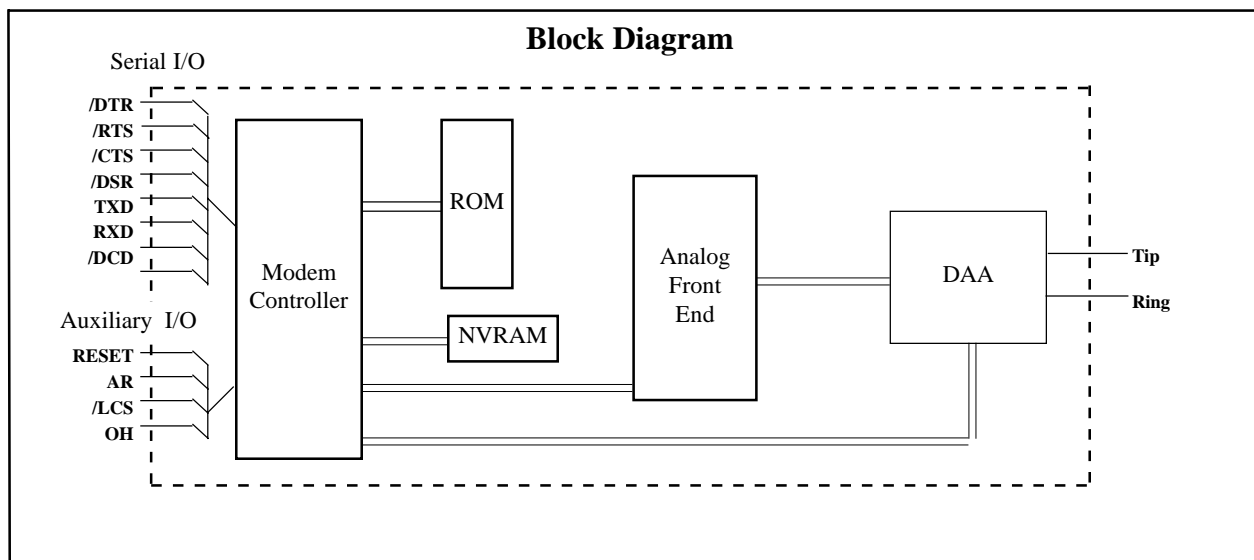

## XE1401 Mechanical Specifications

Dim	Inches		Metric (MM)	
	Min	Max	Min	Max
A	2.74	2.760	69.60	70.10
B	1.370	1.390	34.80	35.31
C	0.400	0.420	10.16	10.67
D	0.890	0.910	22.61	23.11
E	1.890	1.910	48.01	48.51
F	0.125	0.200	3.18	5.08
G	0.080	0.100	2.03	2.54
H	0.415	0.435	10.54	11.05
J	0.090	0.110	2.29	2.79
K	0.020	0.025	0.51	0.64
L	0.380	0.400	9.65	10.16
M	0.090	0.110	2.29	2.79

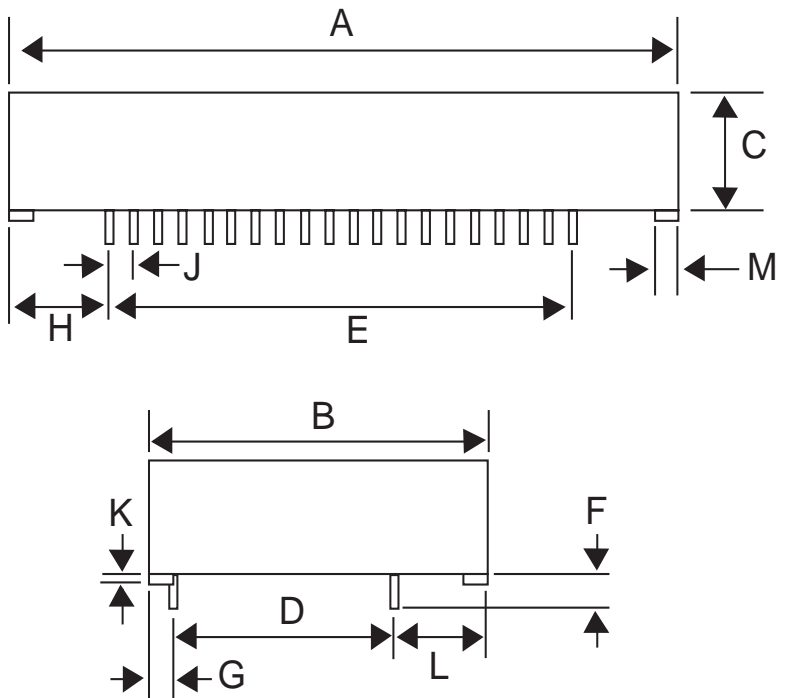

Pins = 0.025 inch square pin  
All pins tin-plated

## XE1401 PIN CONFIGURATION

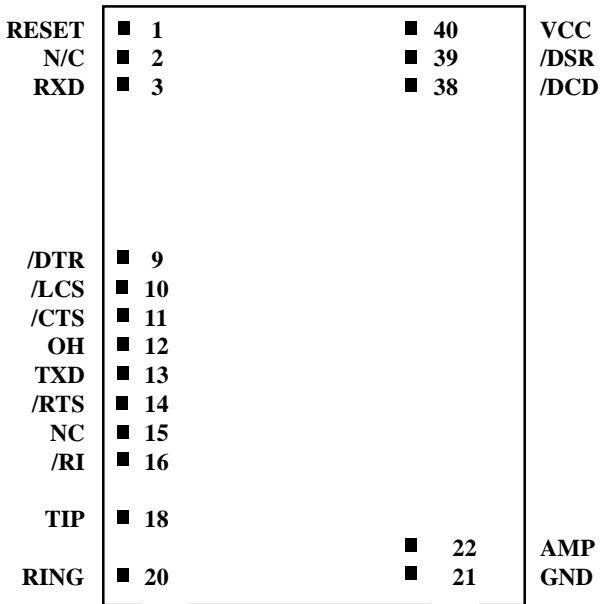

## XE1401 Pin Descriptions

PIN	NAME	DESCRIPTION
1	RESET	Hardware reset pin, Input, active High, TTL. A high on Pin 1 initiates a hardware reset. An external reset is not required or recommended. The Reset pulse must be a minimum of 100 milliseconds long.
2	N/C	No Internal Connection
3	RXD	Received Data, Output, TTL. Serial data output to the host. A logic "High" on RXD represents a "mark" and a logic "Low" represents a "space".
9	\DTR	Data Terminal Ready, Input, active Low, TTL. The "AT&D" command sets the function of \DTR. The default, AT&D2, requires the host to assert \DTR to permit a modem link. The modem drops the call in progress if \DTR is revoked and will not connect until \DTR is re-asserted.
10	\LCS	Loop Current Sense, active Low Input, TTL. A low on \LCS tells the modem that loop current is flowing through Tip and Ring. This feature is used only in the XE1401B version.
11	\CTS	Clear to Send, Output, active Low, TTL/CMOS. \CTS is used as a Flow Control output from the modem. The modem revokes \CTS with hardware flow control active to signal the host that the modem's input buffer is full. The modem reasserts \CTS when the buffer can accept more data without a buffer overflow.
12	OH	Off-Hook, Output, active High. OH indicates the modem's hookswitch relay is closed. Hookswitch closure connects the modem to the telephone line.
13	TXD	Transmit Data, Input, TTL. Serial data input from the host. A logic "High" represents a "mark" and a Low represents a "space", TTL.
14	\RTS	Request to Send, input, active LOW, TTL. The XE1401 uses \RTS for hardware flow control. When \RTS is revoked and hardware flow control is enabled, the modem will not place data on RXD.
15	NC	No Internal Connection
16	\RI	Ring Indicator, Output, active Low, TTL. When low indicates the modem is receiving a ring signal.
18	TIP	Tip connection to the phone line (RJ11 pin3) from the internal DAA. The XE1401 is not sensitive to the battery voltage polarity across Tip and Ring.
20	RING	Ring connection to the phone line (RJ11 pin4) from the internal DAA.
21	GND	Ground (0 volts)
22	AMP	Audio Output function is set by L & M commands and the value in register S22. This output can drive a minimum load of 300 ohms.

## XE1401 Pin Descriptions

PIN	NAME	DESCRIPTION
38	\DCD	Data Carrier Detect, Output, active Low, TTL/CMOS. AT&C sets the \DCD function. In the default condition, AT&C1, \DCD indicates the presence of a carrier signal on the telephone line.
39	\DSR	Data Set Ready, Output, active Low, TTL/CMOS. AT&S sets the \DSR function. In the default condition, AT&S0, \DSR is forced true.
40	Vcc	+5 Volts

ABSOLUTE MAXIMUM RATINGS*	
SUPPLY VOLTAGE - Vcc	+6.5 Volts
DC INPUT VOLTAGE	-0.6 Volts to +6.5 Volts
STORAGE TEMPERATURE RANGE	-25° C TO +85° C
LEAD TEMPERATURE (Soldering, 2 sec per wave)	260° C
OPERATING TEMPERATURE RANGE	0 TO 70° C
*Exceeding these values may result in permanent damage to the device.	

## XE1401 ELECTRICAL SPECIFICATIONS

Parameter	Min	Typ	Max	Units	Comments
VCC	4.75		5.25	Volts	
ICC	100	150	170	mamps	On Line
Ring Voltage Detected	38 10 20		150	RMS RMS RMS	XE1401 XE1401B, XE1401I XE1401G
Ring Frequency Detected	15.3		68	Hz	
Telephone Loop Current	10 10 10 10		100 120 60 45	mamps mamps mamps mamps	XE1401 XE1401B, XE1401I XE1401G XE1401F
Data Transmit level	-12	-10.5	-9.0	dBm	
DTMF Transmit Level		-2.5	0	dBm	Avg over 3 second interval
Billing tone Filter		16		KHz	XE1401G Only

## XE1401 Typical Applications Schematic

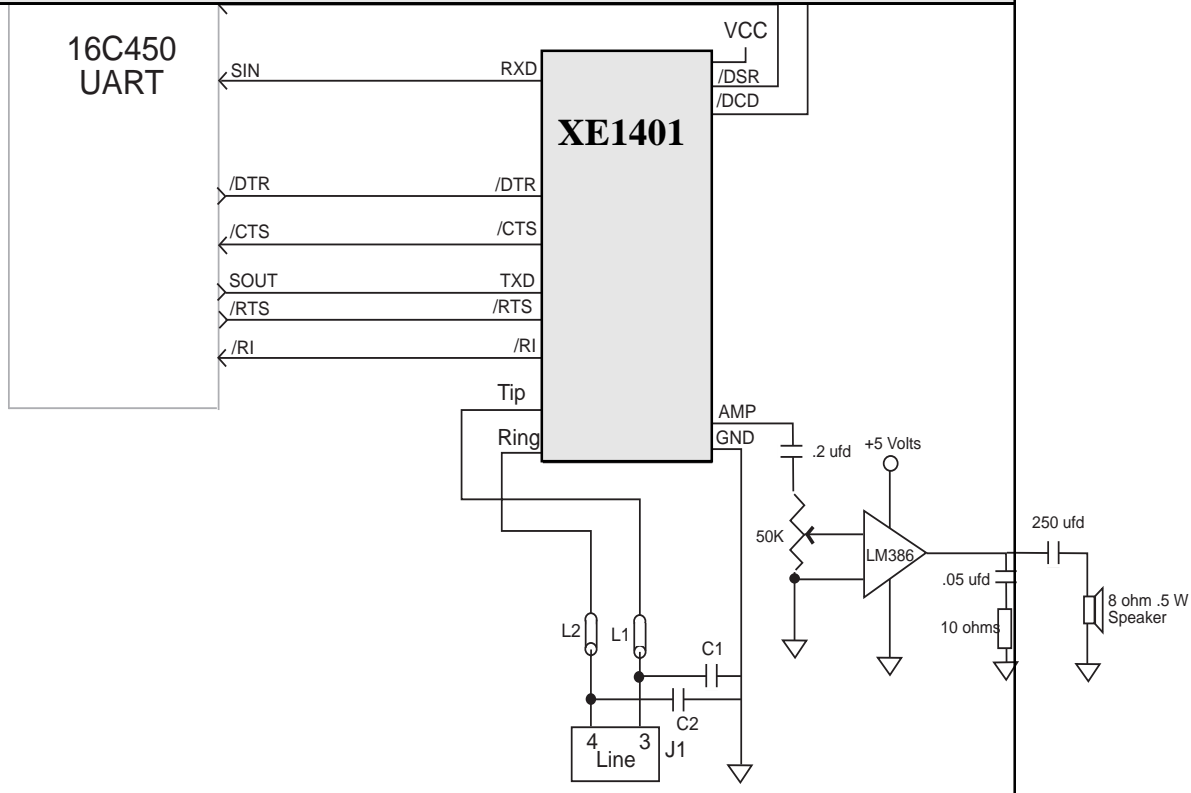

Note: RJ11 Pin assignments reflect a 6-pin connector. Tip and Ring are always the center pins of the RJ11 jack.

### Recommended Parts

<u>Reference Designation</u>	<u>Description</u>	<u>Recommended Part Number</u>
L1, L2	Ferrite Beads	TDK CB30-1812
C1, C2	Capacitors	Sprague 30GAT47, 470 pfd, 3000 Volts
J1	RJ11 Jack	Stewart SS6446NF

---

## XE1401 AT Commands

### Modes of Operation

The XE1401 uses "AT" commands for control and configuration. The XE1401 operates in three modes; Command Mode, Fax Mode and Data Mode. Extensions to the AT command set support fax operation.

**Data Mode:** The modem enters data mode after it establishes a link and issues a "CONNECT" result code. In Data Mode the modem modulates all signals on Transmit Data, Pin 13, and sends them to the remote modem. The modem demodulates the signal from the remote modem and places it onto Received Data, Pin 3, for the host equipment. When the modem exits data mode, it issues a "NO CARRIER" result code.

**Command Mode:** The XE1401 enters command mode on application of power, reset, loss of the connection, or receipt of the escape sequence. In command mode the modem accepts commands from the host on Transmit Data. Appropriate result codes are returned on Received Data at the same speed and parity as the commands.

**Fax Mode:** The modem enters fax mode on receipt of the AT+FCLASS=1 command. Fax commands and responses are issued at 19,200 bits per second; the character format is 8 bits no parity. The modem accepts Class 1 Fax commands only in fax mode. The A/, ATO, AT&T and escape commands are not valid in fax mode.

### Commands

The modem is configured and controlled with AT commands. AT commands follow a strict format. The command line is stored in the command buffer and executed upon receipt of a carriage return. Until executed, the command line can be edited with the backspace key.

**Command Format** - Each command, except A/, begins with the AT prefix. The "A" and "T" may be both upper case or both lower case but cannot be of different cases. The modem uses the prefix to identify the host's speed and parity. The modem determines speed by measuring the width of the incoming bits and parity by comparing the parity bits of the "A" and "T." The modem then returns result codes at the host's speed and parity.

**Command Line** - A command line may include multiple commands. The modem executes the commands in the sequence they appear in the command line. Spaces, inserted to improve legibility, do not fill space in the command buffer. A carriage return terminates the command line and causes the commands to be executed. Register S3 allows the user to select a character other than a carriage return to terminate the command line.

**Command Buffer** - The command buffer holds 40 characters, including the AT prefix. If it overflows, the modem issues an "ERROR" result code and commands are not executed.

**Command Line Editing** - A backspace can be used to edit the command any time before it is executed. The backspace character, Control and H simultaneously on some systems, erases the previous character in the command line. Any character except for the "A" and "T" can be erased. Register S5 allows the user to select a character other than a backspace to edit the command line.

**Re-Execute Last Command** - The A/ command causes the modem to re-execute the command line stored in the command buffer. This is the only command which does not require the "AT" prefix.

**Omitted Parameters** - Most commands include a parameter which determines the command function. When the parameter is omitted from the command string, it is assumed to be a 0.

**Escape Characters** - A three character escape sequence, entered while in data mode, will switch the modem into command mode while remaining on line. The escape character, set by Register S2, is entered 3 times in succession to execute the escape. The default escape sequence is "+++."

**Result Codes** - The modem issues a result code after each action. Result codes may be provided as full words, numeric codes or may be disabled. Each result code ends with a carriage return when numeric result codes are chosen. When full word result codes are chosen, a Line Feed and Carriage Return precede and follow each result code.

## **XE1401 AT Commands (continued)**

**List of Commands** An asterisk indicates the default setting of the command for the XE1401. The default setting may be different for the European models.

**A - Answer Command** - ATA forces the modem to immediately go off-hook and transmit answer tone.

**Bn - Select Communications Standard** - ATBn selects the modulation used for connections below 2400 bits per second

- n=0 Selects CCITT standards
- n=1 Selects Bell standards\*

**D - Dial Command** - Below are the characters accepted in a dialing command.

- 0-9, #, \* = Dialing Digits
- L = Re-dial last number
- P = Pulse dial
- T = Tone dial
- S=n = Dial stored number
- W = Wait for dial tone
- ^ = Toggles state of calling tone
- , = Pause for the duration of S8
- @ = Wait for silence
- ! = Switch hook flash
- ; = Return to the command state

**En - Command Echo** - ATEn determines whether commands will be echoed back to the host.

- n=0 Do not echo commands
- n=1 Enable command echo\*

**Hn - Switch Hook Control** - ATHn opens and closes the modem's hook switch.

- n=0 Switch hook relay opens
- n=1 The switch hook relay closes

**In - Modem Identification** - ATIn Identifies the version of the modem.

**Ln - Speaker Volume** - ATLn sets the amplitude of the modem's audio output.

- n=0 Lowest speaker volume
- n=1 Low speaker volume\*
- n=2 Moderate speaker volume
- n=3 High speaker volume

**Mn - Speaker Activity** - ATMn determines when the modem's audio output is active.

- n=0 Speaker off
- n=1 Speaker on until carrier received\*
- n=2 Speaker remains on
- n=3 Speaker off during dialing, on until carrier

**Nn - Data Rate** - ATNn selects whether or not the modem will negotiate a lower data link speed.

- n=0 Handshake only at DTE rate
- n=1 Negotiate highest common speed\*

**On - On Line** - ATOn switches the modem from the command mode to the data mode.

- n=0 Return On Line with no retrain\*
- n=1 Initiate retrain returning On Line.

**Qn - Responses** - ATQn determines if the modem will issue responses.

- n=0 Send responses\*
- n=1 No Responses

**Sr=n - Set Register Value** - ATsr=n sets the value of register Sr to n.

**Vn - Result Codes** - ATVn sets the modem to issue Numeric or Full Word result codes .

- n=0 Numeric Result Codes
- n=1 English Word Result Codes\*

**Wn - Connect Message Rate** - ATWn determines whether the data rate reported in the Connect response is the host data rate, the link data rate or whether both are provide along with the error control and data compression protocols negotiated.

- n=0 Send "CONNECT" at DTE Rate\*
- n=1 Report line speed, DTE speed and Link protocol
- n=2 "CONNECT" Reports Link speed

**Xn - Result Code Set** - ATXn selects which set of result codes the modem may send.

- n=0 Result codes 0 to 4
- n=1 Result codes 0 to 5 and 10
- n=2 Result codes 0 to 6 and 10
- n=3 Result codes 0 to 5, 7 and 10
- n=4 Full Result codes\*

## XE1401 AT Commands (continued)

**Yn - Long Space Disconnect** - ATYn sets the modem to disconnect on receipt of 1.6 seconds of continuous space.

- n=0 Long Space Disconnect Disabled\*
- n=1 Disconnect on long space

**Zn - Reset** - ATZn executes a soft reset to the modem and resets the modem configuration.

- n=0 Reset to user profile 0\*
- n=1 reset to user profile 1

**&Cn - DCD Operation** - AT&Cn determines the operation of the DCD output.

- n=0 DCD is forced active.
- n=1 DCD indicates a valid carrier\*

**&Dn - DTR** - AT&Dn determines how the modem will respond to changes to DTR.

- n=0 DTR is ignored by the modem.
- n=1 Enter command mode if DTR revoked.
- n=2 Disconnect if DTR revoked.\*
- n=3 Soft reset when DTR revoked

**&Fn - Return to Factory Defaults** - AT&Fn returns the modem configuration to one of two factory configurations.

- n=0 Restore configuration 0\*
- n=1 Restore configuration 1

**&Gn - Guard Tone** - AT&Gn controls the guard tone produced by the modem

- n=0 Guard Tone Disabled\*
- n=1 Guard Tone Disabled
- n=2 1800 Hz Guard Tone

**&Kn - Flow Control** - AT&Kn selects the flow control method used by the modem.

- n=0 Disabled
- n=3 RTS/CTS
- n=4 XON/XOFF
- n=5 Transparent XON/XOFF
- n=6 RTS/CTS and XON/XOFF

**&Pn - Dial Pulse Make/Break Ratio** - AT&Pn determines the specific pulse dialing parameters used by the modem.

- n=0 39/61% @ 10 pps\*
- n=1 33/67% @ 10 pps
- n=2 39/61% @ 20 pps
- n=3 33/67% @ 20 pps

**&Qn - Line Connection** - AT&Qn determines if error control or data buffering are active on the link.

- n=0 Direct mode (no data buffering)\*
- n=5 Use Error Correction
- n=6 Normal Mode (Speed buffering)

**&Sn - DSR Operation** - AT&Sn sets the operation of the DSR signal.

- n=0 DSR always active\*
- n=1 DSR in accordance with V.25.

**&Tn - Test Modes** - AT&T selects modem test modes.

- n=0 Exit test mode
- n=1 Local analog loopback
- n=3 Initiate local digital loopback
- n=4 Respond to remote loop request\*
- n=5 Deny remote loop request
- n=6 Initiate a Remote Digital loopback
- n=7 Remote digital loopback w self-test
- n=8 Local analog loopback w self-test

**&Vn - View Configuration Profiles** - AT&V permits the user to check on the modems current configuration.

- n=0 View active profile & user profile 0\*
- n=1 View active profile & user profile 1

**&Wn - Store Active Profile** - AT&Wn stores the current modem configuration in NVRAM.

- n=0 Store active profile as profile 0\*
- n=1 Store active profile as profile 1

**&Yn - Recall Stored Profile** - AT&Yn sets the stored modem configuration to be used after a hard reset.

- n=0 Recall profile 0 on power-up\*
- n=1 Recall profile 1 on power-up

**&Zn=x - Store phone number "x" in memory location "n"**

**%En - Line Quality Monitor/Auto Retrain** - AT%En determines if the modem monitors line quality during a connection and initiate a retrain if quality drops below acceptable levels.

- n=0 Disabled
- n=1 Enabled
- n=2 Line quality, fallback, fall forward



## XE1401 AT Commands (continued)

**%L - Read Received Signal Level** - AT%L permits the user to read the magnitude of the received signal in dBm.

**%Q - Read Line Signal Quality** - AT%Q permits the user to read the EQM value of the received signal.

**\An - MNP Block Size** - AT\An sets the block size for MNP data packets.

- n=0 Maximum 64 characters
- n=1 Maximum 128 characters
- n=2 Maximum 192 characters
- n=3 Maximum 256 characters\*

**\Bn - Transmit Break** - AT\Bn selects the duration of the break signal sent. Break = n x 100 msec.

**\Kn - Break control** - AT\Kn determines how the modem will handle a break signal.

**Break received from host with Reliable link.**

- n=0 Enter on-line command mode; do not transmit break
- n=1 Purge buffers, immediately transmit break
- n=2 Same as n=0
- n=3 Immediately send break
- n=4 same as n=0
- n=5 Send break in sequence with data\*

**Break received from host with Direct link .**

- n=0 transmit break, then enter on-line command mode
- n=1 Immediately send break
- n=2 Enter command mode; do not transmit break signal
- n=3 same as n=1
- n=4 same as n=0
- n=5 same as n=1\*

**Break received from modem w Normal link.**

- n=0 Purge buffers, Immediately send break to the host
- n=1 same as n=0
- n=2 Immediately send break to the host
- n=3 Same as n=2
- n=4 Send break in sequence with data.
- n=5 Same as n=2\*

**Host initiates break with \B command on Reliable link.**

- n=0 Purge buffers and immediately transmit break
- n=1 Same as n=0
- n=2 Immediately transmit break
- n=3 Same as n=1
- n=4 Transmit break in sequence with data
- n=5 Same as n=4

**\Nn - Error Correction Selection** - AT\Nn determines how the modem handles error control negotiations.

- n=0 Normal Mode, no error correction
- n=1 Direct Mode, no data buffering, no error correction
- n=2 Reliable Mode, error correction required
- n=3 Auto Reliable Mode, accept either error controlled or non-error controlled links
- n=4 V42 Reliable Mode, LAPM required
- n=5 MNP Reliable Mode, MNP required

**\Vn - Single Line Result Codes** - AT/Vn determines if the Connect response is issued in a single line format. The single line format is shown. CONNECT<DTE Speed><Modulation><Protocol><Compression><Link Speed>

- n=0 Responses per ATX, ATW and S95\*
- n=1 Single Line Responses

**-Kn - MNP Extended Services** - AT-Kn determines how the modem handles MNP10.

- n=0 No LAPM to MNP10 conversion
- n=1 LAPM to MNP10 conversion\*
- n=2 LAPM to MNP10 conversion but no MNP Extended Service during V.42 LAPM answer mode detect.

**-SEC=n,t** - MNP10-EC This command controls the error correction protocol for cellular links, MNP10-EC.

- n=0 No MNP10-EC error correction supported
- n=1 Enable MNP10-EC protocol with Transmit Level at -t dBm where t can be any value from 0 to 30.

## **XE1401 Result Codes**

<b>Digits</b>	<b>Verbose</b>	<b>Description</b>	<b>Digits</b>	<b>Verbose</b>	<b>Description</b>
0	OK	Successfully executed command line	46	CARRIER 1200	1200 bps carrier received
1	CONNECT	300 bps connection	47	CARRIER 2400	2400 bps carrier received
2	RING	Ring signal detected	48	CARRIER 4800	4800 bps carrier received
3	NO CARRIER	Carrier not detected/lost	49	CARRIER 7200	7200 bps carrier received
4	ERROR	Error in command line	50	CARRIER 9600	9600 bps carrier received
5	CONNECT 1200	1200 bps connection	51	CARRIER 12000	12,000 bps carrier received
6	NO DIAL TONE	No dial tone detected	52	CARRIER 14400	14,400 bps carrier received
7	BUSY	Busy signal detected	66	COMPRESSION: CLASS 5	MNP5 data compression
8	NO ANSWER	5 second silence not detected	67	COMPRESSION: V.42bis	V.42bis data compression
10	CONNECT 2400	2400 bps Connection	69	COMPRESSION: NONE	No data compression
11	CONNECT 4800	4800 bps Connection	70	PROTOCOL: NONE	No error correction
12	CONNECT 9600	9600 bps Connection	77	PROTOCOL: LAPM	LAPM error correction
13	CONNECT 7200	7200 bps Connection	80	PROTOCOL: ALT	MNP error correction
14	CONNECT 12000	12,000 bps Connection	81	PROTOCOL: ALT CELLULAR	MNP10 error correction
15	CONNECT 14400	14,400 bps Connection	+F4	+FCERROR	Fax carrier error
16	CONNECT 19200	19,200 bps Connection			
17	CONNECT 38400	38,400 bps Connection			
22	CONNECT 75TX/1200RX	V.23 originate connection			
23	CONNECT 1200TX/75RX	V.23 answer connection			
33	FAX	Fax connection			
35	DATA	Data connection in Fax mode			
40	CARRIER 300	300 bps carrier received			
44	CARRIER 1200/75	V.23 reverse channel carrier received			
45	CARRIER 75/1200	V.23 forward channel carrier received			

## XE1401 Class 1 Fax Commands

### AT+FCLASS? - Service Class Indication

- n=0 Configured as a data modem
- n=1 Configured for Service Class 1.

### AT+FCLASS=? - Shows Service Class Capability

- n=0 Configured as a data modem
- n=1 Configured for Service Class 1.

### AT+FCLASS=n - Sets Service Class

- n=0 Configured as a data modem
- n=1 Configured for Service Class 1.

### AT+FAE=n - Selects Data/Fax Auto Answer

- n=0 Answer as a fax modem only
- n=1 Either a fax or data modem

### AT+FRS=n - Receive Silence

This command causes the modem to issue an OK response after detecting silence for n \* 10 milliseconds.

### AT+FTS=n - Stop Transmission and Wait

This command causes the modem to stop transmission for n \* 10 milliseconds before issuing the OK response

### AT+FRH=n - Receive HDLC Data Frames

- n=3 V.21 Channel 2, 300 bps
- n=24 V.27ter, 2400 bps
- n=48 V.27ter, 4800 bps
- n=72 V.29, 7200 bps
- n=73 V.17, long training, 7200 bps
- n=74 V.17, short training, 7200 bps
- n=96 V.29, 9600 bps
- n=97 V.17, long training, 9600 bps
- n=98 V.17 short training, 9600 bps
- n=121 V.17, long training, 12,000 bps
- n=122 V.17 short training, 12,000 bps
- n=145 V.17, long training, 14,400 bps
- n=146 V.17 short training, 14,400 bps

### AT+FRM<mod> - Receive Fax

- n=24 V.27ter, 2400 bps
- n=48 V.27ter, 4800 bps
- n=72 V.29, 7200 bps
- n=73 V.17, long training, 7200 bps
- n=74 V.17, short training, 7200 bps
- n=96 V.29, 9600 bps
- n=97 V.17, long training, 9600 bps
- n=98 V.17 short training, 9600 bps
- n=121 V.17, long training, 12,000 bps
- n=122 V.17 short training, 12,000 bps
- n=145 V.17, long training, 14,400 bps
- n=146 V.17 short training, 14,400 bps

### AT+FTH=n- Transmit HDLC Data

- n=3 V.21 Channel 2, 300 bps
- n=24 V.27ter, 2400 bps
- n=48 V.27ter, 4800 bps
- n=72 V.29, 7200 bps
- n=73 V.17, long training, 7200 bps
- n=74 V.17, short training, 7200 bps
- n=96 V.29, 9600 bps
- n=97 V.17, long training, 9600 bps
- n=98 V.17 short training, 9600 bps
- n=121 V.17, long training, 12,000 bps
- n=122 V.17 short training, 12,000 bps
- n=145 V.17, long training, 14,400 bps
- n=146 V.17 short training, 14,400 bps

### AT+FTM<mod> - Transmit Fax

- n=24 V.27ter, 2400 bps
- n=48 V.27ter, 4800 bps
- n=72 V.29, 7200 bps
- n=73 V.17, long training, 7200 bps
- n=74 V.17, short training, 7200 bps
- n=96 V.29, 9600 bps
- n=97 V.17, long training, 9600 bps
- n=98 V.17 short training, 9600 bps
- n=121 V.17, long training, 12,000 bps
- n=122 V.17 short training, 12,000 bps
- n=145 V.17, long training, 14,400 bps
- n=146 V.17 short training, 14,400 bps

## XE1401 AT Registers

### S-Registers

Following are descriptions of the S-Registers Supported by the XE1401.

**S0 Answer on nth Ring:** S0 sets the modem to automatically answer on the nth ring. Setting S0 to 0 disables automatic answer.

Range: 0 to 255  
Units Rings  
Default 0

**S1 Ring Count:** S1 is a read-only register. It shows the number of rings detected. If a ring is not detected within 8 seconds, the counter is reset to zero.

Range: 0 to 255  
Units Rings  
Default 0

**S2 Escape Character:** S2 determines the ASCII character used in the escape sequence. Values of 0-127 select valid ASCII escape characters; values from 128 to 255 disable the escape sequence.

Range: 0 to 255  
Units ASCII Character  
Default 43 (+)

**S3 Carriage Return Character:** S3 determines the ASCII character to serve as a carriage return to terminate commands and to be inserted in modem responses.

Range: 0 to 127  
Units ASCII Character  
Default 13 (Carriage Return)

**S4 Line Feed Character:** S4 sets the ASCII character to act as a line feed character in modem responses.

Range: 0 to 127  
Units ASCII Character  
Default 10 (Line Feed)

**S5 Back Space Character:** S5 defines the ASCII character used as a backspace to edit the command line.

Range: 0 to 32  
Units ASCII Character  
Default 8 (Back Space)

**S6 Dial Tone Wait Time:** S6 determines how long the modem waits for dial tone before dialing begins. The Dial Tone Wait Time cannot be set to less than two seconds.

Range: 2 to 255  
Units Seconds  
Default 2

**S7 Wait for Carrier after Dialing:** S7 determines how long the modem waits for a valid carrier signal after dialing is completed.

Range: 1 to 255  
Units Seconds  
Default 50

**S8 Comma Pause Time:** S8 defines the duration of the pause initiated by a comma in the dialing string. The pause is generally used when waiting for a second dial tone.

Range: 1 to 255  
Units Seconds  
Default 50

**S9 Carrier Detect Response Time:** S9 establishes the length of time the remote modem's carrier must be present to be recognized as valid.

Range: 1 to 255  
Units 0.1 Seconds  
Default 6

**S10 Carrier Off Disconnect Delay:** S10 selects how long carrier must be lost before the modem disconnects. Note: If S10 is smaller than the value of S9, the modem will not automatically disconnect on loss of carrier.

Range: 1 to 255  
Units 0.1 Seconds  
Default 14

**S11 Tone Dialing Speed:** S11 sets the duration and spacing of the dialing tones. S11 does not affect the pulse dialing rate.

Range: 50 to 255  
Units 1 Millisecond  
Default 95

## XE1401 AT Registers (continued)

**S12 Escape Code Guard Timer:** S12 sets the escape sequence guard timer. If characters are received before or after the escape sequence, within the guard timer, the modem aborts the escape attempt and remains in data mode.

Range: 0 to 255  
Units 0.02 Seconds  
Default 50

**S14 General Bit-Mapped Options:** S14 reflects the state of several "AT" commands.

Bit 0,4,6 Not Used  
Bit 1 0 = Echo Disabled (ATE0)  
1 = Echo Active (ATE1)  
Bit 2 0 = Send Result Codes (ATQ0)  
1 = No Result Codes (ATQ1)  
Bit 3 0 = Numeric Result Codes (ATV0)  
1 = Full Word Result Codes (ATV1)  
Bit 5 0 = Tone Dialing Selected (T)  
1 = Pulse Dialing Selected (P)  
Bit 7 0 = Answer  
1 = Originate

**S16 Test Status:** S16 shows the test status of the modem

Bit 0 0 = No Local Analog Loopback  
1 = Local ALB Active  
Bit 1 Not Used  
Bit 2 0 = Local Digital Loopback Disabled  
1 = Local DLB Enabled  
Bit 3 0 = No Remote Digital Loopback  
1 = Remote DLB Active  
Bit 4 0 = Remote DLB not requested  
1 = Remote DLB Requested  
Bit 5 0 = Remote DLB w Self-Test Disabled  
1 = Remote DLB w Self-Test Enabled  
Bit 6 0 = Local ALB w Self-Test Disabled  
1 = Local ALB w Self-Test Enabled  
Bit 7 Not Used

**S18 Test Timer:** S18 determines the duration of any test. If S18 equals 0, the AT&T0 command terminates the test.

Range: 0 to 255  
Units Seconds  
Default 0

**S21 General Bit-Mapped Options:** S21 reflects the state of several "AT" commands.

Bit 0-2 Not Used  
Bit 3,4 0 = DTR ignored (AT&D0)  
1 = Enter command mode on DTR off (AT&D1)  
2 = Disconnect on DTR off (AT&D2)  
3 = Reset on DTR off (AT&D3)  
Bit 5 0 = DCD always active (AT&C0)  
1 = DCD on with Carrier (AT&C1)  
Bit 6 0 = DSR always active (AT&S0)  
1 = DSR on when modem ready (&S1)  
Bit 7 0 = No disconnect on Space (ATY0)  
1 = Disconnect on Space (ATY1)

**S22 General Bit-Mapped Options:** S22 reflects the state of several "AT" commands.

Bit 0-1 0 = Low speaker volume (ATL0)  
1 = Low speaker volume (ATL1)  
2 = Moderate speaker volume (ATL2)  
3 = High speaker volume (ATL3)  
Bit 2-3 0 = Speaker off (ATM0)  
1 = Speaker off with carrier (ATM1)  
2 = Speaker always on (ATM2)  
3 = Speaker on during handshake (ATM3)  
Bit 4-6 0 = Basic Result codes (ATX0)  
4 = Connect speed result codes (ATX1)  
5 = No Blind Dial (ATX2)  
6 = Busy Detection (ATX3)  
7 = Full result codes (ATX4)  
Bit 7 Not Used

## XE1401 AT Registers (continued)

- S23 General Bit-Mapped Options:** S23 reflects the state of several "AT" commands.
- Bit 0 0 = Remote DLB Disabled (AT&T5)  
1 = Remote DLB Allowed (AT&T4)
  - Bit 1-3 0 = Host Interface at 300 bps  
1 = Host Interface at 600 bps  
2 = Host Interface at 1200 bps  
3 = Host Interface at 2400 bps  
4 = Host Interface at 4800 bps  
5 = Host Interface at 9600 bps  
6 = Host Interface at 19200 bps  
7 = Host I/F at 38400 bps or higher
  - Bit 4-5 0 = Even parity in use  
1 = Not used  
2 = Odd Parity in use  
3 = No Parity in use
  - Bit 6-7 0 = No Guard Tone (AT&G0)  
1 = No Guard Tone (AT&G1)  
2 = 1800 Hz guard tone (AT&G2)  
3 = Not Used
- S27 General Bit-Mapped Options:** S27 reflects the state of several "AT" commands.
- Bit 0 1 3  
0 0 0 = Normal Mode (AT&Q0)  
1 0 1 = Error control enabled (AT&Q5)  
0 1 1 = Direct Mode (AT&Q6)
  - Bit 2, 4-5, 7 Not Used
  - Bit 6 0 = CCITT Protocols (ATB0)  
1 = Bell Protocols (ATB1)
- S28 Pulse Dialing Bit-Mapped Options:** S28 stores the modem's pulse dialing configuration.
- Bit 0-2, 5-7 Not Used
  - Bit 3-4 0 = Make/Break ratio 39%/61%; 10 pulses per second (AT&P0)  
1 = Make/Break ratio 33%/67%; 10 pulses per second (AT&P1)  
2 = Make/Break ratio 39%/61%; 20 pulses per second (AT&P2)  
3 = Make/Break ratio 33%/67%; 20 pulses per second (AT&P3)
- S29 Hook Flash Timer:** S29 determines the length of time the modem closes its off-hook relay to simulate a hook switch flash on receipt of the "!" dial modifier stores the modem's pulse dialing configuration.
- Range: 0 to 255
  - Units: 10 milliseconds
  - Default 70
- S30 Disconnect on Inactivity Timer:** S30 sets the time the modem is idle before it automatically disconnects. A 0 disables the inactivity timer.
- Range: 0 to 255
  - Units 10 Seconds
  - Default 0
- S31 General Bit-Mapped Options:** S31 stores the status of various AT commands.
- Bit 0 0 = No single-line Connect messages (AT\V0)  
1 = Use single-line Connect messages (AT\V1)
  - Bit 1 0 = No Automode detection (ATN0)  
1 = Automode detection active (ATN1)
  - Bit 2-3 0 = Report host speed (ATW0)  
1 = Report all parameters (ATW1)  
2 = Report modem speed only (ATW2)
  - Bit 4-7 Not Used
- S32 XON Character:** S32 determines the ASCII character to be sent as XON for in-band flow control.
- Range: 0 to 255
  - Units ASCII Character
  - Default 11 (VT)
- S33 XOFF Character:** S32 determines the ASCII character recognized as XOFF for in-band flow control.
- Range: 0 to 255
  - Units ASCII Character
  - Default 19 (DC3)
- S36 LAPM Failure:** S36 instructs the modem what to do if the error control negotiations fail.
- Bit 0-2 0 = Modem Disconnects  
1 = Establish Direct Connection  
3 = Establish normal Connection  
4 = Disconnect if MNP handshake fails  
5 = Establish Direct Connection if MNP handshake fails.  
7 = Establish Normal Connection if MNP handshake fails.
  - Bit 3-7 Not Used

## XE1401 AT Registers (continued)

- S37 Desired Line Speed:** S37 sets the speed at which the modem begins link negotiations.
- Bits 0-4
- 0 = Automode Connection\*
  - 1-3 = 300 BPS (V.21, Bell 103)
  - 4 = Reserved
  - 5 = 1200 BPS (V.22, Bell 212A)
  - 6 = 2400 BPS (V.22bis)
  - 7 = 1200 Fwd/75 Bwd (V.23)
  - 8 = 4800 BPS (V.32, V.32bis)
  - 9 = 9600 BPS (V.32, V.32bis)
  - 10 = 12,000 BPS (V.32bis)
  - 11 = 14,400 BPS (V.32bis)
  - 12 = 7200 BPS (V.32bis)
- Bits 5-7 Reserved
- S38 Forced Disconnect Timer:** S38 sets the delay between receipt of the disconnect command and the opening of the switch hook. If S38 is set to 255 the modem disconnects only after its buffers are empty.
- Range: 0 to 255  
Units 1 Second  
Default 20
- S39 Flow Control Bit-Mapped Options:** S39 shows the status of the modem's flow control options, AT&K.
- Bit 0-2
- 0 = Flow Control Disabled
  - 3 = Hardware Flow Control, RTS/CTS
  - 4 = In-Band Flow Control XON/XOFF
  - 5 = Transparent In-Band Flow Control
  - 6 = Both Hardware and In-Band Flow Control
- Bit 3-7 Not used
- S40 MNP Bit-Mapped Options:** S40 shows the status of the modem's MNP commands, .
- Bit 0-1
- 0 = No LAPM-MNP10 conversion (-K0)
  - 1 = Enable LAPM-MNP10 conversion (-K1)
  - 2 = Enable LAPM-MNP10 conversion except for LAPM answer mode (-K1)
- Bit 2 Not Used
- Bit 3-5
- 0 = AT\K0 break handling selected
  - 1 = AT\K1 break handling selected
  - 2 = AT\K2 break handling selected
  - 3 = AT\K3 break handling selected
  - 4 = AT\K4 break handling selected
  - 5 = AT\K5 break handling selected
- Bit 6-7
- 0 = MNP Block size 64 characters
  - 1 = MNP Block size 128 characters
  - 2 = MNP Block size 192 characters
  - 3 = MNP Block size 256 characters
- S41 General Bit-Mapped Options:** S41 stores the condition of various "AT" commands.
- Bit 0-1
- 0 = No Data Compression (AT%C0)
  - 1 = MNP5 Data Compression (AT&C1)
  - 2 = V.42bis Data Compression (AT&C2)
  - 3 = Either MNP5 or V.42bis Data Compression (AT&C3)
- Bit 2, 6
- 0 0 = No Fallback/Forward (AT%E0)
  - 1 0 = Retrain Enabled (AT%E1)
  - 0 0 = Fallback/Forward Enabled (AT%E2)
- Bit 3-5, 7 Not Used
- S46 Data Compression Control:** S46 selects whether or not the modem will support data compression with error control.
- S46=136 No data compression  
S46=138 Data Compression selected  
Default 138
- S48 V.42 Negotiations:** S48 determines the modem's V.42 negotiation process.
- S48=0 Proceed with LAPM  
S48=7 Negotiate per V.42  
S48=128 Assume LAPM failure  
Default 7

---

**XE1401 AT Registers (continued)**

- S86 **Call Failure Code:** S86 shows why the last "NO CARRIER" response was issued.
- S86=0 Normal Disconnect
  - S86=4 Loss of Carrier
  - S86=5 V.42 Negotiation Failure
  - S86=9 Modem Handshake Failure
  - S86=12 Disconnect Initiated by remote modem
  - S86=13 No response after 10 retries
  - S86=14 Protocol Violation
- S95 **Extended Result Codes:** S95 permits the user to customize the extended result codes.
- Bit 0 Connect result code shows link speed
  - Bit 1 Add /ARQ to connect response
  - Bit 2 Add /VFC to Carrier response
  - Bit 3 Enable Protocol response
  - Bit 4 Not Used
  - Bit 5 Enable Compression Result Code
  - Bit 6 Not used
  - Bit 7 Not Used



---

---

## FCC Part 68 Information

All equipment connected to the public telephone network in the United States must have FCC Part 68 Registration. Part 68 registration certifies that the device will not cause harm to the telephone network. The XE1401 provides a user transferable FCC Registration. This permits XE1401 customers to use our FCC registration number without submitting their systems for additional testing. Call Xecom technical support at 408-945-6640 with any questions on whether your system qualifies to use Xecom's FCC Registration Number.

In your operating instructions you must provide certain information to the end user of the modem. The instructions should include most of the instructions shown below. Only the information regarding the mounting of the device in the final assembly should be omitted.

### **FCC Instructions:**

This product complies with Part 68 of the FCC Rules and Regulations. On each device shipped, there is a label which contains, among other information, the FCC Registration Number and Ringer Equivalence Number (REN) for this product. You must, upon request, provide this information to your telephone company.

The mounting of this device in the final assembly must be made in such a manner as to preserve the high voltage protection between the TIP/RING Connection and the rest of the system. Typically, this may be accomplished by maintaining a minimum spacing .100 mils between the TIP/RING Traces to the RJ-11C Jack and low voltage portion of the system. No additional circuitry may be attached between TIP/RING and the telephone line connection, unless specifically allowed in the rules.

The REN is useful to determine the quantity of devices you may connect to a telephone line and still have all of these devices ring when the number is called. In most, but not all areas, the sum of the RENs of all devices connected to one line should not exceed five (5.0). To be certain of the number of devices you may connect to the line, as determined by the REN, you should contact the local telephone company to determine the maximum REN for your calling area.

If your system causes harm to the telephone network, the telephone company may discontinue service temporarily. If possible, they will notify you in advance. If advance notification is not practical, you will be notified as soon as possible.

Your telephone company may make changes in its facilities, equipment, operations or procedures that could affect proper functioning of your equipment. If they do, you will be notified in advance to give you an opportunity to maintain uninterrupted telephone service.

If you experience trouble with this device, please contact XECOM at (408) 945-6640 for assistance. The telephone company may ask you to disconnect this device from the network until the problem has been corrected or until you are sure that the device is not malfunctioning.

The device may not be used on coin service lines provided by the telephone company (this does not apply to private coin telephone applications which use standard telephone lines). Connection to party lines is subject to state tariffs.

### **FCC Labels:**

FCC rules also require a label which is visible from the outside of the equipment. The label should display Xecom's name as holder of the FCC Registration, the FCC Registration Number and Ringer Equivalence of the modem. This is the same information which appears on the top of each XE1401 module.

## Terms of Sale

Devices sold by XECOM are covered by the warranty provisions appearing in its Terms of Sale only. XECOM makes no warranty, express, statutory, implied, or by description regarding the information set forth herein, or regarding the freedom of the described devices from patent infringement. XECOM makes no warranty of merchantability or fitness for any purposes. XECOM reserves the right to discontinue production and change specifications and prices at any time and without notice. This product is intended for use in normal commercial applications. Applications requiring extended temperature range, unusual environmental requirements, or high reliability applications, such as military, medical life-support or life-sustaining equipment, are specifically not recommended without additional processing and authorization by XECOM for such application.

Xecom assumes no responsibility for the use of any circuitry other than circuitry embodied in a Xecom product. No other circuits, patents, or licenses are implied.

## Life Support Policy

Xecom's products are not authorized for use as Critical Components in Life Support Devices or Systems.

**Life Support Devices or Systems** are devices or systems which, (a) are intended for surgical implant into the body, or (b) support or sustain life, and whose failure to perform, when properly used in accordance with instructions provided in the labeling, can be reasonably expected to result in significant injury to the user.

A **Critical Component** is any component of a life support device or system whose failure to perform can be reasonably expected to cause failure of the life support device or system, or to affect its safety or effectiveness.

Copyright, Xecom © 1999

While Xecom, Inc. has made every effort to ensure that the information presented here is accurate, Xecom will not be liable for any damages arising from errors or omission of fact. Xecom reserves the right to modify specifications and/or prices without notice. Product mentioned herein are used for identification purposes only and may be trademarks and/or registered trademarks of their respective companies.



**Xecom Incorporated**  
374 Turquoise Street, Milpitas, CA 95035  
Ph:408-945-6640 Fax:408-942-1346  
EMail [info@xecom.com](mailto:info@xecom.com)  
Web Site [www.xecom.com](http://www.xecom.com)