

Worldwide 14.4 KBPS Modem Module for Embedded Applications

Description

Xecom's XE1414C is a complete, 14.4 Kbps modem in a single component. Xecom designed the XE1414C for use throughout North America, Europe and Japan. It includes user transferrable FCC Part 68 Registration for direct connection to telephone lines in the United States and is compliant with CTR21.

The XE1414C is a complete modem packaged in a compact module. The XE1414C includes all required modem circuits including the DAA. XE1414C users do not need to add RAM, ROM, Crystals, low distortion transformer, or switches to complete the modem design. The user only needs to provide the TTL level, serial interface and the telephone line connection.

The XE1414C is pin compatible with Xecom's XE3314C modem. This family of modems permits a simple upgrade path from 14,400 bps to 33,600 bps for international embedded modem applications.

Features

- Meets telecom requirements for Europe, North America, and Japan: Includes User Transferrable FCC Part 68 Registration and CTR21 compliance
- Small Size: 2.75 inches by 1.38 inches by 0.42 inches;
- Modem Protocols support data transfer from 300 BPS to 14.4 KBPS: V.32bis, V.32, V.22bis, V.22, V.21, Bell 212A and 103;
- Modem Control and Configuration via AT Commands
- Fax Protocols: V.17, V.29, V.27ter, and V.21 channel 2
- Error Correction; V.42, MNP2-4 and MNP10
- Data Compression; V.42bis and MNP5 provides a maximum effective data rate of 57,600 bps.
- Non-Volatile Memory included for storing telephone numbers and modem configuration.
- Standard operating temperature range 0C to 70C. Extended range of -40C to +85C is available.
- Supports Leased Line Applications.

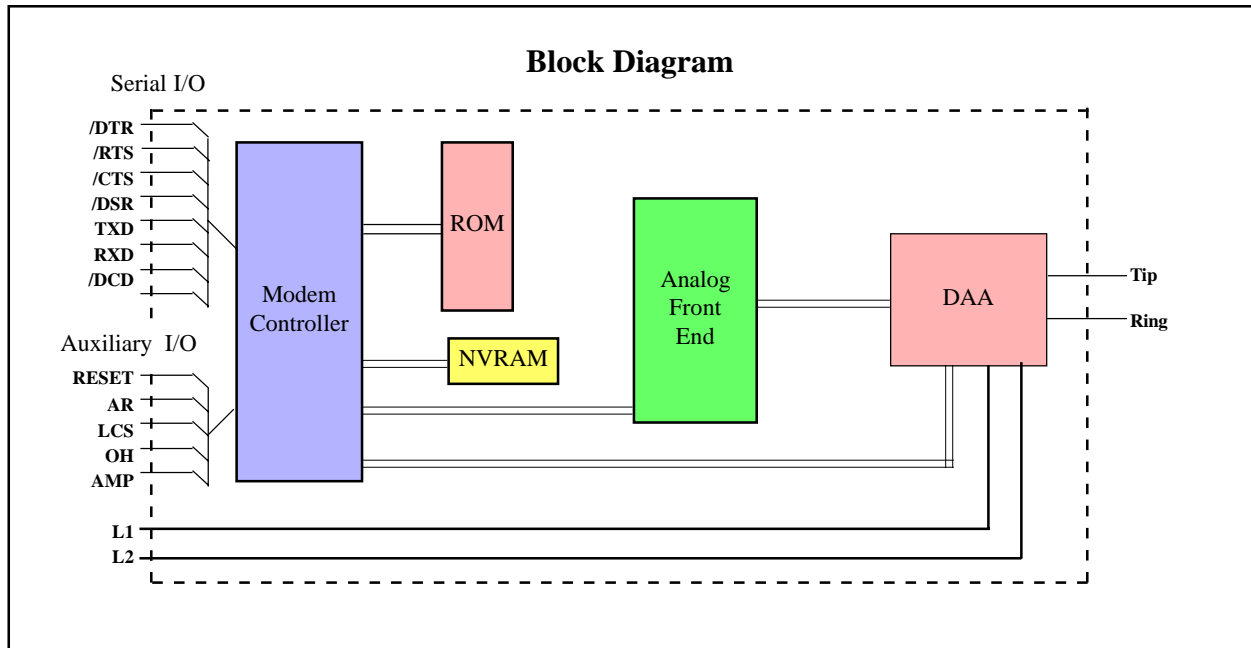

XE1414C Mechanical Specifications

PIN	INCHES		METRIC(MM)	
	MIN	MAX	MIN	MAX
A	2.74	2.760	69.60	70.10
B	1.370	1.390	34.80	35.31
C	0.420	0.430	10.67	10.92
D	1.190	1.210	30.23	30.73
E	1.890	1.910	48.01	48.51
F	0.125	0.200	3.18	5.08
G	0.080	0.100	2.03	2.54
H	0.415	0.435	10.54	11.05
J	0.090	0.110	2.29	2.79
K	0.020	0.025	0.51	0.64

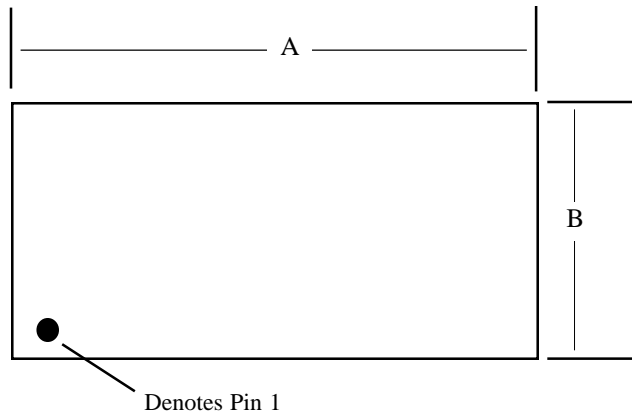

Pins = 0.025 inch square pin; All pins tin-plated

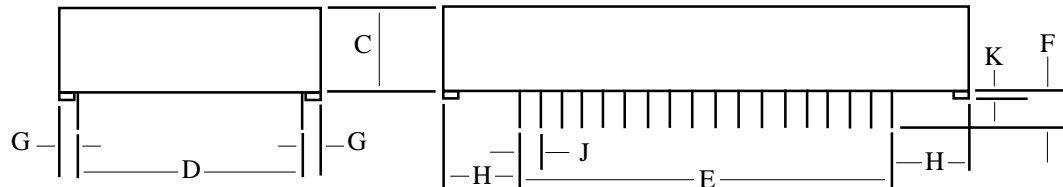

XE1414C PIN CONFIGURATION

NC	□ 1	40	□ VCC
AR	□ 2	39	□ /DSR
RXD	□ 3	38	□ /DCD
NC	□ 4	37	□ NC
NC	□ 5	36	□ RESET
NC	□ 6	35	□ NC
NC	□ 7	34	□ NC
NC	□ 8	33	□ NC
/DTR	□ 9	32	□ NC
LCS	□ 10	31	□ NC
/CTS	□ 11	30	□ OH
NC	□ 12	29	□ NC
TXD	□ 13	28	□ L2
/RTS	□ 14	27	□ L1
NC	□ 15		
/RI	□ 16		
TIP	□ 18		
		22	□ AMP
RING	□ 20	21	□ GND

XE1414C PIN DESCRIPTIONS

PIN	NAME	DESCRIPTION
1	NC	No Internal Connection
2	AR	Auxiliary Data/Voice Relay, Active High Output, TTL/CMOS. The AR signal goes high when ever the modem is in the on-hook state. It can be connected to an external relay to switch control of the telephone line between the modem and an auxiliary handset when.
3	RXD	Received Data, Output, TTL. Serial data output to the host. A logic "High" on RXD represents a "mark" and a logic "Low" represents a "space".
4-8	NC	No Internal Connection
9	\DTR	Data Terminal Ready, Input, active Low, TTL. The "AT&D" command sets the function of \DTR. The default, AT&D2, requires the host to assert \DTR to permit a modem link. The modem drops the call in progress if \DTR is revoked and will not connect until \DTR is reasserted.
10	LCS	Loop Current Sense, input, active High, TTL/CMOS. LCS provides an input to the modem from an external loop current sensor. The Loop Current Sensor may be required for some applications in which the modem shares a telephone line with a telephone handset.
11	\CTS	Clear to Send, Output, active Low, TTL/CMOS. \CTS provides the flow control output from the modem when hardware flow control is selected. The modem revokes \CTS when the modem's input buffer is full. The modem reasserts \CTS when the buffer can accept more data without a buffer overflow.
12	NC	No Internal Connection
13	TXD	Transmit Data, Input, TTL. Serial data input from the host. A logic "High" represents a "mark" and a Low represents a "space", TTL.
14	\RTS	Request to Send, input, active Low, TTL. The XE1414C uses \RTS for hardware flow control. When \RTS is revoked; hardware flow control is activated, and the modem will not place data on RXD.
15	NC	No Internal Connection
16	\RI	Ring Indicator, Output, active Low, TTL. When low indicates the modem is receiving a ring signal.
18	TIP	Tip connection to the phone line (RJ11 pin 3) from the internal DAA. The XE1414C is not sensitive to the battery voltage polarity across Tip and Ring.
20	RING	Ring connection to the phone line (RJ11 pin 4) from the internal DAA.
21	GND	Ground (0 volts)
22	AMP	Audio Output function is set by L & M commands and the value in register S22. This output can drive a minimum load of 300 ohms.
27-28	L1, L2	L1 and L2 provide the control the performance of the loop current holding circuit. When a jumper is applied between L1 and L2, the CTR21 current limiting circuit is active and DC loop current is limited to 60 milliamps. When no jumper is provided, a full 100 milliamps of loop current is supported.
29	N/C	No Internal Connection
30	OH	Off-Hook, Output, active High. OH indicates the modem's hookswitch relay is closed. Hookswitch closure connects the modem to the telephone line.
31-35	N/C	No Internal Connection
36	RESET	Hardware reset pin, Input, active High, TTL. A high on Pin 36 initiates a hardware reset. An external reset is not required or recommended. The Reset pulse must be held a minimum of 100 milliseconds.
37	N/C	No Internal Connection

XE1414C PIN DESCRIPTIONS

PIN	NAME	DESCRIPTION
38	\DCD	Data Carrier Detect, Output Active Low, TTL/CMOS. The &C command sets the function of \DCD. In the default state \DCD activates when a valid carrier is detected.
39	\DSR	Data Set Ready, Output, active Low, TTL/CMOS. &S sets the \DSR function. In the default condition, AT&S0 \DSR is forced true.
40	Vcc	+5 Volts

XE1414C ABSOLUTE MAXIMUM RATINGS

SUPPLY VOLTAGE - Vcc	+6.5 Volts
DC INPUT VOLTAGE	-0.6 Volts to +6.5 Volts
STORAGE TEMPERATURE RANGE	-25° C TO +85° C
LEAD TEMPERATURE (Soldering, 2 sec per wave)	260° C
OPERATING TEMPERATURE RANGE ¹	0 TO 70° C

*Exceeding these values may result in permanent damage to the device.

¹ Extended Operating Temperature (-40° to +85° C) available. Order XE1414C-ITR

XE1414C ELECTRICAL SPECIFICATIONS

Parameter	Min	Typ	Max	Units	Comments
VCC	4.75		5.25	Volts	
ICC	140	160	180	ma	On Line
		40		ma	Sleep Mode
Ring Voltage Detected	38		150	RMS	Type B Ringer
Ring Frequency Detected	15.3		68	Hz	Type B Ringer
Telephone Loop Current	20		100	ma	Off-Hook
Data Transmit level	-11.0	-10.0	-9.0	dBm	
DTMF Transmit Level		-2.5	0	dBm	Avg over 3 second interval

XE1414C Typical Connection Diagram

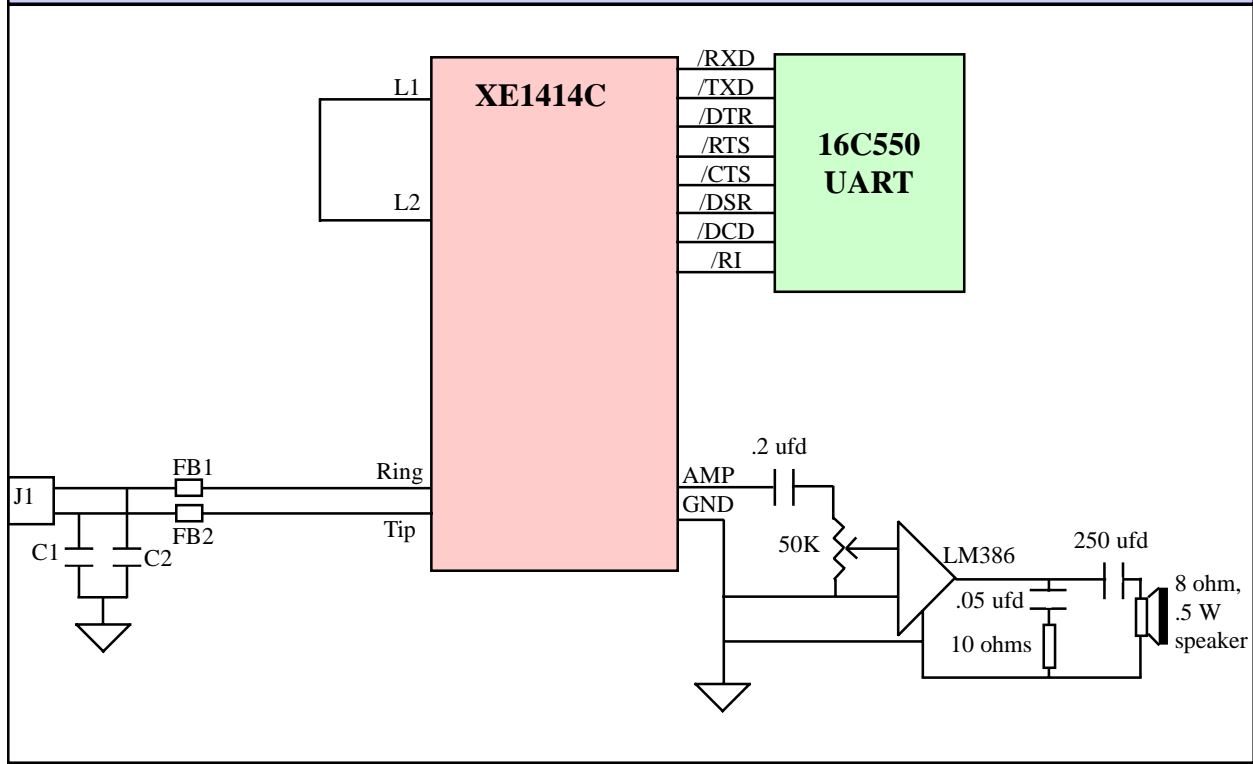

Recommended Parts

<u>Reference Designation</u>	<u>Description</u>	<u>Recommended Part Number</u>
FB1, FB2	Ferrite Beads	TDK ACB2012L-120-X
C1, C2	Capacitors	Panasonic ECKDRS471, 470 pfd, 2600 Volts
J1	RJ11 Jack	Stewart SS6446NF

Notes: 1) RJ11 Pin assignments reflect a 6-pin connector. Tip and Ring are always the center pins of the RJ11 Jack.

- 2) CTR21 requires the modem to be able to dissipate over two Watts in some applications where the integral current limiting circuit is activated. The XE1414C requires a heat sink to be added to dissipate this additional power.

Country Selection

Xecom has designed the XE1414C to the Telephone standards of a wide variety of countries throughout the world. Below is a list of the country standards which Xecom has found the XE1414C to comply. Please contact Xecom if you have questions regarding a country not on this list.

Countries Supported:

<u>COUNTRY</u>	<u>AT COMMAND</u>
Austria	AT+GCI=0A
Belgium	AT+GCI=0F
Denmark	AT+GCI=31
Finland	AT+GCI=3C
France	AT+GCI=3D
Germany	AT+GCI=42
Greece	AT+GCI=46
Holland	AT+GCI=7B
Ireland	AT+GCI=57
Italy	AT+GCI=59
Japan	AT+GCI=00
Korea	AT+GCI=B5
Norway	AT+GCI=82
Portugal	AT+GCI=8B
Singapore	AT+GCI=B5
Spain	AT+GCI=A0
Sweden	AT+GCI=A5
Switzerland	AT+GCI=A6
Taiwan	AT+GCI=B5
United Kingdom	AT+GCI=B4
United States	AT+GCI=B5

NOTE: Country regulations permit Xecom to offer transferrable registration only in the United States, FCC Part 68 only. All other required certifications of systems using the XE1414C are the responsibility of Xecom's customer. Xecom will assist our customers with any of these certifications.

Application Note: XE1414C Leased Line Operation

The XE1414C can support leased line applications. Because newer chipsets do not support automatic leased line operation, the leased line handshake must be controlled by the local host.

Before attempting to establish the leased line connection, one modem must be defined as the originating modem and one as the answering modem. The local host issues an ATD to initiate handshaking on the originating modem and ATA to initiate the handshake on the answering modem. If the leased line connection is broken both local hosts must act to re-initiate the handshake sequence.

No special configuration is required for leased line operation. Any modem configuration for error correction, data compression, and flow control will work. Described below are some configuration options which may be beneficial in your leased line application.

AT&C1 This command sets the operation of the Data Carrier Detect signal. With the &C1 setting Data Carrier Detect becomes active whenever the modem detects a valid carrier signal and becomes inactive when that carrier signal is lost. The local host can monitor Data Carrier Detect to determine whether or not the leased line connection is intact.

AT+MS This command controls the modem handshaking options. It can be used to limit the modem handshake to a particular speed or protocol. The +MS command includes four selectable parameters; modulation, automatic fallback during negotiations, minimum accepted data rate and maximum data rate. Setting the maximum and minimum data rates to the same value will require the modem to connect at only the desired data rate. The format and codes for the +MS command are shown below.

AT+MS modulation, auto negotiation, minimum data rate, maximum data rate<ENTER>

Modulation Type	V21 - V.21(300 BPS)
	V22 - V.22 (1200 BPS)
	V22B - V.22bis (2400 BPS)
	V23 - V.23 (1200 BPS Half Duplex)
	V32 - V.32 (9600 BPS)
	V32B - V.32bis (14,400 BPS)
	B103 - Bell 103 (300 BPS)
	B212 - Bell 212 (1200 BPS)

Auto Negotiation	0 - Automode disabled
	1 - Automode enabled

Minimum Data Rate	300 - 300 BPS
or	1200 - 1200 BPS
Maximum Data Rate	2400 - 2400 BPS
	4800 - 4800 BPS
	7200 - 7200 BPS
	9600 - 9600 BPS
	12000 - 12,000 BPS
	14400 - 14,400 BPS

XE1414C AT COMMANDS

Modes of Operation

The XE1414C uses "AT" commands for modem control and configuration. The XE1414C operates in three modes; Command Mode, Fax Mode and Data Mode. Extensions to the AT command set support fax operation.

Data Mode: The modem enters data mode after establishing a modem link and issues a "CONNECT" result code. In Data Mode the modem modulates all signals presented on Transmit Data, Pin 13, and sends them to the remote modem. The modem demodulates the signal from the remote modem and places it onto Received Data, Pin 3, for the host equipment. When the modem exits data mode, it issues a "NO CARRIER" result code.

Command Mode: The XE1414C enters command mode on application of power, reset, loss of the connection, or receipt of the escape sequence. In command mode the modem accepts commands from the host on Transmit Data. Appropriate result codes are returned on Received Data at the same speed and parity as the commands.

Fax Mode: The modem enters fax mode on receipt of the AT+FCLASS=1 command. Fax commands and responses are issued at 19,200 bits per second; the character format is 8 bits no parity. The modem accepts Class 1 Fax commands only in fax mode. The A/, ATO, AT&T and escape commands are not valid in fax mode.

Commands

The modem is configured and controlled with AT commands. AT commands follow a strict format. The command line is stored in the command buffer and executed upon receipt of a carriage return. Until executed, the command line can be edited with the backspace key.

Command Format - Each command, except A/, begins with the AT prefix. The "A" and "T" may be both upper case or both lower case but cannot be of different cases. The modem uses the prefix to identify the host's speed and parity. The modem determines speed by measuring the width of the incoming bits and parity by comparing the parity bits of the "A" and "T." The modem then returns result codes at the host's speed and parity.

Command Line - A command line may include multiple commands. The modem executes the commands in the sequence they appear in the command line. Spaces, inserted to improve legibility, do not fill space in the command buffer. A carriage return terminates the command line and causes the commands to be executed. Register S3 allows the user to select a character other than a carriage return to terminate the command line.

Command Buffer - The command buffer holds a maximum of 40 characters, including the AT prefix. If it overflows, the modem issues an "ERROR" result code and commands are not executed.

Command Line Editing - A backspace can be used to edit the command line any time before it is executed. The backspace character erases the previous character in the command line. Any character except for the "A" and "T" can be erased. Register S5 allows the user to select a character other than a backspace to edit the command line.

Re-Execute Last Command - The A/ command causes the XE1414C to re-execute the command line stored in the command buffer. This is the only command which does not require the "AT" prefix.

Omitted Parameters - Most commands include a parameter which determines the command function. When the parameter is omitted from the command string, it is assumed to be a 0.

Escape Characters - A three character escape sequence, entered while in data mode, will switch the modem into command mode while remaining on line. The escape character, set by Register S2, is entered 3 times in succession to execute the escape. The default escape sequence is "+++."

Result Codes - The modem issues a result code after each action. Result codes may be provided as full words, numeric codes or may be disabled. Each result code ends with a carriage return when numeric result codes are chosen. When full word result codes are chosen, a Line Feed and Carriage Return precede and follow each result code.

XE1414C AT COMMANDS (continued)

List of Commands

An asterisk indicates the default setting of the command for the XE1414C.

A - Answer Command - ATA forces the modem to immediately go off-hook and begin transmitting the answer tone sequence.

Bn - Select Communications Standard - ATBn selects the modulation scheme used for connections below 2400 bits per second

- n=0 Selects CCITT standards *
- n=1 Selects Bell standards

D - Dial Command - Below are the characters accepted in a dialing command.

0-9, #, * = Dialing Digits

- L = Re-dial last number
- P = Pulse dial
- T = Tone dial

S=n = Dial stored number

- W = Wait for dial tone
- ^ = Toggles state of calling tone
- , = Pause for the duration of S8
- @ = Wait for silence
- ! = Switch hook flash
- ; = Return to the command state

En - Command Echo - ATEn determines whether commands will be echoed back to the host.

- n=0 Do not echo commands
- n=1 Enable command echo*

Hn - Switch Hook Control - ATHn opens and closes the modem's hook switch.

- n=0 Switch hook relay opens
- n=1 The switch hook relay closes

In - Modem Identification - ATIn Identifies the version of the modem.

Ln - Speaker Volume - ATLn sets the amplitude of the modem's audio output.

- n=0 Lowest speaker volume
- n=1 Low speaker volume*
- n=2 Moderate speaker volume
- n=3 High speaker volume

Mn - Speaker Activity - ATMn determines when the modem's audio output is active.

- n=0 Speaker off
- n=1 Speaker on until carrier received*
- n=2 Speaker remains on
- n=3 Speaker off during dialing, on until carrier

On - On Line - ATO n switches the modem from the command mode to the data mode.

- n=0 Return On Line with no retrain*
- n=1 Initiate retrain returning On Line.

Qn - Responses - ATQn determines if the modem will issue responses.

- n=0 Send responses*
- n=1 No Responses

Sr? - Interrogate Register - ATSr? requests the current value in register Sr.

Sr=n - Set Register Value - ATSr=n sets the value of register Sr to n.

Vn - Result Codes - ATVn sets the modem to issue Numeric or Full Word result codes .

- n=0 Numeric Result Codes
- n=1 English Word Result Codes*

Wn - Connect Message Rate - ATWn determines whether the data rate reported in the Connect response is the host data rate, the link data rate or whether both are provide along with the error control and data compression protocols negotiated.

- n=0 Respond "CONNECT XXXX" where XXXX is the DTE Rate*
- n=1 Report line speed, DTE speed and Link protocol
- n=2 Respond "CONNECT XXXX " where XXXX Reports Link speed

Xn - Result Code Set - ATXn selects which set of result codes the modem may send.

- n=0 Result codes 0 to 4
- n=1 Result codes 0 to 5 and 10
- n=2 Result codes 0 to 6 and 10
- n=3 Result codes 0 to 5, 7 and 10
- n=4 Full Result codes*

XE1414C AT COMMANDS (continued)

Zn - Reset - ATZn executes a soft reset to the modem and resets the modem configuration.

- n=0 Reset to user profile 0*
- n=1 reset to user profile 1

&Cn - DCD Operation - AT&Cn determines the operation of the DCD output.

- n=0 DCD is forced active.
- n=1 DCD indicates a valid carrier*

&Dn - DTR - AT&Dn determines how the modem will respond to changes to DTR.

- n=0 DTR is ignored by the modem.
- n=1 Enter command mode if DTR revoked.
- n=2 Disconnect if DTR revoked.*
- n=3 Soft reset when DTR revoked

&Fn - Return to Factory Defaults - AT&Fn returns the modem configuration to one of two factory configurations.

- n=0 Restore configuration 0
- n=1 Restore configuration 1

&Gn - Guard Tone - AT&Gn controls the guard tone produced by the modem

- n=0 Guard Tone Disabled *
- n=1 Guard Tone Disabled
- n=2 1800 Hz Guard Tone

&Kn - Flow Control - AT&Kn selects the flow control method used by the modem.

- n=0 Disabled
- n=3 RTS/CTS *
- n=4 XON/XOFF
- n=5 Transparent XON/XOFF

&Pn - Dial Pulse Make/Break Ratio - AT&Pn determines the specific pulse dialing parameters used by the modem.

- n=0 39/61% @ 10 pps*
- n=1 33/67% @ 10 pps
- n=2 39/61% @ 20 pps
- n=3 33/67% @ 20 pps

&Qn - Line Connection - AT&Qn determines if error control or data buffering are active on the link.

- n=0 Direct mode (no data buffering)
- n=5 Use Error Correction *
- n=6 Normal Mode (Speed buffering)

&Sn - DSR Operation - AT&Sn sets the operation of the DSR signal.

- n=0 DSR always active*
- n=1 DSR in accordance with V.25.

&Tn - Test Modes - AT&T selects modem test modes.

- n=0 Exit test mode
- n=1 Local analog loopback

&Vn - View Configuration Profiles - AT&V permits the user to check on the modem's current configuration.

- n=0 View current active and user profiles *
- n=1 View statistics from last connection

&Wn - Store Active Profile - AT&Wn stores the current modem configuration in NVRAM.

- n=0 Store active profile as profile 0
- n=1 Store active profile as profile 1

&Yn - Recall Stored Profile - AT&Yn sets the stored modem configuration to be used after a hard reset.

- n=0 Recall profile 0 on power-up*
- n=1 Recall profile 1 on power-up

&Zn=x - Store phone number "x" in memory location "n"

%Cn - Data Compression - This command sets the modems data compression negotiations.

- n=0 No Data Compression
- n=1 Enables MNP5 Data Compression
- n=2 Enables V.42bis Data Compression
- n=3 Enables both MNP5 and V.42bis *

%En - Line Quality Monitor/Auto Retrain - AT%En determines if the modem will monitor line quality during a connection and initiate a retrain if quality drops below acceptable levels.

- n=0 Disabled
- n=1 Enabled
- n=2 Line quality, fallback, fall forward *

%L - Read Received Signal Level - AT%L permits the user to read the magnitude of the receive signal in dBm.

%Q - Read Line Signal Quality - AT%Q permits the user to read the EQM value of the received signal.

XE1414C AT COMMANDS (continued)

\Bn - Transmit Break - AT\Bn selects the duration of the break signal sent. Break = n x 100 msec.

\Kn - Break control - AT\Kn determines how the modem will handle a break signal received from the host.

Break received from host in data transfer mode.

- n=0 Enter on-line command mode; do not transmit break
- n=1 Purge buffers, immediately transmit break
- n=2 Same as n=0
- n=3 Immediately send break
- n=4 Same as n=0
- n=5 Send break in sequence with data *

Break received from the host during the on-line command mode.

- n=0 Purge buffers, immediately transmit break
- n=1 Same as n=0
- n=2 Immediately send break
- n=3 Same as n=2
- n=4 Send break in sequence with data
- n=5 same as n=4 *

Break received from modem during a non-error corrected link

- n=0 Purge buffers, Immediately send break to host
- n=1 same as n=0
- n=2 Immediately send break to the host
- n=3 Same as n=2
- n=4 Send break in sequence with data.
- n=5 Same as n=2*

\Nn - Error Control Selection - AT\Nn determines how the modem will handle error control negotiations.

- n=0 Normal mode, no error correction
- n=1 Direct mode, no buffering, no error correction
- n=2 Reliable mode, error correction required
- n=3 V.42 Auto-reliable mode, accept either an error controlled or non-error controlled link*
- n=4 V.42 Reliable mode, LAPM required
- n=5 MNP required

/V<value> - **Single Line Connect Messages** - This command allows users to select single line connect messages in the format shown below.

<DTE Speed> <Modulation> <Protocol> <Compression>
<Line Speed> <Voice & Data>

- n=0 No single Line Connect Messages
- n=1 Issue a complete response in a single line

-Kn - **MNP Extended Services** - AT-Kn determines how the modem handles MNP10.

- n=0 No LAPM to MNP10 conversion
- n=1 LAPM to MNP10 conversion*
- n=2 LAPM to MNP10 conversion no MNP Extended Service during V.42 LAPM answer mode detect.

+GCI=nn - **Country Code** - The AT+GCI command sets the country code to be used by the modem. See the country listing on Page 6 for the appropriate country code for your application. The Default country code is B5, United States.

+MS - **Select Modulation** - AT+MS sets the modulation and data rates to be supported by the modem. The format for the +MS command is shown below.

AT+MS=a, b, c, d, e, f<CR>

a - modulation type

- B103 - Bell 103 (300 BPS)
- B212 - Bell 212A (1200 BPS)
- V21 - V.21 (300 BPS)
- V22 - V.22 (1200 BPS)
- V.22B - V.22bis (1200 or 2400 BPS)
- V23 - V.23 (1200 Tx / 75 RX or 75 Tx / 1200 Rx)
- V32 - V.32 (4800 or 9600 BPS)
- V32B - V.32bis (4800 to 14,400 BPS)

b - Automode Detection

- 0 - Automatic Negotiation Disabled
- 1 - Automatic Negotiation Enabled

c - Minimum Receive Data Rate (300 to 14400 BPS)

d - Maximum Receive Data Rate (300 to 14400 BPS)

e - Minimum Transmit Data Rate (300 to 14400 BPS)

f - Maximum Transmit Data Rate (300 to 14400 BPS)

Default: AT+MS=V32B, 1, 300, 300, 300, 14400

XE1414C Modem Registers

<p>S0 Answer on nth Ring: S0 sets the modem to automatically answer on the nth ring. Setting S0 to 0 disables automatic answer.</p> <p>Range: 0 to 255 Units Rings Default 0</p>	<p>S7 Wait for Carrier after Dialing: S7 determines how long the modem waits for a valid carrier signal after dialing is completed.</p> <p>Range: 1 to 255 Units Seconds Default 50</p>
<p>S1 Ring Count: S1 is a read-only register showing the number of rings detected. If a ring is not detected within 8 seconds, S1 is reset to zero.</p> <p>Range: 0 to 255 Units Rings Default 0</p>	<p>S8 Comma Pause Time: S8 defines the duration of the pause initiated by a comma in the dialing string. The pause is generally used when waiting for a second dial tone.</p> <p>Range: 1 to 255 Units Seconds Default 2</p>
<p>S2 Escape Character: S2 sets the ASCII escape character. Values of 0-127 select valid ASCII escape characters; values from 128 to 255 disable the escape sequence.</p> <p>Range: 0 to 255 Units ASCII Character Default 43 (+)</p>	<p>S9 Reserved:</p>
<p>S3 Carriage Return Character: S3 determines the ASCII character to serve as a carriage return to terminate commands and modem responses.</p> <p>Range: 0 to 127 Units ASCII Character Default 13 (Carriage Return)</p>	<p>S10 Carrier Off Disconnect Delay: S10 selects how long carrier must be lost before the modem disconnects. Note: If the value of S10 is smaller than the value of S9, the modem will not automatically disconnect on loss of carrier.</p> <p>Range: 1 to 255 Units 0.1 Seconds Default 14</p>
<p>S4 Line Feed Character: S4 sets the ASCII character to act as a line feed character in modem responses.</p> <p>Range: 0 to 127 Units ASCII Character Default 10 (Line Feed)</p>	<p>S11 Tone Dialing Speed: S11 sets the duration and spacing of the dialing tones. S11 does not affect the pulse dialing rate.</p> <p>Range: 50 to 255 Units 1 Millisecond Default 95</p>
<p>S5 Back Space Character: S5 defines the ASCII character used as a backspace to edit the command line.</p> <p>Range: 0 to 32 Units ASCII Character Default 8 (Back Space)</p>	<p>S12 Escape Code Guard Timer: S12 sets the escape sequence guard timer. If characters are received before or after the escape sequence, within the guard timer, the modem aborts the escape attempt and remains in data mode.</p> <p>Range: 0 to 255 Units 0.02 Seconds Default 50</p>
<p>S6 Dial Tone Wait Time: S6 determines how long the modem waits for dial tone before dialing begins. The Dial Tone Wait Time cannot be set to less than two seconds.</p> <p>Range: 2 to 255 Units Seconds Default 2</p>	

XE1414C Modem Registers (continued)

<p>S14 General Bit-Mapped Options: S14 reflects the state of several "AT" commands.</p> <p>Bit 0,4,6 Not Used</p> <p>Bit 1 0 = Echo Disabled (ATE0) 1 = Echo Active (ATE1)</p> <p>Bit 2 0 = Send Result Codes (ATQ0) 1 = No Result Codes (ATQ1)</p> <p>Bit 3 0 = Numeric Result Codes (ATV0) 1 = Full Word Result Codes (ATV1)</p> <p>Bit 5 0 = Tone Dialing Selected (T) 1 = Pulse Dialing Selected (P)</p> <p>Bit 7 0 = Answer 1 = Originate</p> <p>S16 Test Status: S16 shows the modem test status.</p> <p>Bit 0 0 = No Local Analog Loopback 1 = Local ALB Active</p> <p>Bit 1-7 Not Used</p> <p>S21 General Bit-Mapped Options: S21 reflects the state of several "AT" commands.</p> <p>Bit 0-1 Not Used</p> <p>Bit 2 Always On</p> <p>Bit 3,4 0 = DTR ignored (&D0) 1 = Enter command mode on DTR off (&D1) 2 = Disconnect on DTR off (&D2) 3 = Reset on DTR off (&D3)</p> <p>Bit 5 0 = DCD always active (&C0) 1 = DCD on with Carrier (&C1)</p> <p>Bit 6 0 = DSR always active (&C0) 1 = DSR on when modem ready (&C1)</p> <p>Bit 7 Not Used</p> <p>S22 General Bit-Mapped Options: S22 reflects the state of several "AT" commands.</p> <p>Bit 0-1 0 = Low speaker volume (ATL0) 1 = Low speaker volume (ATL1) 2 = Moderate speaker volume (ATL2) 3 = High speaker volume (ATL3)</p> <p>Bit 2-3 0 = Speaker off (ATM0) 1 = Speaker off with carrier (ATM1) 2 = Speaker always on (ATM2) 3 = Speaker on during handshake (ATM3)</p> <p>Bit 4-6 0 = Basic Result codes (ATX0) 4 = Connect speed result codes (ATX1) 5 = No Blind Dial (ATX2) 6 = Busy Detection (ATX3) 7 = Full result codes (ATX4)</p> <p>Bit 7 Not Used</p>	<p>S23 General Bit-Mapped Options: S23 reflects the state of several "AT" commands.</p> <p>Bit 0-5 Not used</p> <p>Bit 6-7 0 = No Guard Tone (AT&G0) 1 = No Guard Tone (AT&G1) 2 = 1800 Hz guard tone (AT&G2) 3 = Not Used</p> <p>S24 Sleep Mode Timer: S24 sets the length of time in seconds that the modem must be idle before entering the low power, sleep mode. When set to 0, Sleep Mode is disabled.</p> <p>Range: 0 to 255 Units Seconds Default 0</p> <p>S27 General Bit-Mapped Options: S27 reflects the state of several "AT" commands.</p> <p>Bit 0 1 3 0 0 0 = Normal Mode (AT&Q0) 1 0 1 = Error control enabled (AT&Q5) 0 1 1 = Direct Mode (AT&Q6)</p> <p>Bit 2, 4-5, 7 Not Used</p> <p>Bit 6 0 = CCITT Protocols (ATB0) 1 = Bell Protocols (ATB1)</p> <p>S28 Pulse Dialing Bit-Mapped Options: S28 stores the modem's pulse dialing configuration.</p> <p>Bit 0-2, 5-7 Not Used</p> <p>Bit 3-4 0 = Make/Break ratio 39%/61%; 10 pulses per second (AT&P0) 1 = Make/Break ratio 33%/67%; 10 pulses per second (AT&P1) 2 = Make/Break ratio 39%/61%; 20 pulses per second (AT&P2) 3 = Make/Break ratio 33%/67%; 20 pulses per second (AT&P3)</p> <p>S29 Hook Flash Timer: S29 determines the length for time the modem closes its off-hook relay on receipt of the "!" dial modifier to simulate a switch hook flash.</p> <p>Range: 0 to 255 Units 10 milliseconds Default 70</p>
---	---

XE1414C Modem Registers (continued)

<p>S30 Disconnect on Inactivity Timer: S30 sets the period the modem is idle before it disconnects. A 0 disables the inactivity timer.</p> <p>Range: 0 to 255 Units 10 Seconds Default 0</p>	<p>S40 MNP Bit-Mapped Options: S40 shows the status of the modem's MNP commands, .</p> <p>Bit 0-1 0 = No LAPM/MNP10 conversion (AT-K0) 1 = Enable LAPM/MNP10 conversion (AT-K1) 2 = Enable LAPM to MNP10 conversion except for LAPM answer mode (AT-K1)</p> <p>Bit 2 Not Used</p> <p>Bit 3-5 0 = AT\K0 break handling selected 1 = AT\K1 break handling selected 2 = AT\K2 break handling selected 3 = AT\K3 break handling selected 4 = AT\K4 break handling selected 5 = AT\K5 break handling selected</p> <p>Bit 6-7 Not Used</p>
<p>S31 General Bit-Mapped Options: S31 stores the status of various AT commands.</p> <p>Bit 0 0 = No single-line Connect messages (AT\V0) 1 = Use single-line connect messages (AT\V1)</p> <p>Bit 1 Not Used</p> <p>Bit 2-3 0 = Report host speed (ATW0) 1 = Report all parameters (ATW1) 2 = Report modem speed only (ATW2)</p> <p>Bit 4-7 Not Used</p>	<p>S41 General Bit-Mapped Options: S41 stores the condition of various "AT" commands.</p> <p>Bit 0-1 0 = No Data Compression (AT%C0) 1 = MNP5 Data Compression (AT%C1) 2 = V.42bis Data Compression (AT%C2) 3 = Either MNP5 or V.42bis (AT%C3)</p> <p>Bit 2, 6 0 0 = No Fallback/Forward (AT%E0) 1 0 = Retrain Enabled (AT%E1) 0 0 = Fallback/Forward Enabled (AT%E2)</p> <p>Bit 3-5, 7 Not Used</p>
<p>S36 LAPM Failure: S36 instructs the modem what to do if the error control negotiations fail.</p> <p>Bit 0-2 0 = Modem Disconnects 1 = Establish Direct Connection 2 = Reserved 3 = Establish normal Connection 4 = Disconnect if MNP handshake fails 5 = Establish Direct Connection if MNP handshake fails. 6 = Reserved 7 = Establish Normal Connection if MNP handshake fails.</p> <p>Bit 3-7 Not Used</p>	<p>S46 Data Compression Control: S46 selects whether or not the modem will support data compression.</p> <p>S46=136 No data compression S46=138 Data Compression selected Default 138</p>
<p>S38 Forced Disconnect Timer: S38 sets the delay between receipt of the command to disconnect and the actual opening of the switch hook. If S38 is set to 255 the modem disconnects only after its buffers are empty.</p> <p>Range: 0 to 255 Units 1 Second Default 20</p>	<p>S48 V.42 Negotiations: S48 determines the modem's V.42 negotiation process.</p> <p>S48=0 Proceed with LAPM S48=7 Negotiate per V.42* S48=128 Assume LAPM failure</p>
<p>S39 Flow Control Bit-Mapped Options: S39 shows the modem's flow control status, AT&K.</p> <p>Bit 0-2 0 = Flow Control Disabled 1 = Reserved 2 = Reserved 3 = Hardware Flow Control, RTS/CTS 4 = In-Band Flow Control XON/XOFF 5 = Transparent In-Band Flow Control 6 = Reserved 7 = Reserved</p> <p>Bit 3-7 Not used</p>	

XE1414C Modem Registers (continued)

<p>S86 Call Failure Code: S86 shows why the last "NO CAR-RIER response was issued.</p> <p>S86=0 Normal disconnect S86=3 Call Waiting caused disconnect S86=4 Loss of Carrier S86=5 Error Correction negotiation failure S86=6 No response to feature negotiation S86=7 The other modem was synchronous S86=8 No common framing technique S86=9 No common modem protocol S86=10 Bad response to feature negotiation S86=12 Disconnect initiated by remote modem S86=13 No response after 10 retries S86=14 Protocol violation S86=15 DTR deactivated by host S86=16 Received GSTN clear-down S86=17 Inactivity timeout S86=18 Data Rate not supported S86=19 Long Space Disconnect S86=20 Key abort disconnect S86=21 Clear previous disconnect cause S86=22 No Connection established S86=23 Disconnect after 3 retrains S86=24 Call Waiting tone detected S86=25 Extension pickup detected S86=26 Remote hang-up detected</p>	<p>S95 Extended Result Codes: S95 permits the user to customize the extended result codes.</p> <p>Bit 0 Connect result code shows link speed Bit 1 Add /ARQ to connect response Bit 2 Add /VFC to Carrier response Bit 3 Enable Protocol response Bit 4 Not Used Bit 5 Enable Compression Result Code Bit 6 Not used Bit 7 Not Used</p>
--	---

XE1414C Class 1 Fax Commands

<p>AT+FCLASS? - Service Class Indication</p> <p>0 = Configured as a data modem 1 = Configured for Service Class 1.</p> <p>AT+FCLASS=? - Service Class Capability</p> <p>0 = Configured as a data modem 1 = Configured for Service Class 1.</p> <p>AT+FCLASS=n - Set Service Class</p> <p>0 = Configured as a data modem 1 = Configured for Service Class 1.</p> <p>AT+FAE=n - Data/Fax Auto Answer</p> <p>0 = Answer as a fax modem only 1 = Either a fax or data modem</p> <p>AT+FF - Enhanced Flow Control</p> <p>AT+FRH<mod> - Receive HDLC Data</p> <p>3 V.21 Channel 2, 300 bps 24 V.27ter, 2400 bps 48 V.27ter, 4800 bps 72 V.29, 7200 bps</p>	<p>96 V.29, 9600 bps 97 V.17, 9600 bps 98 V.17 short train, 9600 bps 121 V.17, 12,000 bps 122 V.17 short train, 12,000 bps 145 V.17, 14,400 bps 146 V.17 short train, 14,400 bps</p> <p>AT+FRM<mod> - Receive Fax (see AT+FRH for "mod" values)</p> <p>AT+FRS<time> - Receive Silence</p> <p>AT+FRTn - Receive Test Data</p> <p>AT+FTH<mod> - Transmit HDLC Data (see AT+FRH for "mod" values)</p> <p>AT+FTM<mod> - Transmit Fax (see AT+FRH for "mod" values)</p> <p>AT+FTS<time> - Transmit Silence</p> <p>AT+FTTn - Transmit Test Data</p>
---	---

XE1414C Modem Result Codes

<u>Digits</u>	<u>Verbose</u>	<u>Description</u>	<u>igits</u>	<u>Verbose</u>	<u>Description</u>
0	OK	Successfully executed command line	66	+DR: Alt	MNP5 data compression
1	CONNECT	300 bps connection	67	+DR: V42B	V.42bis data compression
2	RING	Ring signal detected	69	+DR: NONE	No data compression
3	NO CARRIER	Carrier not detected/lost	70	+ER: NONE	No error correction
4	ERROR	Error in command line	77	+ER: LAPM	LAPM error correction
5	CONNECT 1200	1200 bps connection	80	+ER: ALT	MNP error correction
6	NO DIAL TONE	No dial tone detected	81	+ER: ALT CELLULAR	MNP10 error correction
7	BUSY	Busy signal detected	84	CONNECT 33600	33,600 bps Connection
8	NO ANSWER	5 second silence not detected	91	CONNECT 31200	31,200 bps Connection
10	CONNECT 2400	2400 bps Connection	134	+MCR: B103	Bell 103 Connection
11	CONNECT 4800	4800 bps Connection	135	+MCR: B212	Bell 212A Connection
12	CONNECT 9600	9600 bps Connection	136	+MCR: V21	V.21 Connection
13	CONNECT 7200	7200 bps Connection	137	+MCR: V22	V.22 Connection
14	CONNECT 12000	12,000 bps Connection	138	+MCR: V22B	V.22bis Connection
15	CONNECT 14400	14,400 bps Connection	139	+MCR: V23	V.23 Connection
16	CONNECT 19200	19,200 bps Connection	140	+MCR: V32	V.32 Connection
17	CONNECT 38400	38,400 bps Connection	141	+MCR: V32B	V.32bis Connection
18	CONNECT 57600	57,600 bps Connection	+F4	+FCERROR	Fax carrier error
19	CONNECT 115200	115200 bps Connection			
22	CONNECT 75TX/1200RX	.23 originate connection			
23	CONNECT 1200TX/75RX	V.23 answer connection			
33	FAX	Fax connection			
35	DATA	Data connection in Fax mode			
40	+MRR: 300	300 bps carrier received			
44	+MRR: 1200/75	V.23 reverse channel carrier received			
45	+MRR: 75/1200	V.23 forward channel carrier received			
46	+MRR: 1200	1200 bps carrier received			
47	+MRR: 2400	2400 bps carrier received			
48	+MRR: 4800	4800 bps carrier received			
49	+MRR: 7200	7200 bps carrier received			
50	+MRR: 9600	9600 bps carrier received			
51	+MRR: 12000	12,000 bps carrier received			
52	+MRR: 14400	14,400 bps carrier received			

XE1414C FCC Registration

All equipment connected to the public telephone network in the United States must have FCC Part 68 Registration. Part 68 registration certifies that the device will not cause harm to the telephone network. The XE1414C provides a user transferable FCC Registration. This permits XE1414C customers to use our FCC registration number without submitting their systems for additional testing. Call Xecom technical support at 408-945-6640 with any questions on whether your system qualifies to use Xecom's FCC Registration Number.

In your operating instructions you must provide certain information to the end user of the modem. The instructions should include most of the instructions shown below. Only the information regarding the mounting of the device in the final assembly should be omitted.

FCC Instructions:

This product complies with Part 68 of the FCC Rules and Regulations. On each device shipped, there is a label which contains, among other information, the FCC Registration Number and Ringer Equivalence Number (REN) for this product. You must, upon request, provide this information to your telephone company.

The mounting of this device in the final assembly must be made in such a manner as to preserve the high voltage protection between the TIP/RING Connection and the rest of the system. Typically, this may be accomplished by maintaining a minimum spacing .100 mils between the TIP/RING Traces to the RJ-11C Jack and low voltage portion of the system. No additional circuitry may be attached between TIP/RING and the telephone line connection, unless specifically allowed in the rules.

The REN is useful to determine the quantity of devices you may connect to a telephone line and still have all of these devices ring when the number is called. In most, but not all areas, the sum of the RENs of all devices connected to one line should not exceed five (5.0). To be certain of the number of devices you may connect to the line, as determined by the REN, you should contact the local telephone company to determine the maximum REN for your calling area.

If your system causes harm to the telephone network, the telephone company may discontinue service temporarily. If possible, they will notify you in advance. If advance notification is not practical, you will be notified as soon as possible.

Your telephone company may make changes in its facilities, equipment, operations or procedures that could affect proper functioning of your equipment. If they do, you will be notified in advance to give you an opportunity to maintain uninterrupted telephone service.

If you experience trouble with this device, please contact XECOM at (408) 945-6640 for assistance. The telephone company may ask you to disconnect this device from the network until the problem has been corrected or until you are sure that the device is not malfunctioning.

The device may not be used on coin service lines provided by the telephone company (this does not apply to private coin telephone applications which use standard telephone lines). Connection to party lines is subject to state tariffs.

FCC Labels:

FCC rules also require a label which is visible from the outside of the equipment. The label should display Xecom's name as holder of the FCC Registration, the FCC Registration Number and Ringer Equivalence of the modem. This is the same information which appears on the top of each XE1414C module.

Terms of Sale

Devices sold by XECOM are covered by the warranty provisions appearing in its Terms of Sale only. XECOM makes no warranty, express, statutory, implied, or by description regarding the information set forth herein, or regarding the freedom of the described devices from patent infringement. XECOM makes no warranty of merchantability or fitness for any purposes. XECOM reserves the right to discontinue production and change specifications and prices at any time and without notice. This product is intended for use in normal commercial applications. Applications requiring extended temperature range, unusual environmental requirements, or high reliability applications, such as military, medical life-support or life-sustaining equipment, are specifically not recommended without additional processing and authorization by XECOM for such application.

Xecom assumes no responsibility for the use of any circuitry other than circuitry embodied in a Xecom product. No other circuits, patents, or licenses are implied.

Life Support Policy

Xecom's products are not authorized for use as Critical Components in Life Support Devices or Systems.

Life Support Devices or Systems are devices or systems which, (a) are intended for surgical implant into the body, or (b) support or sustain life, and whose failure to perform, when properly used in accordance with instructions provided in the labeling, can be reasonably expected to result in significant injury to the user.

A **Critical Component** is any component of a life support device or system whose failure to perform can be reasonably expected to cause failure of the life support device or system, or to affect its safety or effectiveness.

Copyright, Xecom © 2002

While Xecom, Inc. has made every effort to ensure that the information presented here is accurate, Xecom will not be liable for any damages arising from errors or omission of fact. Xecom reserves the right to modify specifications and/or prices without notice. Product mentioned herein are used for identification purposes only and may be trademarks and/or registered trademarks of their respective companies.



Xecom Incorporated
374 Turquoise Street, Milpitas, CA 95035
Ph:408-945-6640 Fax:408-942-1346