

**Compact 33.6 KBPS Modem Module for Embedded Applications**

**Description**

Xecom's XE3314L is a complete, 33.6 Kbps modem in a single component. The XE3314L can be used in throughout North America and Japan. It includes user transferable FCC Part 68 Registration.

The XE3314L is a complete modem including the DAA. XE3314L users do not need to add RAM, ROM, Crystals, low distortion transformer, or switches to complete the modem design. The user only needs to provide the TTL level, serial interface and the telephone line connection.

The XE3314L is a full-featured modem. The XE3314L supports data compression, error correction and fax transfer. The XE3314L also includes NVRAM for permanent storage of the modem configuration.

The XE3314L is pin compatible with Xecom's XE1414L, and XE5614L modems. This family of modems permits a simple upgrade path from 14,400 bps to 56,000 bps.

**Features**

- \* User Transferrable FCC Part 68 Registration
- \* Small Size: 2.75 inches by 1.38 inches by 0.42 inches;
- \* Modem Protocols for data transfer from 33.6 KBPS down to 300 BPS: V.34bis, V.34, V.32bis, V.32, V.22bis, V.22, V.21, Bell 212A and 103;
- \* Modem Control and Configuration via standard AT Commands
- \* Fax Protocols: V.17, V.29, V.27ter, and V.21 channel 2
- \* Error Correction; V.42, MNP2-4 and MNP10
- \* Data Compression; V.42bis and MNP5 provides a maximum effective data rate of 133,400 bps.
- \* Non-Volatile Memory for storing telephone numbers and modem configuration.
- \* Standard operating temperature range 0C to 70C. Extended operating temperature range of -40C to +85C is available.

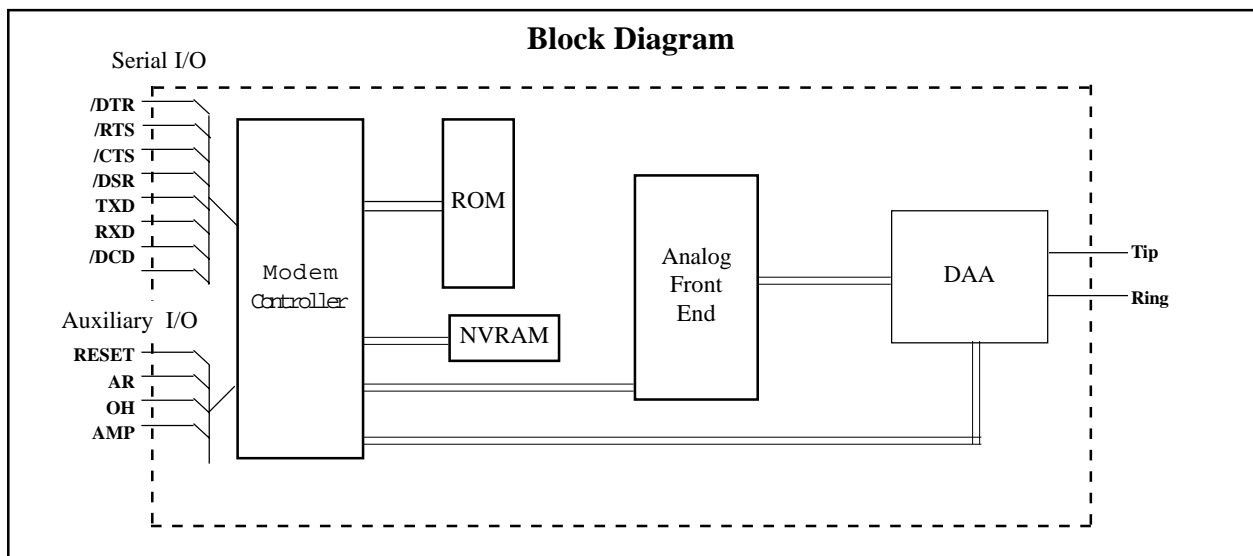

## XE3314L Mechanical Specifications

PIN	INCHES		METRIC(MM)	
	MIN	MAX	MIN	MAX
A	2.74	2.760	69.60	70.10
B	1.370	1.390	34.80	35.31
C	0.420	0.430	10.67	10.92
D	1.190	1.210	30.23	30.73
E	1.890	1.910	48.01	48.51
F	0.125	0.200	3.18	5.08
G	0.080	0.100	2.03	2.54
H	0.415	0.435	10.54	11.05
J	0.090	0.110	2.29	2.79
K	0.020	0.025	0.51	0.64

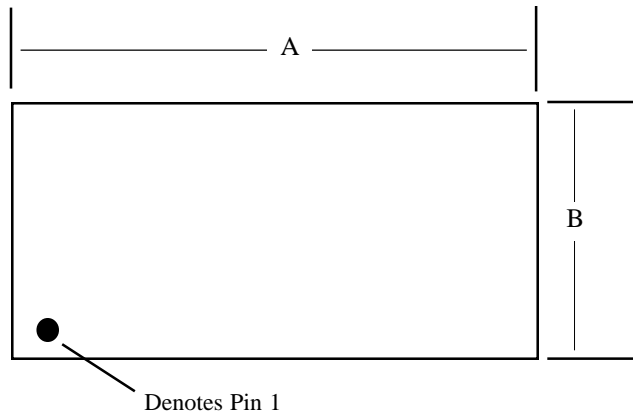

Pins = 0.025 inch square pin; All pins tin-plated

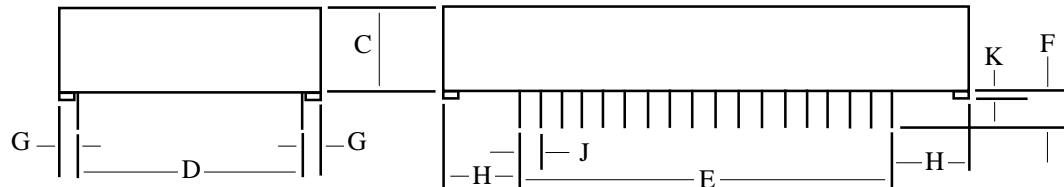

## XE3314L PIN CONFIGURATION

NC	□ 1	40	□ VCC
AR	□ 2	39	□ /DSR
RXD	□ 3	38	□ /DCD
NC	□ 4	37	□ NC
NC	□ 5	36	□ RESET
NC	□ 6	35	□ NC
NC	□ 7	34	□ NC
NC	□ 8	33	□ NC
/DTR	□ 9	32	□ NC
NC	□ 10	31	□ NC
/CTS	□ 11	30	□ OH
NC	□ 12	29	□ NC
TXD	□ 13	28	□ NC
/RTS	□ 14	27	□ NC
NC	□ 15		
/RI	□ 16		
TIP	□ 18		
		22	□ AMP
RING	□ 20	21	□ GND

## XE3314L PIN DESCRIPTIONS

PIN	NAME	DESCRIPTION
1	NC	No Internal Connection
2	AR	Auxiliary Data/Voice Relay, Active High Output, TTL/CMOS. The AR signal goes high when ever the modem is in the on-hook state. It can be connected to an external relay to switch control of the telephone line between the modem and an auxiliary handset when.
3	RXD	Received Data, Output, TTL. Serial data output to the host. A logic "High" on RXD represents a "mark" and a logic "Low" represents a "space".
4-8	NC	No Internal Connection
9	\DTR	Data Terminal Ready, Input, active Low, TTL. The "AT&D" command sets the function of \DTR. The default, AT&D2, requires the host to assert \DTR to permit a modem link. The modem drops the call in progress if \DTR is revoked and will not connect until \DTR is reasserted.
10	NC	No Internal Connection
11	\CTS	Clear to Send, Output, active Low, TTL/CMOS. \CTS provides the flow control output from the modem when hardware flow control is selected. The modem revokes \CTS when the modem's input buffer is full. The modem reasserts \CTS when the buffer can accept more data without a buffer overflow.
12	NC	No Internal Connection
13	TXD	Transmit Data, Input, TTL. Serial data input from the host. A logic "High" represents a "mark" and a Low represents a "space", TTL.
14	\RTS	Request to Send, input, active Low, TTL. The XE3314L uses \RTS for hardware flow control. When \RTS is revoked; hardware flow control is enabled, and the modem will not place data on RXD.
15	NC	No Internal Connection
16	\RI	Ring Indicator, Output, active Low, TTL. When low indicates the modem is receiving a ring signal.
18	TIP	Tip connection to the phone line (RJ11 pin 3) from the internal DAA. The XE3314L is not sensitive to the battery voltage polarity across Tip and Ring.
20	RING	Ring connection to the phone line (RJ11 pin 4) from the internal DAA.
21	GND	Ground (0 volts)
22	AMP	Audio Output function is set by L & M commands and the value in register S22. This output can drive a minimum load of 300 ohms.
27-29	N/C	No Internal Connection
30	OH	Off-Hook, Output, active High. OH indicates the modem's hookswitch relay is closed. Hookswitch closure connects the modem to the telephone line. This signal is available only on the XE3314L.
31-35	N/C	No Internal Connection
36	RESET	Hardware reset pin, Input, active High, TTL. A high on Pin 36 initiates a hardware reset. An external reset is not required or recommended. The Reset pulse must be held a minimum of 100 milliseconds.
37	N/C	No Internal Connection
38	\DCD	Data Carrier Detect, Output Active Low, TTL/CMOS. The &C command sets the function of \DCD. In the default state \DCD activates when a valid carrier is detected.
39	\DSR	Data Set Ready, Output, active Low, TTL/CMOS. &S sets the \DSR function. In the default condition, AT&S0, \DSR is forced true.
40	Vcc	+5 Volts

## **XE3314L ABSOLUTE MAXIMUM RATINGS**

SUPPLY VOLTAGE - V <sub>cc</sub>	+6.5 Volts
DC INPUT VOLTAGE	-0.6 Volts to +6.5 Volts
STORAGE TEMPERATURE RANGE	-25° C TO +85° C
LEAD TEMPERATURE (Soldering, 2 sec per wave)	260° C
OPERATING TEMPERATURE RANGE	0 TO 70° C

\*Exceeding these values may result in permanent damage to the device.

## **XE3314L ELECTRICAL SPECIFICATIONS**

<b>Parameter</b>	<b>Min</b>	<b>Typ</b>	<b>Max</b>	<b>Units</b>	<b>Comments</b>
VCC	4.75		5.25	Volts	
ICC	130	140	160	ma	On Line
		45			Sleep Mode
Ring Voltage Detected	38		150	RMS	Type B Ringer
Ring Frequency Detected	15.3		68	Hz	Type B Ringer
Telephone Loop Current	20		100	ma	Off-Hook
Data Transmit level	-12	-10.5	-9.0	dBm	
DTMF Transmit Level		-2.5	0	dBm	Avg over 3 second interval

## XE3314L Typical Connection Diagram

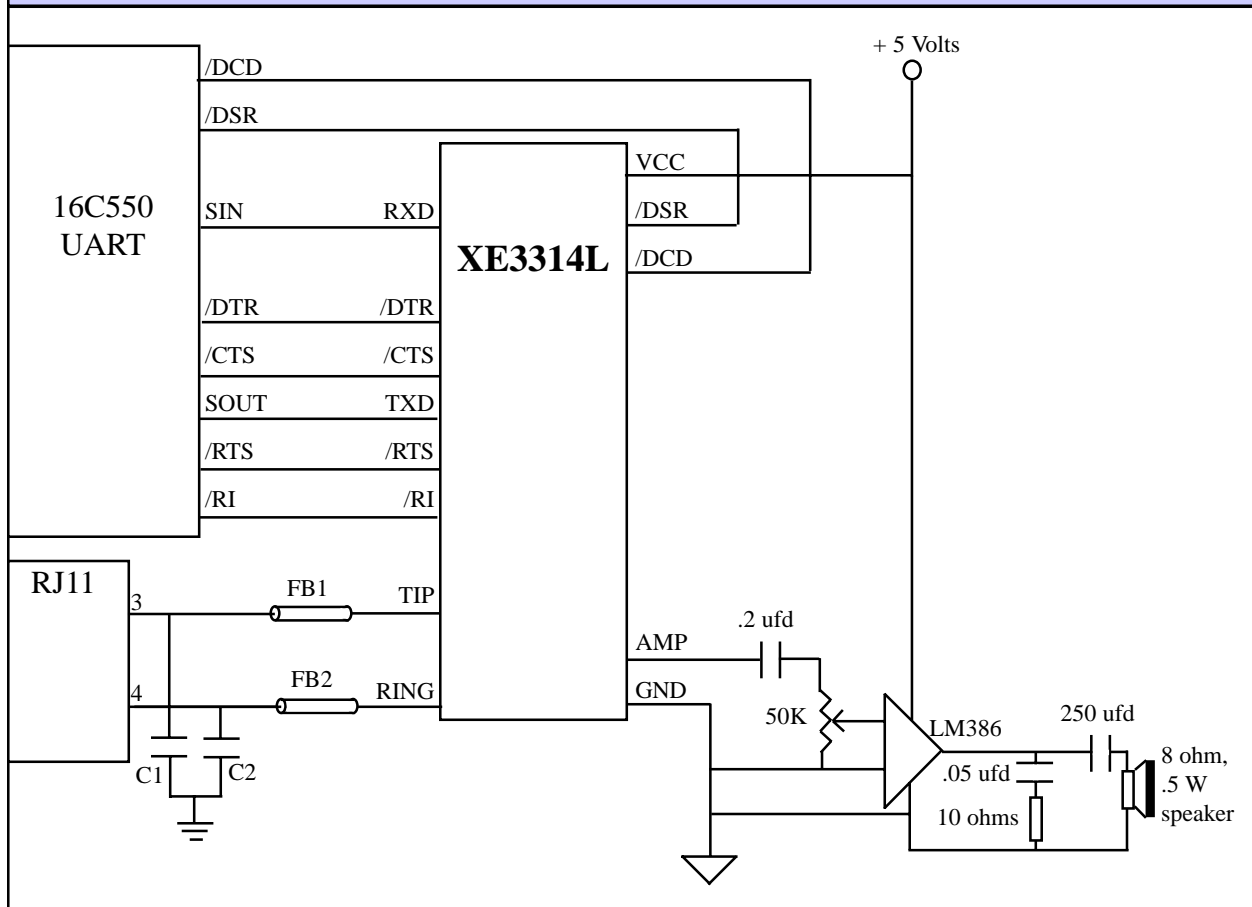

Note: RJ11 Pin assignments reflect a 6-pin connector. Tip and Ring are always the center pins of the RJ11 Jack.

### Recommended Parts

<u>Reference Designation</u>	<u>Description</u>	<u>Recommended Part Number</u>
FB1, FB2	Ferrite Beads	TDK ACB2012L-120-X
C1, C2	470 pfd 2600 VAC Capacitors	Panasonic ECKDR471
J1	RJ11 Jack	Stewart SS6446NF

---

## XE3314L AT COMMANDS

### Modes of Operation

The XE3314L uses "AT" commands for modem control and configuration. The XE3314L operates in three modes; Command Mode, Fax Mode and Data Mode. Extensions to the AT command set support fax operation.

**Data Mode:** The modem enters data mode after establishing a modem link and issues a "CONNECT" result code. In Data Mode the modem modulates all signals presented on Transmit Data, Pin 13, and sends them to the remote modem. The modem demodulates the signal from the remote modem and places it onto Received Data, Pin 3, for the host equipment. When the modem exits data mode, it issues a "NO CARRIER" result code.

**Command Mode:** The XE3314L enters command mode on application of power, reset, loss of the connection, or receipt of the escape sequence. In command mode the modem accepts commands from the host on Transmit Data. Appropriate result codes are returned on Received Data at the same speed and parity as the commands.

**Fax Mode:** The modem enters fax mode on receipt of the AT+FCLASS=1 command. Fax commands and responses are issued at 19,200 bits per second; the character format is 8 bits no parity. The modem accepts Class 1 Fax commands only in fax mode. The A/, ATO, AT&T and escape commands are not valid in fax mode.

### Commands

The modem is configured and controlled with AT commands. AT commands follow a strict format. The command line is stored in the command buffer and executed upon receipt of a carriage return. Until executed, the command line can be edited with the backspace key.

**Command Format** - Each command, except A/, begins with the AT prefix. The "A" and "T" may be both upper case or both lower case but cannot be of different cases. The modem uses the prefix to identify the host's speed and parity. The modem determines speed by measuring the width of the incoming bits and parity by comparing the parity bits of the "A" and "T." The modem then returns result codes at the host's speed and parity.

**Command Line** - A command line may include multiple commands. The modem executes the commands in the sequence they appear in the command line. Spaces, inserted to improve legibility, do not fill space in the command buffer. A carriage return terminates the command line and causes the commands to be executed. Register S3 allows the user to select a character other than a carriage return to terminate the command line.

**Command Buffer** - The command buffer holds a maximum of 40 characters, including the AT prefix. If it overflows, the modem issues an "ERROR" result code and commands are not executed.

**Command Line Editing** - A backspace can be used to edit the command line any time before it is executed. The backspace character erases the previous character in the command line. Any character except for the "A" and "T" can be erased. Register S5 allows the user to select a character other than a backspace to edit the command line.

**Re-Execute Last Command** - The A/ command causes the XE3314L to re-execute the command line stored in the command buffer. This is the only command which does not require the "AT" prefix.

**Omitted Parameters** - Most commands include a parameter which determines the command function. When the parameter is omitted from the command string, it is assumed to be a 0.

**Escape Characters** - A three character escape sequence, entered while in data mode, will switch the modem into command mode while remaining on line. The escape character, set by Register S2, is entered 3 times in succession to execute the escape. The default escape sequence is "+++."

**Result Codes** - The modem issues a result code after each action. Result codes may be provided as full words, numeric codes or may be disabled. Each result code ends with a carriage return when numeric result codes are chosen. When full word result codes are chosen, a Line Feed and Carriage Return precede and follow each

## XE3314L AT COMMANDS (continued)

### List of Commands

An asterisk indicates the default setting of the command for the XE3314L.

**A - Answer Command** - ATA forces the modem to immediately go off-hook and begin transmitting the answer tone sequence.

**Bn - Select Communications Standard** - ATBn selects the modulation scheme used for connections below 2400 bits per second

- n=0 Selects CCITT standards
- n=1 Selects Bell standards\*

**D - Dial Command** - Below are the characters accepted in a dialing command.

0-9, #, \* = Dialing Digits

- L = Re-dial last number
- P = Pulse dial
- T = Tone dial

S=n = Dial stored number

W = Wait for dial tone

^ = Toggles state of calling tone

, = Pause for the duration of S8

@ = Wait for silence

! = Switch hook flash

; = Return to the command state

**En - Command Echo** - ATEn determines whether commands will be echoed back to the host.

- n=0 Do not echo commands
- n=1 Enable command echo\*

**Hn - Switch Hook Control** - ATHn opens and closes the modem's hook switch.

- n=0 Switch hook relay opens
- n=1 The switch hook relay closes

**In - Modem Identification** - ATIn identifies the modem

**Ln - Speaker Volume** - ATLn sets the amplitude of the modem's audio output.

- n=0 Lowest speaker volume
- n=1 Low speaker volume\*
- n=2 Moderate speaker volume
- n=3 High speaker volume

**Mn - Speaker Activity** - ATMn determines when the modem's audio output is active.

- n=0 Speaker off
- n=1 Speaker on until carrier received\*
- n=2 Speaker remains on
- n=3 Speaker off during dialing, on until carrier

**On - On Line** - ATOn switches the modem from the command mode to the data mode.

- n=0 Return On Line with no retrain\*
- n=1 Initiate retrain returning On Line.

**Qn - Responses** - ATQn determines if the modem will issue responses.

- n=0 Send responses\*
- n=1 No Responses

**Sr? - Interrogate Register** - ATSr? requests the current value in register Sr.

**Sr=n - Set Register Value** - ATSr=n sets the value of register Sr to n.

**Vn - Result Codes** - ATVn sets the modem to issue Numeric or Full Word result codes .

- n=0 Numeric Result Codes
- n=1 English Word Result Codes\*

**Wn - Connect Message Rate** - ATWn determines whether the data rate reported in the Connect response is the host data rate, the link data rate or whether both are provide along with the error control and data compression protocols negotiated.

- n=0 Send "CONNECT" at DTE Rate\*
- n=1 Report line speed, DTE speed and Link protocol
- n=2 "CONNECT" Reports Link speed

**Xn - Result Code Set** - ATXn selects which set of result codes the modem may send.

- n=0 Result codes 0 to 4
- n=1 Result codes 0 to 5 and 10
- n=2 Result codes 0 to 6 and 10
- n=3 Result codes 0 to 5, 7 and 10
- n=4 Full Result codes\*

**Zn - Reset** - ATZn executes a soft reset to the modem and resets the modem configuration.

- n=0 Reset to user profile 0\*
- n=1 reset to user profile 1

## XE3314L AT COMMANDS (continued)

**&Cn - DCD Operation** - AT&Cn determines the operation of the DCD output.

- n=0 DCD is forced active.
- n=1 DCD indicates a valid carrier\*

**&Dn - DTR** - AT&Dn determines how the modem will respond to changes to DTR.

- n=0 DTR is ignored by the modem.
- n=1 Enter command mode if DTR revoked.
- n=2 Disconnect if DTR revoked.\*
- n=3 Soft reset when DTR revoked

**&Fn - Return to Factory Defaults** - AT&Fn returns the modem configuration to one of two factory configurations.

- n=0 Restore configuration 0\*
- n=1 Restore configuration 1

**&Gn - Guard Tone** - AT&Gn controls the guard tone produced by the modem

- n=0 Guard Tone Disabled\*
- n=1 Guard Tone Disabled
- n=2 1800 Hz Guard Tone

**&Kn - Flow Control** - AT&Kn selects the flow control method used by the modem.

- n=0 Disabled
- n=3 RTS/CTS
- n=4 XON/XOFF
- n=5 Transparent XON/XOFF

**&Pn - Dial Pulse Make/Break Ratio** - AT&Pn determines the specific pulse dialing parameters used by the modem.

- n=0 39/61% @ 10 pps\*
- n=1 33/67% @ 10 pps
- n=2 39/61% @ 20 pps
- n=3 33/67% @ 20 pps

**&Qn - Line Connection** - AT&Qn determines if error control or data buffering are active on the link.

- n=0 Direct mode (no data buffering)\*
- n=5 Use Error Correction
- n=6 Normal Mode (Speed buffering)

**&Sn - DSR Operation** - AT&Sn sets the operation of the DSR signal.

- n=0 DSR always active\*
- n=1 DSR in accordance with V.25.

**&Tn - Test Modes** - AT&T selects modem test mode.

- n=0 Exit test mode
- n=1 Local analog loopback

**&Vn - View Configuration Profiles** - AT&V permits the user to check on the modems current configuration or conditions of the last call

- n=0 View active profile & user profiles \*
- n=1 View statistics on last call

**&Wn - Store Active Profile** - AT&Wn stores the current modem configuration in NVRAM.

- n=0 Store active profile as profile 0\*
- n=1 Store active profile as profile 1

**&Yn - Recall Stored Profile** - AT&Yn sets the stored modem configuration to be used after a hard reset.

- n=0 Recall profile 0 on power-up\*
- n=1 Recall profile 1 on power-up

**&Zn=x - Store telephone number "x" in memory location "n"**

**%En - Line Quality Monitor/Auto Retrain** - AT%En determines if the modem will monitor line quality during a connection and initiate a retrain if quality drops below acceptable levels.

- n=0 Disabled
- n=1 Enabled
- n=2 Line quality, fallback, fall forward

**%L - Read Received Signal Level** - AT%L permits the user to read the magnitude of the receive signal in dBm.

**%Q - Read Line Signal Quality** - AT%Q permits the user to read the EQM value of the received signal.

**\Bn - Transmit Break** - AT\Bn selects the duration of the break signal sent. Break = n x 100 msec.

**\Gn - Modem Port Flow Control**

- n=0 No Modem Port Flow Control
- n=1 XON/XOFF Port Flow Control



## XE3314L AT COMMANDS (continued)

**\Kn** - Break control - AT\Kn determines how the modem will handle a break signal received from the host.

**Break received from host in data transfer mode.**

- n=0 Enter on-line command mode; do not transmit break
- n=1 Purge buffers, immediately transmit break
- n=2 Same as n=0
- n=3 Immediately send break
- n=4 Same as n=0
- n=5 Send break in sequence with data \*

**Break received from the host during the on-line command mode.**

- n=0 Purge buffers, immediately transmit break
- n=1 Same as n=0
- n=2 Immediately send break
- n=3 Same as n=2
- n=4 Send break in sequence with data
- n=5 same as n=4 \*

**Break received from modem during a non-error corrected link**

- n=0 Purge buffers, Immediately send break to host
- n=1 same as n=0
- n=2 Immediately send break to the host
- n=3 Same as n=2
- n=4 Send break in sequence with data.
- n=5 Same as n=2\*

**\Nn** - Error Control Selection - AT\Nn determines how the modem will handle error control negotiations.

- n=0 Normal mode, no error correction
- n=1 Direct mode, no buffering, no error correction
- n=2 Reliable mode, error correction required
- n=3 V.42 Auto-reliable mode, accept either an error controlled or non-error controlled link\*
- n=4 V.42 Reliable mode, LAPM required
- n=5 MNP required

**/V<value>** - Single Line Connect Messages - This command allows users to select single line connect messages in the format shown below.

- <DTE Speed> <Modulation> <Protocol> <Compression>  
<Line Speed> <Voice & Data>
- n=0 No single Line Connect Messages
  - n=1 Issue a complete response in a single line

**-Kn** - MNP Extended Services - AT-Kn determines how the modem handles MNP10.

- n=0 No LAPM to MNP10 conversion
- n=1 LAPM to MNP10 conversion\*
- n=2 LAPM to MNP10 conversion but no MNP Extended Service during V.42 LAPM answer mode detect.

**+MS** - Select Modulation - AT+MS sets the modulation and data rates to be supported by the modem. The format for the +MS command is shown below.

AT+MS=a, b, c, d, e, f<CR>

a - modulation type

- B103 - Bell 103 (300 BPS)
- B212 - Bell 212A (1200 BPS)
- V21 - V.21 (300 BPS)
- V22 - V.22 (1200 BPS)
- V.22B - V.22bis (1200 or 2400 BPS)
- V23 - V.23 (1200 Tx / 75 RX or 75 Tx / 1200 Rx)
- V32 - V.32 (4800 or 9600 BPS)
- V32B - V.32bis (4800 to 14,400 BPS)
- V34 - V.34 (16,800 to 33,600 BPS)

b - Automode Detection

- 0 - Automatic Negotiation Disabled
- 1 - Automatic Negotiation Enabled

c - Minimum Receive Data Rate (300 to 33600 BPS)

d - Maximum Receive Data Rate (300 to 33600 BPS)

e - Minimum Transmit Data Rate (300 to 33600 BPS)

f - Maximum Transmit Data Rate (300 to 33600 BPS)

Default: AT+MS=V34, 1, 300, 300, 300, 33600

## XE3314L Modem Registers

- S0 Answer on nth Ring:** S0 sets the modem to automatically answer on the nth ring. Setting S0 to 0 disables automatic answer.
- Range: 0 to 255  
Units Rings  
Default 0
- S1 Ring Count:** S1 is a read-only register showing the number of rings detected. If a ring is not detected within 8 seconds, S1 is reset to zero.
- Range: 0 to 255  
Units Rings  
Default 0
- S2 Escape Character:** S2 sets the ASCII escape character. Values of 0-127 select valid ASCII escape characters; values from 128 to 255 disable the escape sequence.
- Range: 0 to 255  
Units ASCII Character  
Default 43 (+)
- S3 Carriage Return Character:** S3 determines the ASCII character to serve as a carriage return to terminate commands and modem responses.
- Range: 0 to 127  
Units ASCII Character  
Default 13 (Carriage Return)
- S4 Line Feed Character:** S4 sets the ASCII character to act as a line feed character in modem responses.
- Range: 0 to 127  
Units ASCII Character  
Default 10 (Line Feed)
- S5 Back Space Character:** S5 defines the ASCII character used as a backspace to edit the command line.
- Range: 0 to 32  
Units ASCII Character  
Default 8 (Back Space)
- S6 Dial Tone Wait Time:** S6 determines how long the modem waits for dial tone before dialing begins. The Dial Tone Wait Time cannot be set to less than two seconds.
- Range: 2 to 255  
Units Seconds  
Default 2
- S7 Wait for Carrier after Dialing:** S7 determines how long the modem waits for a valid carrier signal after dialing.
- Range: 1 to 255  
Units Seconds  
Default 50
- S8 Comma Pause Time:** S8 defines the duration of the pause set by a comma in the dialing string. The pause is generally used when waiting for a second dial tone.
- Range: 1 to 255  
Units Seconds  
Default 50
- S9 Reserved**
- S10 Carrier Off Disconnect Delay:** S10 selects how long carrier must be lost before the modem disconnects.
- Range: 1 to 255  
Units 0.1 Seconds  
Default 14
- S11 Tone Dialing Speed:** S11 sets the duration and spacing of the dialing tones. S11 does not affect pulse dialing.
- Range: 50 to 255  
Units 1 Millisecond  
Default 95
- S12 Escape Code Guard Timer:** S12 sets the guard timer for the escape sequence. If characters are received within the guard time, the modem aborts the escape attempt and remains in data mode.
- Range: 0 to 255  
Units 0.02 Seconds  
Default 50
- S14 General Bit-Mapped Options:** S14 reflects the state of several "AT" commands.
- Bit 0,4,6 Not Used
- Bit 1 0 = Echo Disabled (ATE0)  
1 = Echo Active (ATE1)
- Bit 2 0 = Send Result Codes (ATQ0)  
1 = No Result Codes (ATQ1)
- Bit 3 0 = Numeric Result Codes (ATV0)  
1 = Full Word Result Codes (ATV1)
- Bit 5 0 = Tone Dialing Selected (T)  
1 = Pulse Dialing Selected (P)
- Bit 7 0 = Answer  
1 = Originate

## XE3314L Modem Registers (continued)

**S16 Test Status:** S16 shows the modem test status.

- Bit 0 0 = No Local Analog Loopback  
1 = Local ALB Active
- Bit 2 - 7 Not Used

**S21 General Bit-Mapped Options:** S21 reflects the state of several "AT" commands.

- Bit 0-2, 7 Not Used
- Bit 3,4 0 = DTR ignored (&D0)  
1 = Enter command mode on DTR off (&D1)  
2 = Disconnect on DTR off (&D2)  
3 = Reset on DTR off (&D3)
- Bit 5 0 = DCD always active (&C0)  
1 = DCD on with Carrier (&C1)
- Bit 6 0 = DSR always active (&S0)  
1 = DSR on when modem ready (&S1)

**S22 General Bit-Mapped Options:** S22 reflects the state of several "AT" commands.

- Bit 0-1 0 = Low speaker volume (ATL0)  
1 = Low speaker volume (ATL1)  
2 = Moderate speaker volume (ATL2)  
3 = High speaker volume (ATL3)
- Bit 2-3 0 = Speaker off (ATM0)  
1 = Speaker off with carrier (ATM1)  
2 = Speaker always on (ATM2)  
3 = Speaker on during handshake (ATM3)
- Bit 4-6 0 = Basic Result codes (ATX0)  
4 = Connect speed result codes (ATX1)  
5 = No Blind Dial (ATX2)  
6 = Busy Detection (ATX3)  
7 = Full result codes (ATX4)
- Bit 7 Not Used

**S23 General Bit-Mapped Options:** S23 reflects the state of several "AT" commands.

- Bit 0-5 Not Used
- Bit 6-7 0 = No Guard Tone (AT&G0)  
1 = No Guard Tone (AT&G1)  
2 = 1800 Hz guard tone (AT&G2)  
3 = Not Used

**S24 Sleep Mode Timer:** S24 sets the length of time in seconds that the modem must be idle before entering the low power, sleep mode. When S24 is set to 0, sleep mode is disabled.

- Range: 0 to 255
- Units: seconds
- Default: 0

**S27 General Bit-Mapped Options:** S27 reflects the state of several "AT" commands.

- Bit 0 1 3  
0 0 0 = Normal Mode (AT&Q0)  
1 0 1 = Error control enabled (AT&Q5)  
0 1 1 = Direct Mode (AT&Q6)
- Bit 2, 4-5, 7 Not Used
- Bit 6 0 = CCITT Protocols (ATB0)  
1 = Bell Protocols (ATB1)

**S28 Pulse Dialing Bit-Mapped Options:** S28 stores the modem's pulse dialing configuration.

- Bit 0-2, 5-7 Not Used
- Bit 3-4 0 = Make/Break ratio 39%/61%; 10 pulses per second (AT&P0)  
1 = Make/Break ratio 33%/67%; 10 pulses per second (AT&P1)  
2 = Make/Break ratio 39%/61%; 20 pulses per second (AT&P2)  
3 = Make/Break ratio 33%/67%; 20 pulses per second (AT&P3)

**S29 Hook Flash Timer:** S29 determines the length for time the modem closes its off-hook relay on receipt of the "!" dial modifier to simulate a switch hook flash.

- Range: 0 to 255
- Units 10 milliseconds
- Default 70

**S30 Disconnect on Inactivity Timer:** S30 sets the period the modem is idle before it disconnects. A 0 disables the inactivity timer.

- Range: 0 to 255
- Units 10 Seconds
- Default 0

**S31 General Bit-Mapped Options:** S31 stores the status of various AT commands.

- Bit 0 0 = No single-line Connect messages (AT\V0)  
1 = Use single-line connect messages (AT\V1)
- Bit 1, 4-7 Not Used
- Bit 2-3 0 = Report host speed (ATW0)  
1 = Report all parameters (ATW1)  
2 = Report modem speed only (ATW2)

## XE3314L Modem Registers (continued)

**S36 LAPM Failure:** S36 instructs the modem what to do if the error control negotiations fail.

- Bit 0-2 0 = Modem Disconnects  
1 = Establish Direct Connection  
3 = Establish normal Connection  
4 = Disconnect if MNP handshake fails  
5 = Establish Direct Connection if MNP handshake fails.  
7 = Establish Normal Connection if MNP handshake fails.  
Bit 3-7 Not Used

**S38 Forced Disconnect Timer:** S38 sets the delay between receipt of the command to disconnect and the actual opening of the switch hook. If S38 is set to 255 the modem disconnects only after its buffers are empty.

- Range: 0 to 255  
Units 1 Second  
Default 20

**S39 Flow Control Bit-Mapped Options:** S39 shows the modem's flow control status, AT&K.

- Bit 0-2 0 = Flow Control Disabled  
3 = Hardware Flow Control, RTS/CTS  
4 = In-Band Flow Control XON/XOFF  
5 = Transparent In-Band Flow Control  
Bit 3-7 Not use

**S40 MNP Bit-Mapped Options:** S40 shows the status of the modem's MNP commands, .

- Bit 0-1 0 = No LAPM/MNP10 conversion (AT-K0)  
1 = Enable LAPM/MNP10 conversion (AT-K1)  
2 = Enable LAPM to MNP10 conversion except for LAPM answer mode (AT-K1)  
Bit 2 Not Used  
Bit 3-5 0 = AT\K0 break handling selected  
1 = AT\K1 break handling selected  
2 = AT\K2 break handling selected  
3 = AT\K3 break handling selected  
4 = AT\K4 break handling selected  
5 = AT\K5 break handling selected  
Bit 6-7 Not Used

**S41 General Bit-Mapped Options:** S41 stores the condition of various "AT" commands.

- Bit 0-1 0 = No Data Compression (AT%C0)  
1 = MNP5 Data Compression (AT&C1)  
2 = V.42bis Data Compression (AT&C2)  
3 = Either MNP5 or V.42bis (AT&C3)  
Bit 2, 6  
0 0 = No Fallback/Forward (AT%E0)  
1 0 = Retrain Enabled (AT%E1)  
0 0 = Fallback/Forward Enabled (AT%E2)  
Bit 3-5, 7 Not Used

**S46 Data Compression Control:** S46 selects whether or not the modem will support data compression.

- S46=136 No data compression  
S46=138 Data Compression selected  
Default 138

**S48 V.42 Negotiations:** S48 determines the modem's V.42 negotiation process.

- S48=0 Proceed with LAPM  
S48=7 Negotiate per V.42\*  
S48=128 Assume LAPM failure

**S86 Call Failure Code:** S86 shows why the last "NO CARRIER" response was issued.

- S86=0 Normal Disconnect  
S86=3 Call Waiting caused Disconnect  
S86=4 Loss of Carrier  
S86=5 V.42 Negotiation Failure  
S86=6 No response to feature Negotiation  
S86=7 Other modem is Synchronous modem  
S86=8 No common framing technique  
S86=9 Modem Handshake Failure  
S86=10 Bad response to Feature Negotiation  
S86=12 Disconnect Initiated by remote modem  
S86=13 No response after 10 retries  
S86=14 Protocol Violation  
S86=15 Lost DTR  
S86=16 Received GSTN clear-down  
S86=17 Inactivity timeout  
S86=18 Speed not supported  
S86=20 Key abort disconnect  
S86=22 No connection established  
S86=23 Disconnect after 3 retrains  
S86=24 Call Waiting tone detected

## XE3314L Modem Registers (continued)

S95 **Extended Result Codes:** S95 permits the user to customize the extended result codes.

- Bit 0 Connect result code shows link speed
- Bit 1 Add /ARQ to connect response
- Bit 2 Add /VFC to Carrier response
- Bit 3 Enable Protocol response
- Bit 4 Not Used
- Bit 5 Enable Compression Result Code
- Bit 6 Not used
- Bit 7 Not Used

## XE3314L Class 1 Fax Commands

### AT+FCLASS? - Service Class Indication

- 0 = Configured as a data modem
- 1 = Configured for Service Class 1.

### AT+FCLASS=? - Service Class Capability

- 0 = Configured as a data modem
- 1 = Configured for Service Class 1.

### AT+FCLASS=n - Set Service Class

- 0 = Configured as a data modem
- 1 = Configured for Service Class 1.

### AT+FAE=n - Data/Fax Auto Answer

- 0 = Answer as a fax modem only
- 1 = Either a fax or data modem

### AT+FF - Enhanced Flow Control

### AT+FRH<mod> - Receive HDLC Data

- 3 V.21 Channel 2, 300 bps
- 24 V.27ter, 2400 bps
- 48 V.27ter, 4800 bps
- 72 V.29, 7200 bps
- 96 V.29, 9600 bps
- 97 V.17, 9600 bps
- 98 V.17 short train, 9600 bps
- 121 V.17, 12,000 bps
- 122 V.17 short train, 12,000 bps
- 145 V.17, 14,400 bps
- 146 V.17 short train, 14,400 bps

### AT+FRM<mod> - Receive Fax

(see AT+FRH for "mod" values)

### AT+FRS<time> - Receive Silence

### AT+FRTn - Receive Test Data

### AT+FTH<mod> - Transmit HDLC Data

(see AT+FRH for "mod" values)

### AT+FTM<mod> - Transmit Fax

(see AT+FRH for "mod" values)

### AT+FTS<time> - Transmit Silence

### AT+FTTn - Transmit Test Data

## XE3314L Modem Result Codes

<u>Digits</u>	<u>Verbose</u>	<u>Description</u>	<u>Digits</u>	<u>Verbose</u>	<u>Description</u>
0	OK	Successfully executed command line	52	+MRR: 14400	14,400 bps carrier received
1	CONNECT	300 bps connection	53	+MRR: 16800	16,800 bps carrier received
2	RING	Ring signal detected	54	+MRR: 19200	19,200 bps carrier received
3	NO CARRIER	Carrier not detected/lost	55	+MRR: 21600	21,600 bps carrier received
4	ERROR	Error in command line	56	+MRR: 24000	24,000 bps carrier received
5	CONNECT 1200	1200 bps connection	57	+MRR: 26400	26,400 bps carrier received
6	NO DIAL TONE	No dial tone detected	58	+MRR: 28800	28,800 bps carrier received
7	BUSY	Busy signal detected	59	CONNECT 16800	16,800 bps connection
8	NO ANSWER	5 second silence not detected	61	CONNECT 21600	21,600 bps connection
9	CONNECT 600	600 bps connection	62	CONNECT 24000	24,000 bps connection
10	CONNECT 2400	2400 bps Connection	63	CONNECT 26400	26,400 bps connection
11	CONNECT 4800	4800 bps Connection	64	CONNECT 28800	28,800 bps connection
12	CONNECT 9600	9600 bps Connection	66	+DR: Alt	MNP5 data compression
13	CONNECT 7200	7200 bps Connection	67	+DR: V42B	V.42bis data compression
14	CONNECT 12000	12,000 bps Connection	69	+DR: NONE	No data compression
15	CONNECT 14400	14,400 bps Connection	70	+ER: NONE	No error correction
16	CONNECT 19200	19,200 bps Connection	77	+ER: LAPM	LAPM error correction
17	CONNECT 38400	38,400 bps Connection	78	+MRR:31200	31,200 bps carrier received
18	CONNECT 57600	57,600 bps Connection	79	+MRR: 33600	33,600 bps carrier received
19	CONNECT 115200	115200 bps Connection	80	+ER: ALT	MNP error correction
22	CONNECT 75TX/1200RX	.23 originate connection	81	+ER: ALT CELLULAR	MNP10 error correction
23	CONNECT 1200TX/75RX	V.23 answer connection	84	CONNECT 33600	33,600 bps Connection
33	FAX	Fax connection	91	CONNECT 31200	31,200 bps Connection
35	DATA	Data connection in Fax mode	134	+MCR: B103	Bell 103 Connection
40	+MRR: 300	300 bps carrier received	135	+MCR: B212	Bell 212A Connection
44	+MRR: 1200/75	V.23 reverse channel carrier received	136	+MCR: V21	V.21 Connection
45	+MRR: 75/1200	V.23 forward channel carrier received	137	+MCR: V22	V.22 Connection
46	+MRR: 1200	1200 bps carrier received	138	+MCR: V22B	V.22bis Connection
47	+MRR: 2400	2400 bps carrier received	139	+MCR: V23	V.23 Connection
48	+MRR: 4800	4800 bps carrier received	140	+MCR: V32	V.32 Connection
49	+MRR: 7200	7200 bps carrier received	141	+MCR: V32B	V.32bis Connection
50	+MRR: 9600	9600 bps carrier received	142	+MCR: V34	V.34 Connection
51	+MRR: 12000	12,000 bps carrier received	+F4	+FCERROR	Fax carrier error

---

## **XE3314L FCC Registration**

All equipment connected to the public telephone network in the United States must have FCC Part 68 Registration. Part 68 registration certifies that the device will not cause harm to the telephone network. The XE3314L provides a user transferable FCC Registration. This permits XE3314L customers to use our FCC registration number without submitting their systems for additional testing. Call Xecom technical support at 408-945-6640 with any questions on whether your system qualifies to use Xecom's FCC Registration Number.

In your operating instructions you must provide certain information to the end user of the modem. The instructions should include most of the instructions shown below. Only the information regarding the mounting of the device in the final assembly should be omitted.

### **FCC Instructions:**

This product complies with Part 68 of the FCC Rules and Regulations. On each device shipped, there is a label which contains, among other information, the FCC Registration Number and Ringer Equivalence Number (REN) for this product. You must, upon request, provide this information to your telephone company.

The mounting of this device in the final assembly must be made in such a manner as to preserve the high voltage protection between the TIP/RING Connection and the rest of the system. Typically, this may be accomplished by maintaining a minimum spacing .100 mils between the TIP/RING Traces to the RJ-11C Jack and low voltage portion of the system. No additional circuitry may be attached between TIP/RING and the telephone line connection, unless specifically allowed in the rules.

The REN is useful to determine the quantity of devices you may connect to a telephone line and still have all of these devices ring when the number is called. In most, but not all areas, the sum of the RENs of all devices connected to one line should not exceed five (5.0). To be certain of the number of devices you may connect to the line, as determined by the REN, you should contact the local telephone company to determine the maximum REN for your calling area.

If your system causes harm to the telephone network, the telephone company may discontinue service temporarily. If possible, they will notify you in advance. If advance notification is not practical, you will be notified as soon as possible.

Your telephone company may make changes in its facilities, equipment, operations or procedures that could affect proper functioning of your equipment. If they do, you will be notified in advance to give you an opportunity to maintain uninterrupted telephone service.

If you experience trouble with this device, please contact XECOM at (408) 945-6640 for assistance. The telephone company may ask you to disconnect this device from the network until the problem has been corrected or until you are sure that the device is not malfunctioning.

The device may not be used on coin service lines provided by the telephone company (this does not apply to private coin telephone applications which use standard telephone lines). Connection to party lines is subject to state tariffs.

### **FCC Labels:**

FCC rules also require a label which is visible from the outside of the equipment. The label should display Xecom's name as holder of the FCC Registration, the FCC Registration Number and Ringer Equivalence of the modem. This is the same information which appears on the top of each XE3314L module.

## Terms of Sale

Devices sold by XECOM are covered by the warranty provisions appearing in its Terms of Sale only. XECOM makes no warranty, express, statutory, implied, or by description regarding the information set forth herein, or regarding the freedom of the described devices from patent infringement. XECOM makes no warranty of merchantability or fitness for any purposes. XECOM reserves the right to discontinue production and change specifications and prices at any time and without notice. This product is intended for use in normal commercial applications. Applications requiring extended temperature range, unusual environmental requirements, or high reliability applications, such as military, medical life-support or life-sustaining equipment, are specifically not recommended without additional processing and authorization by XECOM for such application.

Xecom assumes no responsibility for the use of any circuitry other than circuitry embodied in a Xecom product. No other circuits, patents, or licenses are implied.

## Life Support Policy

Xecom's products are not authorized for use as Critical Components in Life Support Devices or Systems.

**Life Support Devices or Systems** are devices or systems which, (a) are intended for surgical implant into the body, or (b) support or sustain life, and whose failure to perform, when properly used in accordance with instructions provided in the labeling, can be reasonably expected to result in significant injury to the user.

A **Critical Component** is any component of a life support device or system whose failure to perform can be reasonably expected to cause failure of the life support device or system, or to affect its safety or effectiveness.

Copyright, Xecom © 2000

While Xecom, Inc. has made every effort to ensure that the information presented here is accurate, Xecom will not be liable for any damages arising from errors or omission of fact. Xecom reserves the right to modify specifications and/or prices without notice. Product mentioned herein are used for identification purposes only and may be trademarks and/or registered trademarks of their respective companies.

The logo for Xecom, featuring the word "xecom" in a bold, lowercase, sans-serif font. The "x" is stylized with a horizontal bar through it. A registered trademark symbol (®) is located to the upper right of the "m". The logo is set against a black rectangular background.

**Xecom Incorporated**  
374 Turquoise Street, Milpitas, CA 95035  
Ph:408-945-6640 Fax:408-942-1346