

## Features

- Certified to MIL-PRF-38535 Appendix A QML (Qualified Manufacturer Listing.)
- Also available under the following Standard Microcircuit Drawings (SMD): 5962-94717 and 5962-95617.
- Configuration one-time programmable (OTP) read-only memory designed to store configuration bitstreams of Xilinx FPGA devices
- On-chip address counter, incremented by each rising edge on the clock input
- Simple interface to the FPGA requires only one user I/O pin
- Cascadable for storing longer or multiple bitstreams
- Programmable reset polarity (active High or active Low) for compatibility with different FPGA solutions
- Low-power CMOS EPROM process
- Available in 5V version only
- Programming support by leading programmer manufacturers.
- Design support using the Xilinx Alliance and Foundation series software packages.

## Description

The XC1700D QPRO™ family of configuration PROMs provide an easy-to-use, cost-effective method for storing Xilinx FPGA configuration bitstreams.

When the FPGA is in Master Serial mode, it generates a configuration clock that drives the PROM. A short access time after the rising clock edge, data appears on the PROM DATA output pin that is connected to the FPGA D<sub>IN</sub> pin. The FPGA generates the appropriate number of clock pulses to complete the configuration. Once configured, it disables the PROM. When the FPGA is in Slave Serial mode, the PROM and the FPGA must both be clocked by an incoming signal.

Multiple devices can be concatenated by using the  $\overline{CE}$  output to drive the  $\overline{CE}$  input of the following device. The clock inputs and the DATA outputs of all PROMs in this chain are interconnected. All devices are compatible and can be cascaded with other members of the family.

For device programming, either the Xilinx Alliance™ or the Foundation™ series development systems compile the FPGA design file into a standard HEX format which is then transferred to most commercial PROM programmers.

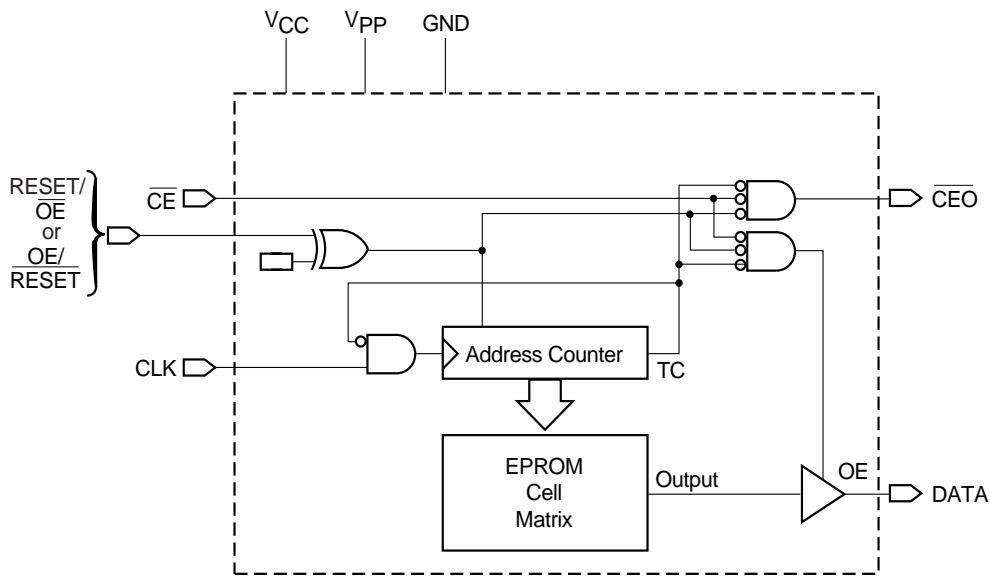

DS027\_01\_021500

Figure 1: Simplified Block Diagram (does not show programming circuit)

## Pin Description

### DATA

Data output, 3-stated when either  $\overline{CE}$  or  $\overline{OE}$  are inactive. During programming, the DATA pin is I/O. Note that  $\overline{OE}$  can be programmed to be either active High or active Low.

### CLK

Each rising edge on the CLK input increments the internal address counter, if both  $\overline{CE}$  and  $\overline{OE}$  are active.

### RESET/ $\overline{OE}$

When High, this input holds the address counter reset and 3-states the DATA output. The polarity of this input pin is programmable as either RESET/ $\overline{OE}$  or OE/RESET. To avoid confusion, this document describes the pin as RESET/ $\overline{OE}$ , although the opposite polarity is possible on all devices. When RESET is active, the address counter is held at zero, and the DATA output is put in a high-impedance state. The polarity of this input is programmable. The default is active High RESET, but the preferred option is active Low RESET, because it can be driven by the FPGAs INIT pin.

The polarity of this pin is controlled in the programmer interface. This input pin is easily inverted using the Xilinx HW-130 programmer software. Third-party programmers have different methods to invert this pin.

### CE

When High, this pin disables the internal address counter, 3-states the DATA output, and forces the device into low- $I_{CC}$  standby mode.

### CEO

Chip Enable output, to be connected to the  $\overline{CE}$  input of the next PROM in the daisy chain. This output is Low when the  $\overline{CE}$  and  $\overline{OE}$  inputs are both active AND the internal address counter has been incremented beyond its Terminal Count (TC) value. In other words: when the PROM has been read,  $\overline{CEO}$  will follow  $\overline{CE}$  as long as  $\overline{OE}$  is active. When  $\overline{OE}$  goes inactive,  $\overline{CEO}$  stays High until the PROM is reset. Note that  $\overline{OE}$  can be programmed to be either active High or active Low.

### $V_{PP}$

Programming voltage. No overshoot above the specified max voltage is permitted on this pin. For normal read oper-

ation, this pin *must* be connected to  $V_{CC}$ . Failure to do so may lead to unpredictable, temperature-dependent operation and severe problems in circuit debugging. Do not leave  $V_{PP}$  floating!

### $V_{CC}$ and GND

$V_{CC}$  is positive supply pin and GND is ground pin.

### PROM Pinouts

Pin Name	8-pin
DATA	1
CLK	2
RESET/ $\overline{OE}$ (OE/RESET)	3
CE	4
GND	5
CEO	6
$V_{PP}$	7
$V_{CC}$	8

### Capacity

Device	Configuration Bits
XC1736D	36,288
XC1765D	65,536
XC17128D	131,072
XC17256D	262,144

### Number of Configuration Bits, Including Header for Xilinx FPGAs and Compatible PROMs

Device	Configuration Bits	PROM
XC3000/A series	14,819 to 94,984	XC1765D to XC17128D
XC4000 series	95,008 to 247,968	XC17128D to XC17256D
XQ4005E	95,008	XC17128D
XQ4010E	178,144	XC17256D
XQ4013E	247,968	XC17256D

## Controlling PROMs

Connecting the FPGA device with the PROM.

- The DATA output(s) of the PROM(s) drives the  $D_{IN}$  input of the lead FPGA device.
- The Master FPGA CCLK output drives the CLK input(s) of the PROM(s).
- The  $\overline{CEO}$  output of a PROM drives the  $\overline{CE}$  input of the next PROM in a daisy chain (if any).
- The  $\overline{RESET/OE}$  input of all PROMs is best driven by the  $\overline{INIT}$  output of the lead FPGA device. This connection assures that the PROM address counter is reset before the start of any (re)configuration, even when a reconfiguration is initiated by a  $V_{CC}$  glitch. Other methods—such as driving  $\overline{RESET/OE}$  from  $\overline{LDC}$  or system reset—assume the PROM internal power-on-reset is always in step with the FPGA's internal power-on-reset. This may not be a safe assumption.
- The PROM  $\overline{CE}$  input can be driven from either the  $\overline{LDC}$  or DONE pins. Using  $\overline{LDC}$  avoids potential contention on the  $D_{IN}$  pin.
- The  $\overline{CE}$  input of the lead (or only) PROM is driven by the DONE output of the lead FPGA device, provided that DONE is not permanently grounded. Otherwise,  $\overline{LDC}$  can be used to drive  $\overline{CE}$ , but must then be unconditionally High during user operation.  $\overline{CE}$  can also be permanently tied Low, but this keeps the DATA output active and causes an unnecessary supply current of 10 mA maximum.

## FPGA Master Serial Mode Summary

The I/O and logic functions of the Configurable Logic Block (CLB) and their associated interconnections are established by a configuration program. The program is loaded either automatically upon power up, or on command, depending on the state of the three FPGA mode pins. In Master Serial mode, the FPGA automatically loads the configuration program from an external memory. The Xilinx PROMs have been designed for compatibility with the Master Serial mode.

Upon power-up or reconfiguration, an FPGA enters the Master Serial mode whenever all three of the FPGA mode-select pins are Low ( $M0=0$ ,  $M1=0$ ,  $M2=0$ ). Data is read from the PROM sequentially on a single data line. Synchronization is provided by the rising edge of the temporary signal CCLK, which is generated during configuration.

Master Serial Mode provides a simple configuration interface. Only a serial data line and two control lines are required to configure an FPGA. Data from the PROM is

read sequentially, accessed via the internal address and bit counters which are incremented on every valid rising edge of CCLK.

If the user-programmable, dual-function  $D_{IN}$  pin on the FPGA is used only for configuration, it must still be held at a defined level during normal operation. Xilinx FPGAs take care of this automatically with an on-chip default pull-up resistor.

## Programming the FPGA With Counters Unchanged Upon Completion

When multiple FPGA-configurations for a single FPGA are stored in a PROM, the  $\overline{OE}$  pin should be tied Low. Upon power-up, the internal address counters are reset and configuration begins with the first program stored in memory. Since the  $\overline{OE}$  pin is held Low, the address counters are left unchanged after configuration is complete. Therefore, to reprogram the FPGA with another program, the DONE line is pulled Low and configuration begins at the last value of the address counters.

This method fails if a user applies  $\overline{RESET}$  during the FPGA configuration process. The FPGA aborts the configuration and then restarts a new configuration, as intended, but the PROM does not reset its address counter, since it never saw a High level on its  $\overline{OE}$  input. The new configuration, therefore, reads the remaining data in the PROM and interprets it as preamble, length count etc. Since the FPGA is the master, it issues the necessary number of CCLK pulses, up to 16 million ( $2^{24}$ ) and DONE goes High. However, the FPGA configuration will be completely wrong, with potential contentions inside the FPGA and on its output pins. This method must, therefore, never be used when there is any chance of external reset during configuration.

## Cascading Configuration PROMs

For multiple FPGAs configured as a daisy-chain, or for future FPGAs requiring larger configuration memories, cascaded PROMs provide additional memory. After the last bit from the first PROM is read, the next clock signal to the PROM asserts its  $\overline{CEO}$  output Low and disables its DATA line. The second PROM recognizes the Low level on its  $\overline{CE}$  input and enables its DATA output. See [Figure 2](#).

After configuration is complete, the address counters of all cascaded PROMs are reset if the FPGA  $\overline{RESET}$  pin goes Low, assuming the PROM reset polarity option has been inverted.

To reprogram the FPGA with another program, the DONE line goes Low and configuration begins where the address counters had stopped. In this case, avoid contention between DATA and the configured I/O use of  $D_{IN}$ .

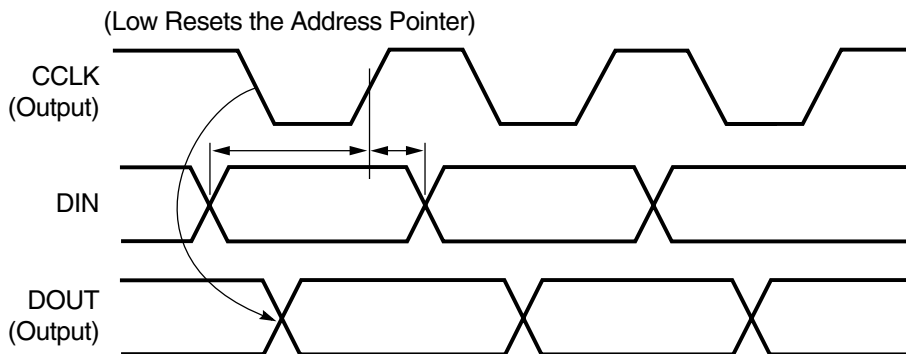
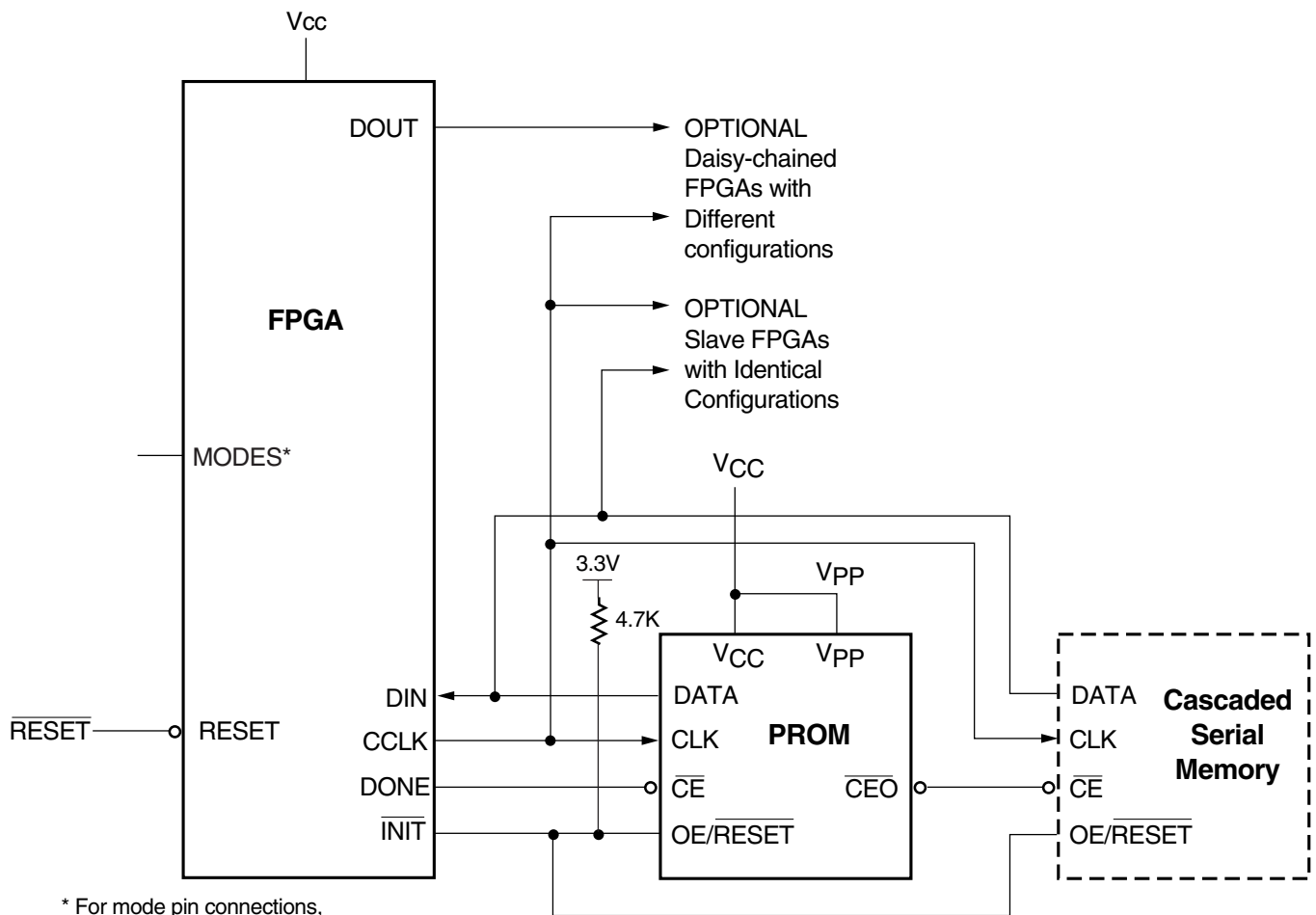

DS027\_02\_052200

**Figure 2: Master Serial Mode.** The one-time-programmable PROM supports automatic loading of configuration programs. Multiple devices can be cascaded to support additional FPGAs. An early DONE inhibits the PROM data output one CCLK cycle before the FPGA I/Os become active.

## Standby Mode

The PROM enters a low-power standby mode whenever  $\overline{CE}$  is asserted High. The output remains in a high impedance state regardless of the state of the  $\overline{OE}$  input.

## Programming

The devices can be programmed on programmers supplied by Xilinx or qualified third-party vendors. The user must ensure that the appropriate programming algorithm and the latest version of the programmer software are used. The wrong choice can permanently damage the device.

Table 1: Truth Table for XC1700 Control Inputs

Control Inputs		Internal Address	Outputs		
RESET	CE		DATA	CEO	I <sub>CC</sub>
Inactive	Low	If address ≤ TC: increment If address > TC: don't change	Active High-Z	High Low	Active reduced
Active	Low	Held reset	High-Z	High	Active
Inactive	High	Not changing	High-Z	High	Standby
Active	High	Held reset	High-Z	High	Standby

**Notes:**

1. The XC1700 RESET input has programmable polarity
2. TC = Terminal Count = highest address value. TC + 1 = address 0.

**Important: Always tie the V<sub>PP</sub> pin to V<sub>CC</sub> in your application. Never leave V<sub>PP</sub> floating.**

## XC1736D, XC1765D, XC17128D and XC17256D

### Absolute Maximum Ratings

Symbol	Description		Units
$V_{CC}$	Supply voltage relative to GND	-0.5 to +7.0	V
$V_{PP}$	Supply voltage relative to GND	-0.5 to +12.5	V
$V_{IN}$	Input voltage relative to GND	-0.5 to $V_{CC} + 0.5$	V
$V_{TS}$	Voltage applied to High-Z output	-0.5 to $V_{CC} + 0.5$	V
$T_{STG}$	Storage temperature (ambient)	-65 to +150	°C
$T_{SOL}$	Maximum soldering temperature (10s @ 1/16 in.)	+260	°C

#### Notes:

- Stresses beyond those listed under Absolute Maximum Ratings may cause permanent damage to the device. These are stress ratings only, and functional operation of the device at these or any other conditions beyond those listed under Operating Conditions is not implied. Exposure to Absolute Maximum Ratings conditions for extended periods of time may affect device reliability.

### Operating Conditions

Symbol	Description		Min	Max	Units
$V_{CC}$	Supply voltage relative to GND ( $T_C = -55^\circ\text{C}$ to $+125^\circ\text{C}$ )	Military	4.50	5.50	V

**Note:** During normal read operation  $V_{PP}$  *must* be connected to  $V_{CC}$

### DC Characteristics Over Operating Condition

Symbol	Description		Min	Max	Units
$V_{IH}$	High-level input voltage		2.0	$V_{CC}$	V
$V_{IL}$	Low-level input voltage		0	0.8	V
$V_{OH}$	High-level output voltage ( $I_{OH} = -4$ mA)	Military	3.7	-	V
$V_{OL}$	Low-level output voltage ( $I_{OL} = +4$ mA)		-	0.4	V
$I_{CCA}$	Supply current, active mode (at maximum frequency)		-	10	mA
$I_{CCS}$	Supply current, standby mode	XC17128D, XC17256D	-	50	$\mu\text{A}$
		XC1736D, XC1765D	-	1.5	mA
$I_L$	Input or output leakage current		-10	10	$\mu\text{A}$
$C_{IN}$	Input capacitance ( $V_{IN} = \text{GND}$ , $f = 1.0$ MHz) sample tested		-	10	pF
$C_{OUT}$	Output capacitance ( $V_{IN} = \text{GND}$ , $f = 1.0$ MHz) sample tested		-	10	pF

AC Characteristics Over Operating Condition<sup>(1,2)</sup>

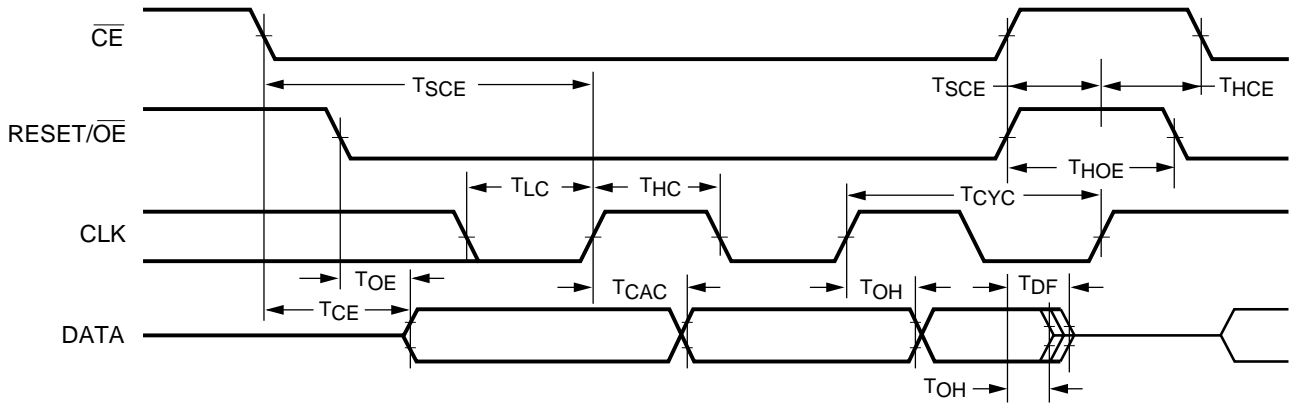

DS027\_03\_021500

Symbol	Description	XC1736D XC1765D		XC17128D XC17256D		Units
		Min	Max	Min	Max	
$T_{OE}$	$\overline{OE}$ to data delay	-	45	-	25	ns
$T_{CE}$	$\overline{CE}$ to data delay	-	60	-	45	ns
$T_{CAC}$	CLK to data delay	-	150	-	50	ns
$T_{OH}$	Data hold from $\overline{CE}$ , $\overline{OE}$ , or CLK <sup>(3)</sup>	0	-	0	-	ns
$T_{DF}$	$\overline{CE}$ or $\overline{OE}$ to data float delay <sup>(3,4)</sup>	-	50	-	50	ns
$T_{CYC}$	Clock periods	200	-	80	-	ns
$T_{LC}$	CLK Low time <sup>(3)</sup>	100	-	20	-	ns
$T_{HC}$	CLK High time <sup>(3)</sup>	100	-	20	-	ns
$T_{SCE}$	$\overline{CE}$ setup time to CLK (to guarantee proper counting)	25	-	20	-	ns
$T_{HCE}$	$\overline{CE}$ hold time to CLK (to guarantee proper counting)	0	-	0	-	ns
$T_{HOE}$	$\overline{OE}$ hold time (guarantees counters are reset)	100	-	20	-	ns

Notes:

1. AC test load = 50 pF
2. All AC parameters are measured with  $V_{IL} = 0.0V$  and  $V_{IH} = 3.0V$ .
3. Guaranteed by design, not tested.
4. Float delays are measured with 5 pF AC loads. Transition is measured at  $\pm 200mV$  from steady state active levels.

**AC Characteristics Over Operating Condition When Cascading<sup>(1,2)</sup>**

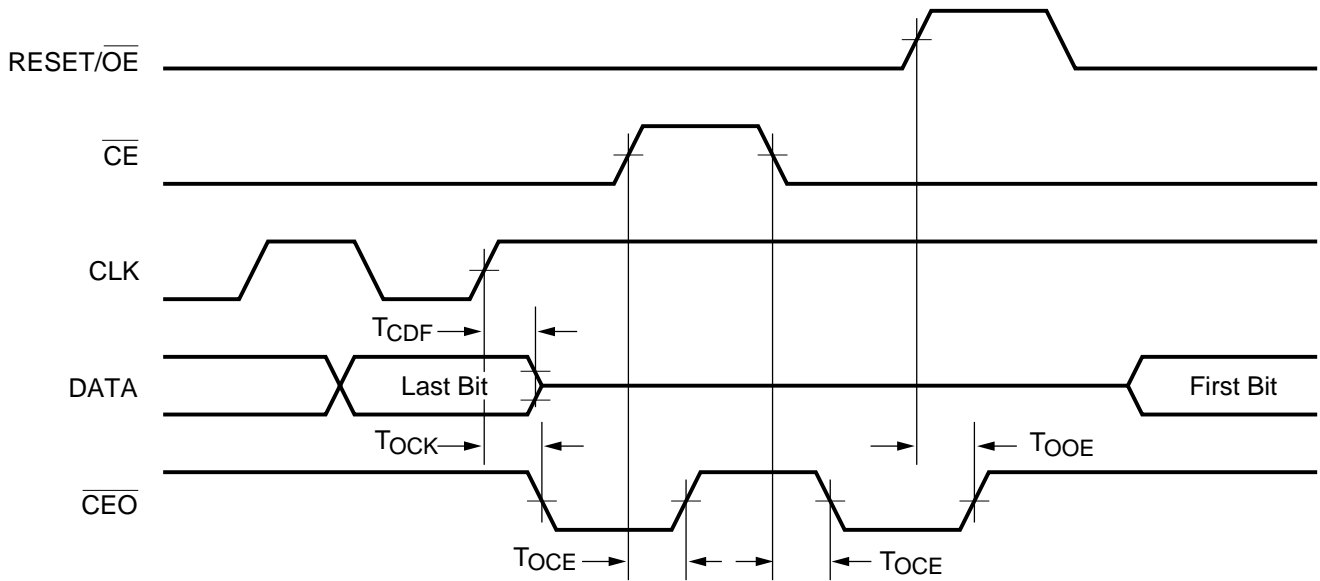

DS027\_04\_021500

Symbol	Description	XC1736D XC1765D		XC17128D XC17256D		Units
		Min	Max	Min	Max	
T <sub>CDF</sub>	CLK to data float delay <sup>(3,4)</sup>	-	50	-	50	ns
T <sub>OCK</sub>	CLK to $\overline{CEO}$ delay <sup>(3)</sup>	-	65	-	30	ns
T <sub>OCE</sub>	CE to $\overline{CEO}$ delay <sup>(3)</sup>	-	45	-	35	ns
T <sub>OOE</sub>	RESET/ $\overline{OE}$ to $\overline{CEO}$ delay <sup>(3)</sup>	-	40	-	30	ns

**Notes:**

1. AC test load = 50 pF
2. All AC parameters are measured with V<sub>IL</sub> = 0.0V and V<sub>IH</sub> = 3.0V.
3. Guaranteed by design, not tested.
4. Float delays are measured with 5 pF AC loads. Transition is measured at ±200mV from steady state active levels.



## Ordering Information

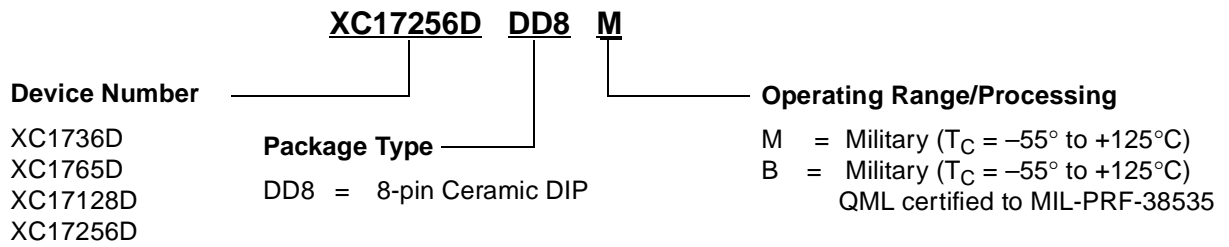

## Valid Ordering Combinations

XC17128DDD8M	XC17256DDD8M	XC1736DDD8M	XC1765DDD8M
	5962-9561701MPA		5962-9471701MPA

## Marking Information

Due to the small size of the PROM package, the complete ordering part number cannot be marked on the package.

The XC prefix is deleted and the package code is simplified. Device marking is as follows.

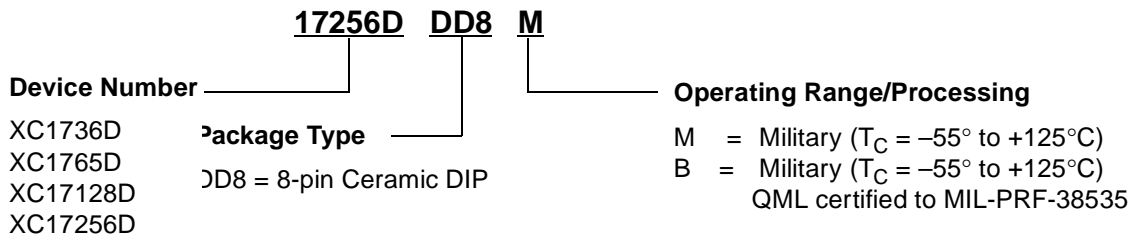

## Revision History

The following table shows the revision history for this document

Date	Version	Revision
02/08/99	2.0	Removed the now obsolete Commercial and Industrial Grade part numbers and design support.
06/01/00	2.1	Updated format and assigned data sheet number (DS070).

