

# YMU759

## MA-2

---

### Outline

YMU759 is a synthesis LSI for portable telephone that is capable of playing high quality music by utilizing FM synthesizer and ADPCM decoder that are included in this device. As a synthesis, YMU759 is equipped with Yamaha's original FM synthesizer, with which the device is capable of simultaneously generating up to 16 voices with different tones. Since the device is capable of generating ADPCM data simultaneously synchronous with the play of the FM synthesizer, various sampled voices can be used as sound effects. Since the play data of YMU759 are interpreted at anytime through FIFO, the length of the data (playing period) is not limited, so the device can flexibly support applications such as incoming call melody distribution service. The hardware sequencer built in this device allows playing of complex music without giving excessive load to the CPU of the portable telephones. Moreover, the registers of the FM synthesizer can be operated directly for real time sound generation, allowing, for example, utilization of various sound effects when using the game software installed in the portable telephone.

YMU759 includes a speaker amplifier with low ripple whose maximum output is 550 mW (SPVDD=3.6V). The device is also equipped with conventional functions including a vibrator and a circuit for controlling LEDs synchronous with music.

For the headphone, it is provided with a stereophonic analog output terminal.

For the purpose of enabling YMU759 to demonstrate its full capabilities, Yamaha proposes to use "SMAF: Synthetic music Mobile Application Format" as a data distribution format that is compatible with multimedia. Since the SMAF takes a structure that sets importance on the synchronization between sound and images, various contents can be written into it including incoming call melody with words that can be used for training karaoke, and commercial channel that combines texts, images and sounds, and others. The hardware sequencer of YMU759 directly interprets and plays blocks relevant to synthesis (playing music and reproducing ADPCM with FM synthesizer) that are included in the data distributed in SMAF.

### Features

#### FM synthesizer functions

##### ■ Tones

FM synthesizer is capable of creating countless tones theoretically.

When synthesizing tones, it is necessary to designate the number of operators to be used for the synthesis. (Refer to "5-7. FM synthesis section" for explanation of operator.)

Increasing the number of operators allows synthesis of tones that are more intricate and closer to those generated by natural musical instruments.

YMU759 supports synthesis of tones of two types including 2-operator tones and 4-operator tones.

Because operator's wave shape can be chosen from eight kinds, the quality of sound improves more remarkably than 2 operator sound of the MA-1 series. (A MA-1 series can choose operator wave shape from two kinds.)

##### ■ Number of voices simultaneously generated

YMU759 is equipped with 32 operators.

The number of voices simultaneously generated varies depending on how many 2-operator tones and 4-operator tones are used.

When only 2-operator tones are used: up to 16 voices can be generated simultaneously.

When only 4-operator tones are used: up to 8 voices can be generated simultaneously.

- Compatible with stereophonic sound generation.
- Volume control
  - Channel volume, master volume, expression, and pan pot control in individual channels
- Sequencer is built in.
- Can interpret Mobile Multimedia Format directly.
- Equipped with four systems of 96 FIFOs for sequence data
- Supports direct access that directly controls FM synthesizer.
- Supports key control with half an octave higher and lower.

#### **ADPCM reproduction function**

- Equipped with ADPCM decoder with 4 bits, 1 channel
- Supports two kinds of sampling frequency, 4 kHz and 8 kHz.
- Sequencer is built in.
- Equipped with 348 byte FIFO for ADPCM data and 32 byte FIFO for sequence data
- Supports direct access that directly controls ADPCM section.

#### **Speaker amplifier and equalizer circuit**

- Output of speaker amplifier: 550 mW when SPVDD=3.6 V, or 400 mW when SPVDD=3.0 V
- Balanced input speaker amplifier provides low ripple
- Built-in equalizer circuit corrects the difference of frequency response among the speakers and forms of bodies.

#### **Interface**

- 4 wire serial interface or 12 wire parallel interface can be selected.

#### **Others**

- PLL is built-in to support master clock input in 2 MHz to 20 MHz range.
- Provided with a circuit for controlling on/off of LEDs and vibrator. These can be operated synchronous with the play data.
- Provided with a stereophonic analog output terminal for headphone
- 16 bit stereophonic D/A converter is built in.
- Supports power down mode. (Typical current: 1  $\mu$ A or less)

#### **Power supply voltage**

The power supply includes two power supply sub-systems, analog power supply devoted to speaker amplifier and power supply for other sections.

The power supply for the speaker amplifier (SPVDD) supplies voltages in the range 2.7 V ~ 4.5 V (Typ 3.6 V), and other power supplies (VDD) voltages in the range 2.7 V ~ 3.3 V (Typ 3.0 V).

**32-pin plastic QFN.**

## Terminal configuration

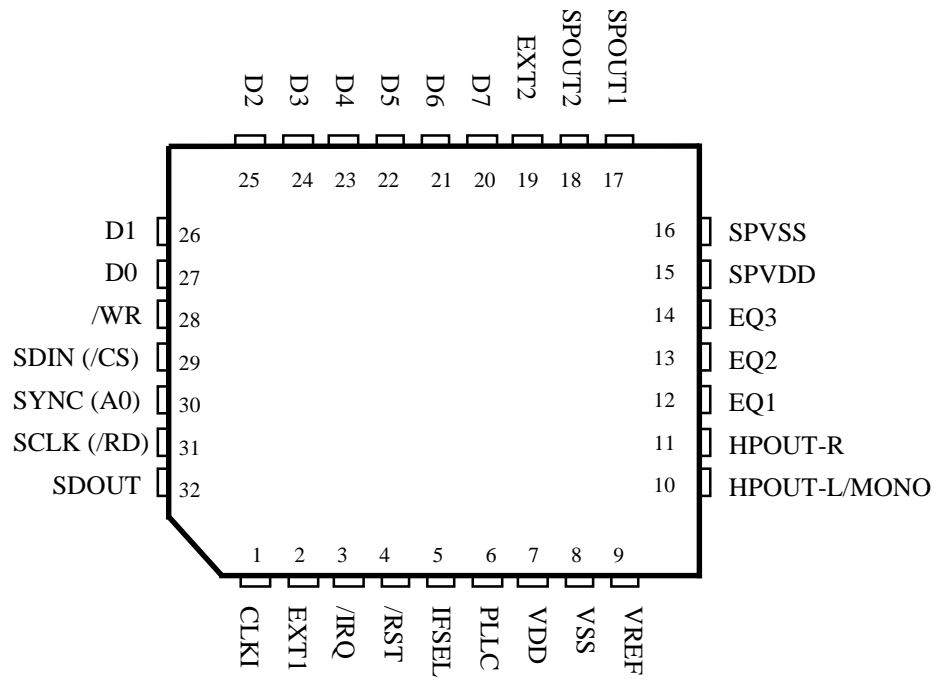

<32pin QFN Top View>

## Terminal functions

No.	Name	I/O	Function
1	CLKI	Ish	Clock input (2~20MHz)
2	EXT1	O	External device control terminal 1 (*)
3	/IRQ	O	Interruption output
4	/RST	Ish	Hardware reset input
5	IFSEL	I	CPU I/F selection L: Serial I/F, H: Parallel I/F
6	PLLC	A	Connection of capacitor for built in PLL Connect the 3.3kΩ resistance and the 1000pF capacitor between this terminal and VSS in series.
7	VDD	-	Digital power supply (Typically +3.0V) Connect 0.1 μF and 4.7 μF capacitors between this terminal and VSS
8	VSS	-	Ground
9	VREF	A	Analog reference voltage. Connect 0.1 μF capacitor between this terminal and VSS
10	HPOUT-L / MONO	A	Headphone L channel output: can be switched to mono through register setting
11	HPOUT-R	A	Headphone R channel output
12	EQ1	A	Equalizer terminal 1
13	EQ2	A	Equalizer terminal 2
14	EQ3	A	Equalizer terminal 3
15	SPVDD	-	Analog power supply (Typically +3.6 V) Connect 0.1 μF and 4.7 μF capacitors between this terminal and SPVSS
16	SPVSS	-	Analog ground for speaker amplifier
17	SPOUT1	A	Speaker terminal 1
18	SPOUT2	A	Speaker terminal 2
19	EXT2	O	External device control terminal 2 (*)
20	D7	I/O	Parallel I/F data bus 7 (*)
21	D6	I/O	Parallel I/F data bus 6 (*)
22	D5	I/O	Parallel I/F data bus 5 (*)
23	D4	I/O	Parallel I/F data bus 4 (To be open when IFSEL=L)
24	D3	I/O	Parallel I/F data bus 3 (To be open when IFSEL=L)
25	D2	I/O	Parallel I/F data bus 2 (To be open when IFSEL=L)
26	D1	I/O	Parallel I/F data bus 1 (To be open when IFSEL=L)
27	D0	I/O	Parallel I/F data bus 0 (To be open when IFSEL=L)
28	/WR	Ish	Parallel I/F write pulse (To be open when IFSEL=L)
29	SDIN (/CS)	Ish	IFSEL= L Serial I/F data input IFSEL= H Parallel I/F chip select input
30	SYNC (A0)	Ish	IFSEL= L Serial I/F data decision signal IFSEL= H Parallel I/F address signal
31	SCLK (/RD)	Ish	IFSEL= L Serial I/F bit clock input IFSEL= H Parallel I/F read pulse
32	SDOUT	OD	Serial I/F data output (Pull up resistance is necessary for the outside)

Comment: Ish= Schmitt input, OD= open drain terminal, A= Analog terminal

(\*) The function changes by setup of the register.

## Block diagram

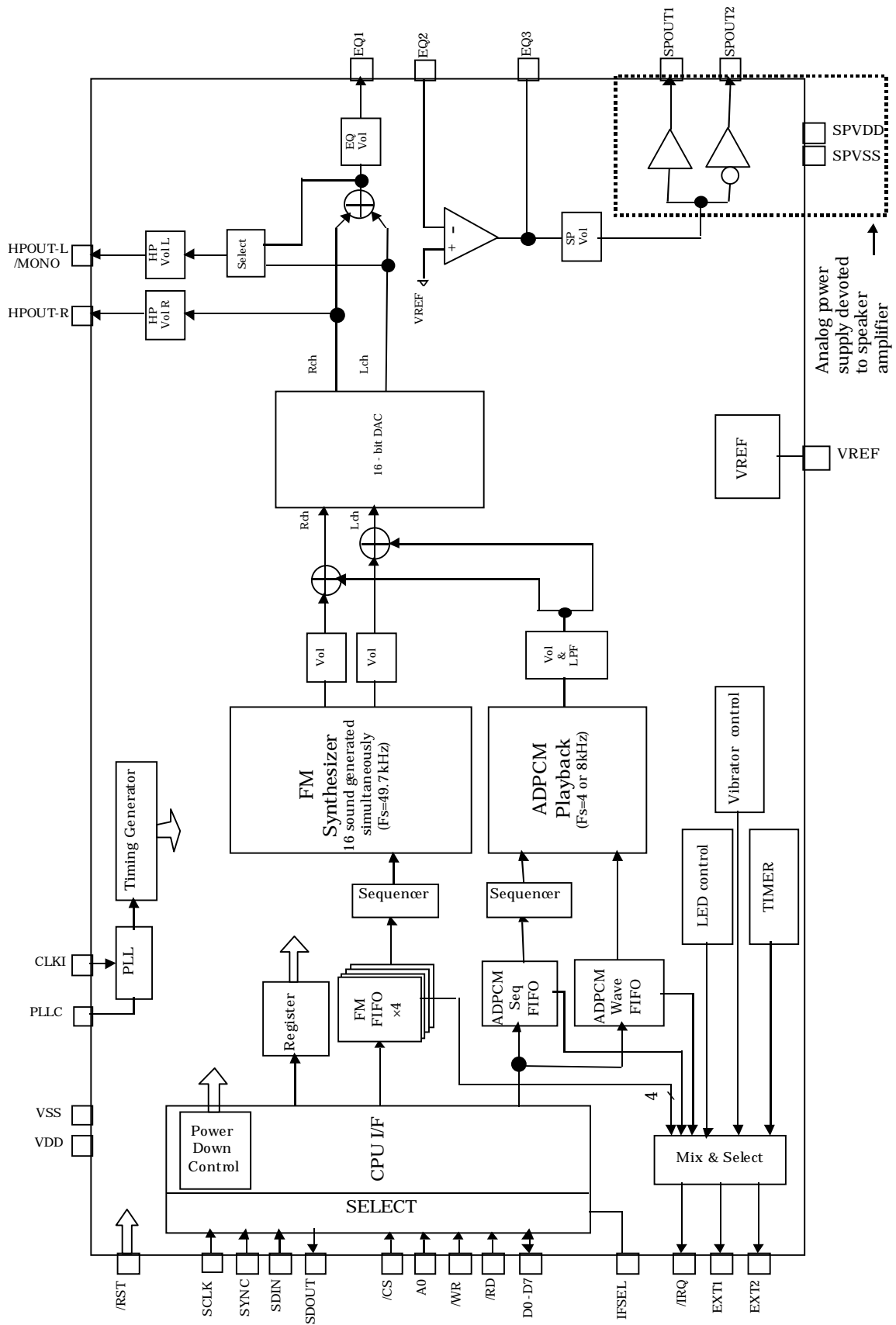

## Outline of blocks

Explanation about outline of built-in each blocks and flow of the signal are follows.

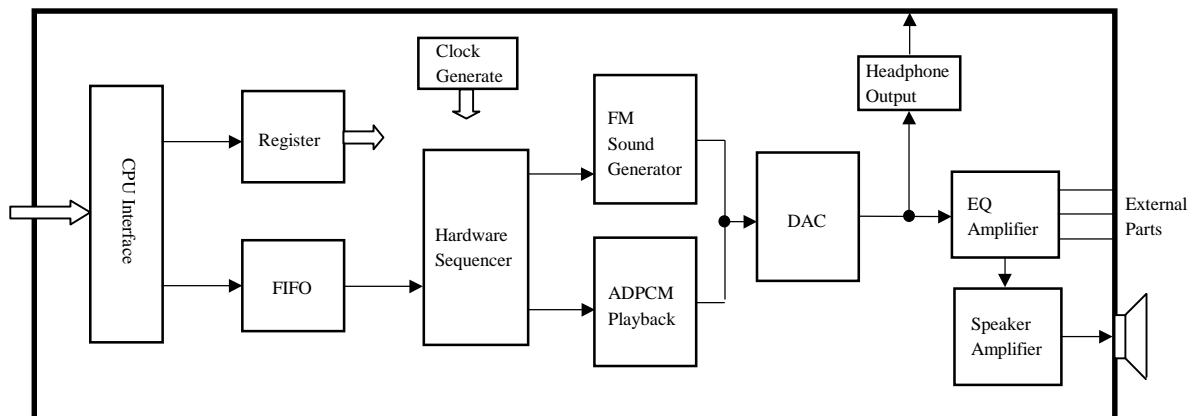

### CPU interface

Receives commands send from external CPU, interprets the contents, and then writes them into registers by index address. Controls reading of designated register data.

As interfaces for controlling YMU759, 4 wire serial and 12 wire parallel interfaces are provided, which can be selected through IFSEL terminal.

### Registers

Register groups that control the LSI except for sequence data.

FM tone register data, various volumes and other control data are store here.

### FIFO

Sequence data to move hardware sequencer and ADPCM wave data are stored in FIFO.

This device is equipped with four FIFOs for FM and two FIFOs for ADPCM.

The FIFOs for FM stores sequence data and those for ADPCM stores sequence and waveform data. The size of FIFOs for FM is 96 bytes, the one for ADPCM data is 384 bytes, and the one for sequence data is 32 bytes.

### Hardware sequencer

FIFO is provided as a previous stage of the sequencer which reads sequence data from FIFO to control FM and ADPCM sections.

The sequence data are compatible with SMAF(Synthetic music Mobile Application Format) proposed by yamaha.

### FM synthesis

This is a synthesis that uses Yamaha's original FM system. It is able to generate up to 16 voices simultaneously.

This section plays in accordance with commands from the sequencer.

It can also play by directly controlling various registers without using the sequencer.

The sampling frequency is 49.7 kHz that complies with stereophonic sound.

### ADPCM playback

This section decodes 4 bit ADPCM data to 16 bit data by using the sampling frequency of 4 kHz or 8 kHz.

It can playback one voice. It playback according to command from sequencer.

And it can playback to control various register directly without using sequencer.

## **DAC**

Converts digital signal from FM and ADPCM section to analog voice signal with resolution of 16 bits.

## **Headphone output**

This section supports stereophonic analog output for the headphone. Monaural output is available by changing the setting. And built in volume adjust output level.

## **EQ amplifier**

This section is used to set the response of filter or the gain by externally connecting a resistor and capacitor.

## **Speaker amplifier**

A speaker amplifier is built in this device, which maximum output is 550 mW at AVDD=3.6 V.

Built in volume adjust output level in front of amplifier.

Low ripple is provided.

## **Clock generate**

This block makes a necessary clock by increasing 2 to 20 MHz clock inputted through CLK1 terminal using the built-in PLL.

The clock generated in this section is supplied to the inside of digital circuit.

## Electrical Characteristics

### Absolute maximum rating

Item	Symbol	Min.	Max.	Unit
SPVDD terminal power supply voltage (Speaker amplifier section)	SPV <sub>DD</sub>	-0.3	6.0	V
VDD terminal power supply voltage (Others)	V <sub>DD</sub>	-0.3	4.2	V
SPOUT1 and SPOUT2 terminal impressed voltage	V <sub>INSP</sub>	-0.3	SPV <sub>DD</sub> +0.3	V
Analog input voltage	V <sub>INA</sub>	-0.3	V <sub>DD</sub> +0.3	V
Digital input voltage	V <sub>IND</sub>	-0.3	V <sub>DD</sub> +0.3	V
Operating ambient temperature	T <sub>OP</sub>	-20	85	°C
Storage temperature	T <sub>STG</sub>	-50	125	°C

Note: VSS = SPVSS = 0V

### Recommended operating conditions

Item	Symbol	Min.	Typ.	Max.	Unit
SPVDD operating voltage (Speaker amplifier section)	SPV <sub>DD</sub>	2.7	3.6	4.5	V
VDD operating voltage (Others)	V <sub>DD</sub>	2.7	3.0	3.3	V
Operating ambient temperature	T <sub>OP</sub>	-20	25	85	°C

Note: VSS = SPVSS = 0V

### DC characteristics

Item	Symbol	Condition	Min.	Typ.	Max.	Unit
Input voltage "H" level	V <sub>IHI</sub>		$0.7 \times V_{DD}$	-	-	V
Input voltage "L" level	V <sub>ILI</sub>		-	-	$0.2 \times V_{DD}$	V
Output voltage "H" level	V <sub>OHI</sub>	I <sub>OH</sub> = (*1)	$0.8 \times V_{DD}$	-	-	V
Output voltage "L" level	V <sub>OHL</sub>	I <sub>OL</sub> = (*1)	-	-	0.4	V
Schmitt width	V <sub>sh</sub>			0.5		V
Input leakage current	I <sub>L</sub>		-10		10	μA
Input capacity	C <sub>I</sub>				10	pF

Note: T<sub>OP</sub>=-20 to 85°C, V<sub>DD</sub>=3.0±0.3V, Capacitor load=50pF

(\*1) /IRQ, , SDOOUT, D0~D7 are I<sub>OH</sub>=-1mA, I<sub>OL</sub>=+1mA, (SDOOUT is only IOL)

EXT1, EXT2 are I<sub>OH</sub>=- 4mA, I<sub>OL</sub>=+ 4mA.



## AC characteristics

/RST, CLKI

Item	Symbol	Min.	Typ.	Max.	Unit
/RST active "L" pulse width	$T_{RSTW}$	1024			$\times \text{CLKI}$
CLKI frequency	$1 / T_{\text{freq}}$	2		20	MHz
CLKI rise time / fall time	$T_r / T_f$			30	ns
CLKI duty	$T_h / T_{\text{freq}}$	30	50	70	%

Note:  $T_{Op} = -20 \sim 85^\circ\text{C}$ ,  $V_{DD} = 3.0 \pm 0.3 \text{ V}$ , Capacitor load = 50 pF.

Input hardware reset at the time VDD is turned on.

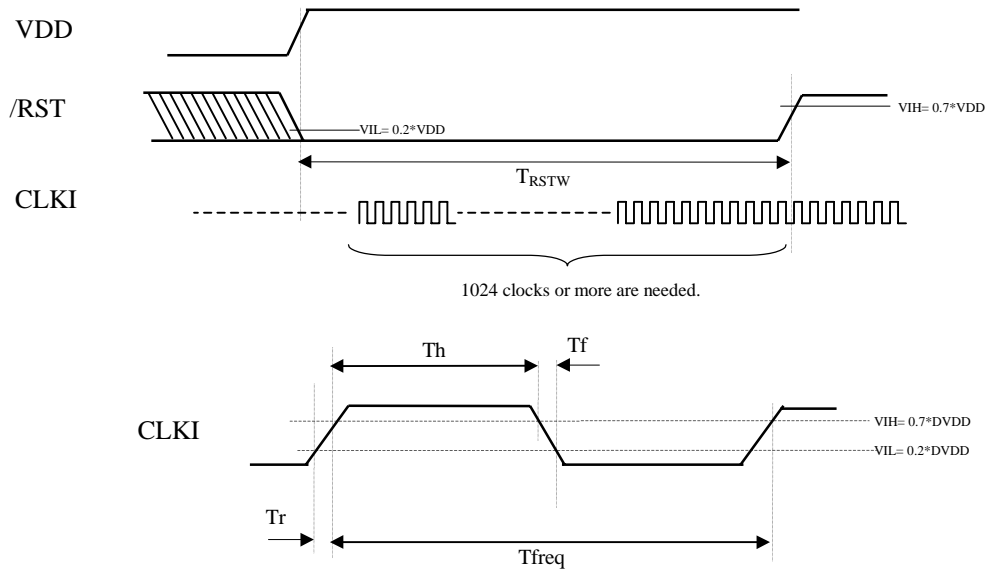

## Serial I/F

Item	Symbol	Min.	Typ.	Max.	Unit
SCLK clock period	Tclk_period	80			ns
SCLK "L" pulse width	Tclk_low	20			ns
SCLK "H" pulse width	Tclk_high	20			ns
SCLK rise time	Trise_clk			30	ns
SCLK fall time	Tfall_clk			30	ns
SYNC "H" pulse width	Tsync_high	30		-	ns
SYNC "L" pulse width	Tsync_low	30			ns
SYNC / SDIN rise time	Trise			30	ns
SYNC / SDIN fall time	Tfall			30	ns
SYNC delay time	Tdelay_SYNC	0			ns
SYNC -> SCLK setup time	Tsetup_SYNC	120			ns
SDIN setup time	Tsetup_SDIN	20			ns
SDIN hold time	Thold_SDIN	20			ns
SDOUT delay time	Tdelay_SDOOUT			70(*2)	ns
Read wait time	Trd_wait	(*1)			ns

Note: T<sub>Op</sub>= -20 ~ 85°C, VDD=3.0±0.3 V, Capacitor load=50 pF.

(\*1): Read wait time varies in the register which accesses it.

(\*2): Max 70ns is the delay time when it is outputted from the D5 terminal.

Delay time from the SDOOUT terminal varies according to pull-up resistance value and the load capacity of the outside.

Standard delay time can be calculated by step response expression of the RC circuit.

Time to change to the voltage of [power supply of external pull-up resistance × 80%] is as follows.

$$1 - \exp(-t / R * C) = 0.80$$

When R = 1kΩ, C = 50pF, t = 80ns //

"Standard delay time" and the reason why it was written are because resistance value and capacity value swing by the part's own error and the temperature character.

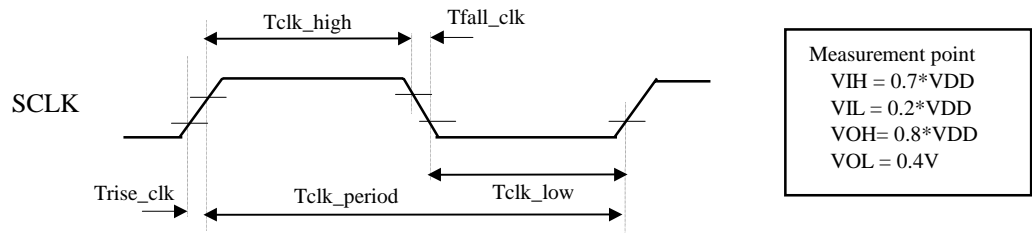

Measurement point  
 $V_{IH} = 0.7 \cdot V_{DD}$   
 $V_{IL} = 0.2 \cdot V_{DD}$   
 $V_{OH} = 0.8 \cdot V_{DD}$   
 $V_{OL} = 0.4V$

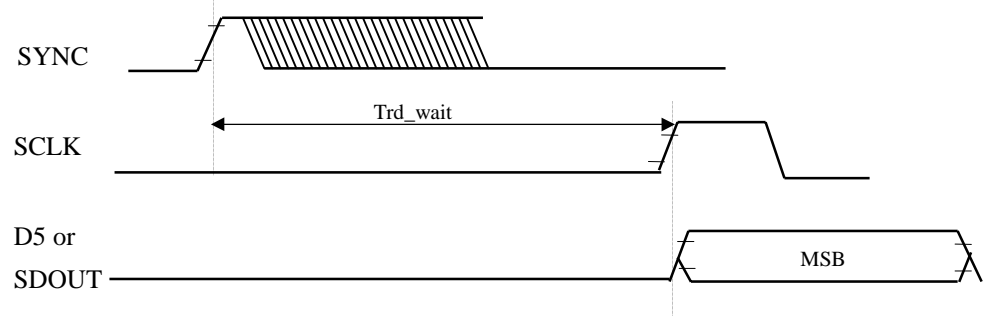
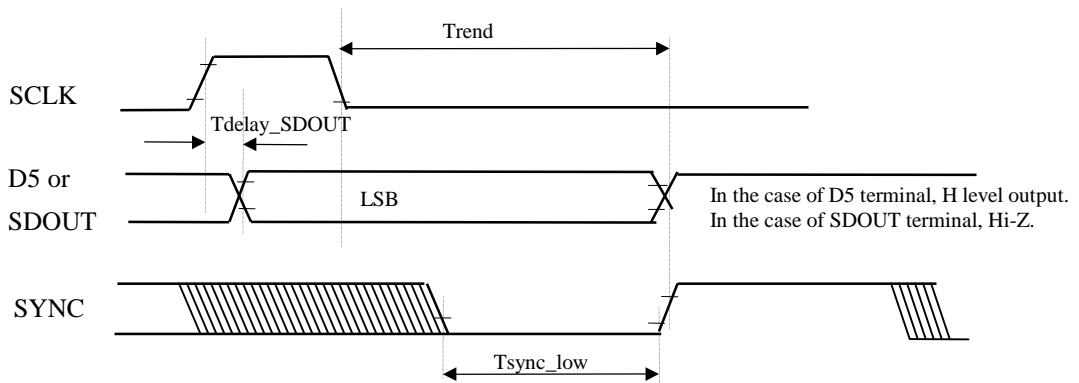
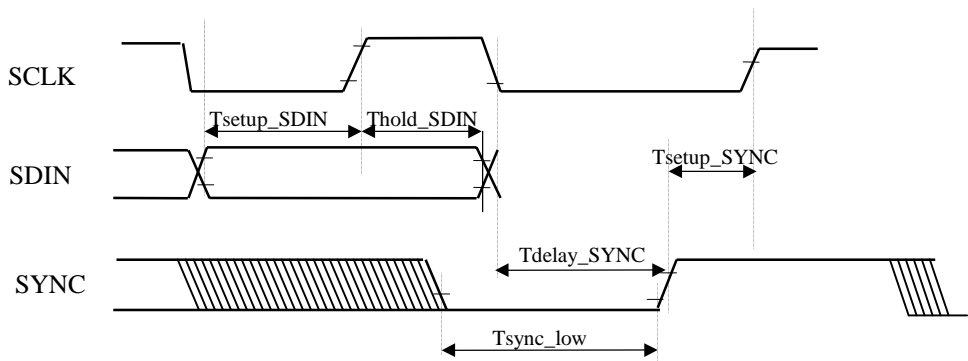
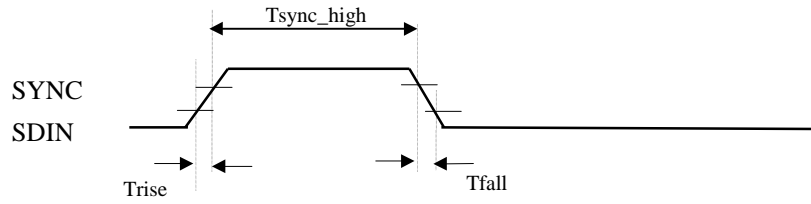

### Parallel I/F (write cycle)

Item	Symbol	Min.	Max.	Unit
Chip select width	$T_{CSW}$	100		ns
Address setup time	$T_{AS}$	10		ns
Address hold time	$T_{AH}$	10		ns
Write pulse width	$T_{WW}$	50		ns
Data setup time	$T_{WDS}$	30		ns
Data hold time	$T_{WDH}$	5		ns

Note:  $T_{Op}=-20 \sim 85^{\circ}\text{C}$ ,  $VDD=3.0\pm 0.3\text{ V}$ , Capacitor load=50 pF.

### (Read cycle)

Item	Symbol	Min.	Max.	Unit
Chip select width	$T_{CSR}$	100		ns
Address setup time	$T_{AS}$	0		ns
Address hold time	$T_{AH}$	0		ns
Read pulse width	$T_{RW}$	80		ns
Read data access time	$T_{ACC}$		70	ns
Data hold time	$T_{RDH}$	10	50	ns

Note:  $T_{Op}=-20 \sim 85^{\circ}\text{C}$ ,  $VDD=3.0\pm 0.3\text{ V}$ , Capacitor load=50 pF.

### Write cycle

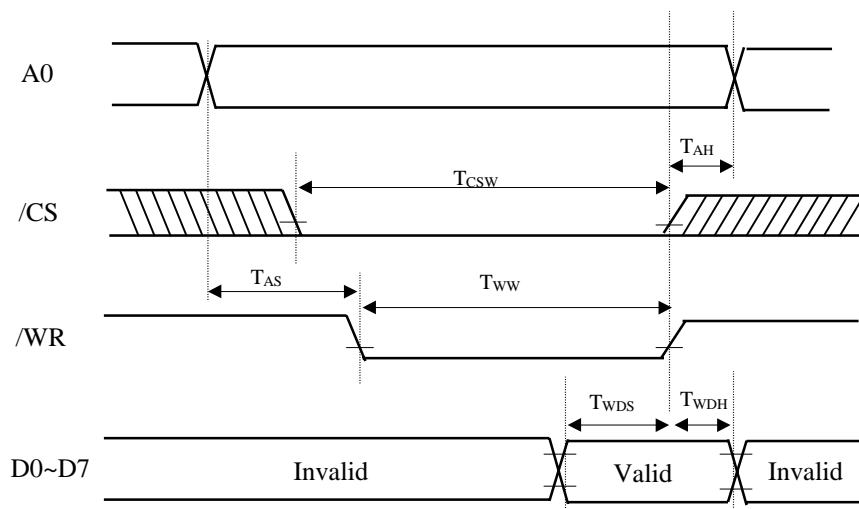

Note:  $T_{CSW}$ ,  $T_{WW}$ ,  $T_{WDH}$  and  $T_{AH}$  are defined with respect to the moment /CS or /WR becomes High level.

Measurement point $V_{IH} = 0.7 \cdot VDD$ $V_{IL} = 0.2 \cdot VDD$ $V_{OH} = 0.8 \cdot VDD$ $V_{OL} = 0.4V$
--

### Read cycle

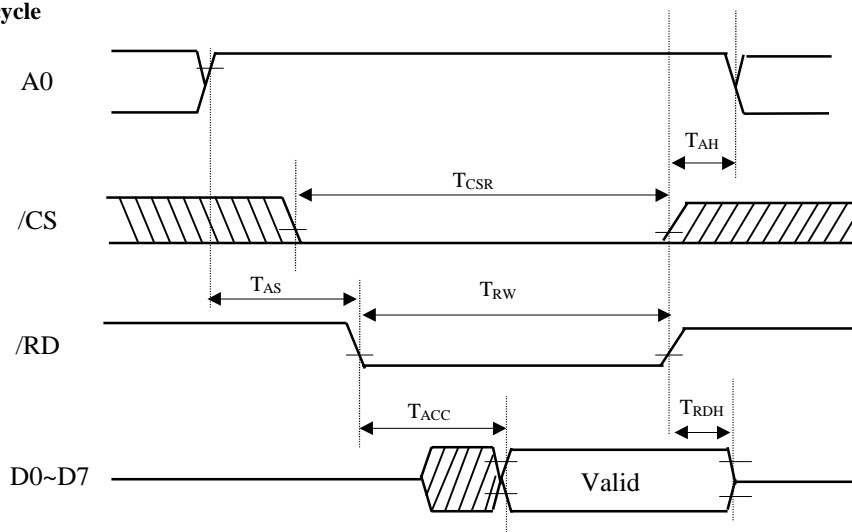

Note:  $T_{ACC}$  is defined with respect to the moment /CS or /RD becomes Low level later.

$T_{CSR}$ ,  $T_{RW}$ ,  $T_{RDH}$  and  $T_{AH}$  are defined with respect to the moment /CS or /RD becomes High level.

Measurement point  
 $V_{IH} = 0.7 \cdot V_{DD}$   
 $V_{IL} = 0.2 \cdot V_{DD}$   
 $V_{OH} = 0.8 \cdot V_{DD}$   
 $V_{OL} = 0.4V$

### Power consumption

Item	Min.	Typ.	Max.	Unit
VDD section (normal operation)		17		mA
SPVDD section (no voice)		5		mA
SPVDD section 8 $\Omega$ load and 400 mW output		210		mA
Power down mode (VDD + SPVDD) (*)		1	10	$\mu$ A

Note:  $T_{Op} = -20 \sim 85^\circ\text{C}$ ,  $V_{DD} = 3.0 \pm 0.3 \text{ V}$ ,  $SPVDD = 3.6 \text{ V}$ .

(\*) Measurement condition : The input terminals except for CLKI are fixed on  $V_{IH} = V_{DD}$ ,  $V_{IL} = 0 \text{ V}$ .

## Analog characteristics

### SP amplifier

Item	Min.	Typ.	Max.	Unit
Gain setting (Fixed)		±2		Times
Minimum load resistance (RL)		8		Ω
Maximum output voltage amplitude (RL=8Ω)		6.0		Vp-p
Maximum output power (RL=8Ω, THD+N<=0.05%)		500		mW
Maximum output power (RL=8Ω, THD+N<=1.0%)		580		mW
THD + N (RL=8Ω, f=1kHz, output=400mW)		0.02		%
Noise at no signal (A-filter: auditory sensation weighting filter)		-90		dBv
PSRR (f=1kHz)		90		dB
Amplitude center voltage (VSEL=0)		× 0.6		VDD
Amplitude center voltage (VSEL=1)		× 0.5		VDD
Differential output voltage		10	50	mV

Note: T<sub>Op</sub>=25°C, VDD=3.0V, SPVDD=3.6V

### EQ amplifier

Item	Min.	Typ.	Max.	Unit
Gain setting range			30	dB
Maximum output current	120			μA
Maximum output voltage amplitude		1.5		Vp-p
THD + N (f=1kHz)			0.05	%
Noise at no signal (A-filter)		-90		dBv
Input impedance	10			MΩ

Note: T<sub>Op</sub>=25 °C, VDD=3.0 V and SPVDD=3.6 V.

### SP Volume

Item	Min.	Typ.	Max.	Unit
Volume setting range	-30		0	dB
Volume step width		1		dB
Noise at no signal (A-filter)		-90		dBv
THD + N (f=1kHz)			0.05	%

Note: T<sub>Op</sub>=25 °C, VDD=3.0 V and SPVDD=3.6 V

## EQ Volume

Item	Min.	Typ.	Max.	Unit
Volume setting range	-30		0	dB
Volume step width		1		dB
Noise at no signal (A-filter)		-90		dBv
Maximum output current	120			$\mu$ A
Maximum output voltage amplitude		1.5		V <sub>p-p</sub>
Output impedance		300	600	$\Omega$

Note: T<sub>Op</sub>=25°C, VDD=3.0V and SPVDD=3.6V.

## HP Volume

Item	Min.	Typ.	Max.	Unit
Volume setting range	-30		0	dB
Volume step width		1		dB
Noise at no signal (A-filter)		-90		dBv
Maximum output current	120			$\mu$ A
Maximum output voltage amplitude		1.5		V <sub>p-p</sub>
Output impedance		300	600	$\Omega$

Note: T<sub>Op</sub>=25°C, VDD=3.0V and SPVDD=3.6V

## VREF

Item	Min.	Typ.	Max.	Unit
VREF voltage		$\times 0.5$		VDD

Note: T<sub>Op</sub>=25°C, VDD=3.0V and SPVDD=3.6V.

## DAC

Item	Min.	Typ.	Max.	Unit
Resolution		16		Bit
Full scale output voltage		1.5		V <sub>p-p</sub>
THD+N (f= 1kHz)			0.5	%
Noise at no signal (A-filter)		-85	-80	dBv
Frequency response (f=50Hz ~20kHz)	-3.0(*1)		+0.5	dB

Note: T<sub>Op</sub>=25°C, VDD=3.0V, SPVDD=3.6V

(\*1): The decline of high range response by aperture effect.

## External dimensions of package

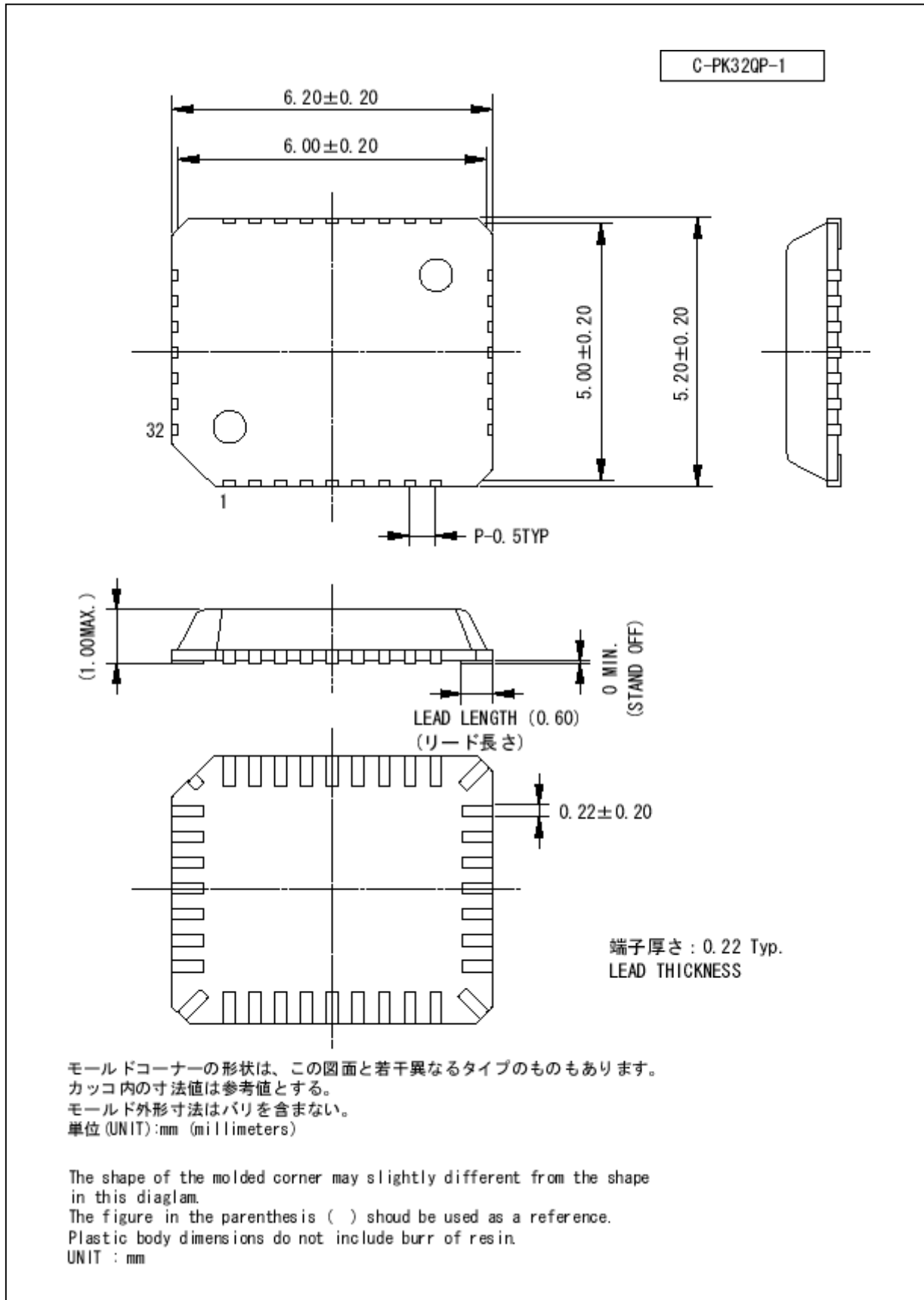



MEMO

## IMPORTANT NOTICE

1. Yamaha reserves the right to make changes to its Products and to this document without notice. The information contained in this document has been carefully checked and is believed to be reliable. However, Yamaha assumes no responsibilities for inaccuracies and makes no commitment to update or to keep current the information contained in this document.
2. These Yamaha Products are designed only for commercial and normal industrial applications, and are not suitable for other uses, such as medical life support equipment, nuclear facilities, critical care equipment or any other application the failure of which could lead to death, personal injury or environmental or property damage. Use of the Products in any such application is at the customer's sole risk and expense.
3. YAMAHA ASSUMES NO LIABILITY FOR INCIDENTAL, CONSEQUENTIAL OR SPECIAL DAMAGES OR INJURY THAT MAY RESULT FROM MISAPPLICATION OR IMPROPER USE OR OPERATION OF THE PRODUCTS.
4. YAMAHA MAKES NO WARRANTY OR REPRESENTATION THAT THE PRODUCTS ARE SUBJECT TO INTELLECTUAL PROPERTY LICENSE FROM YAMAHA OR ANYTHIRD PARTY, AND YAMAHA MAKES NO WARRANTY OR REPRESENTATION OF NON-INFRINGEMENT WITH RESPECT TO THE PRODUCTS. YAMAHA SPECIFICALLY EXCLUDES ANY LIABILITY TO THE CUSTOMER OR ANY THIRD PARTY ARISING FROM OR RELATED TO THE PRODUCTS' INFRINGEMENT OF ANY THIRD PARTY'S INTELLECTUAL PROPERTY RIGHTS, INCLUDING THE PATENT, COPYRIGHT, TRADEMARK OR TRADE SECRET RIGHTS OF ANY THIRD PARTY.
5. EXAMPLES OF USE DESCRIBED HEREIN ARE MERELY TO INDICATE THE CHARACTERISTICS AND PERFORMANCE OF YAMAHA PRODUCTS. YAMAHA ASSUMES NO RESPONSIBILITY FOR ANY INTELLECTUAL PROPERTY CLAIMS OR OTHER PROBLEMS THAT MAY RESULT FROM APPLICATIONS BASED ON THE EXAMPLES DESCRIBED HEREIN. YAMAHA MAKES NO WARRANTY WITH RESPECT TO THE PRODUCTS, EXPRESS OR IMPLIED, INCLUDING, BUT NOT LIMITED TO THE WARRANTIES OF MERCHANTABILITY, FITNESS FOR A PARTICULAR USE AND TITLE.

Note) The specifications of this product are subject to change without notice.

Agency
--------

### Address inquiries to:

#### Semiconductor Sales & Marketing Department

- Head Office 203, Matsunokijima, Toyooka-mura, Iwata-gun, Shizuoka-ken, 438-0192  
Tel. +81-539-62-4918 Fax. +81-539-62-5054
- Tokyo Office 2-17-11, Takanawa, Minato-ku, Tokyo, 108-8568  
Tel. +81-3-5488-5431 Fax. +81-3-5488-5088
- Osaka Office Nanba Tsuzimoto Nissei Bldg. 4F  
1-13-17, Nanbanaka, Naniwa-ku, Osaka City, Osaka, 556-0011  
Tel. +81-6-6633-3690 Fax. +81-6-6633-3691