

## YSS903

### Karaoke Processor 2 for Video disc player (KP2V)

---

#### ■ INTRODUCTION

YSS903(KP2V) is an LSI for processing voice signals of Karaoke system.

This device incorporates an AD(1 channel)/DA(2 channel) and a memory for microphone echo and key control so that the essential functions needed for "Karaoke" such as Key Control, Voice Cancel, Microphone Echo, Tone Control and Surround can be obtained, without requiring other devices.

Since the microphone echo provides reverb-echo in addition to its original function, and the device has the key control function for microphone, it can provide various uses. This device has a register compatible mode in which it can be used in KP2's standard mode.

In addition to these Karaoke programs, this LSI can provide the movie and music program. In this mode, the user is able to enjoy listening movie and music sources by adding surround effect.

#### ■ FEATURES

##### 【Fundamental Functions】

##### 1), Karaoke program

- Key Control (Control by 50 cents in +/- 600 cent range, +/- one octave, etc.)

- Voice Cancel

##### Microphone Echo

- Normal microphone echo (174 msec or less (fs = 44.1 kHz))

- Reverb-Echo

- Microphone Key Control (+/- 10 cents, +/- 20 cents, +/- 400 cents, +/- 700 cents and +/- 1 octave)

##### Tone Control

- Bass, Mid-tone, Treble (0 to +/- 10 dB at 2 dB steps)

##### Surround

- Y mersion (Yamaha's original wide surround function)

##### 2), Movie and music program

##### Surround

- Initial reflection sound synthesizing system

- Y mersion

##### Tone Control

- Bass, Mid-tone, Treble (0 to +/- 10 dB at 2 dB steps)

##### 【I/O Interface】

- Digital inputs : 2 channels (16/18/20/24 bits)

- Digital outputs : 2 channels (16/18/20/24 bits)

- Analog input : 1 channel

- Analog output : 2 channels

- Serial microcomputer interface

- Thru-mode : Outputs digital input without processing it. This mode is compatible with 24 bit DVD format at fs=96 kHz.

##### 【Others】

- KP2 register compatible mode

- Sampling frequency : 32, 37.8, 44.1 or 48 kHz

- Package : 28 pin SOP (YSS903-M)

■ PIN CONFIGURATION

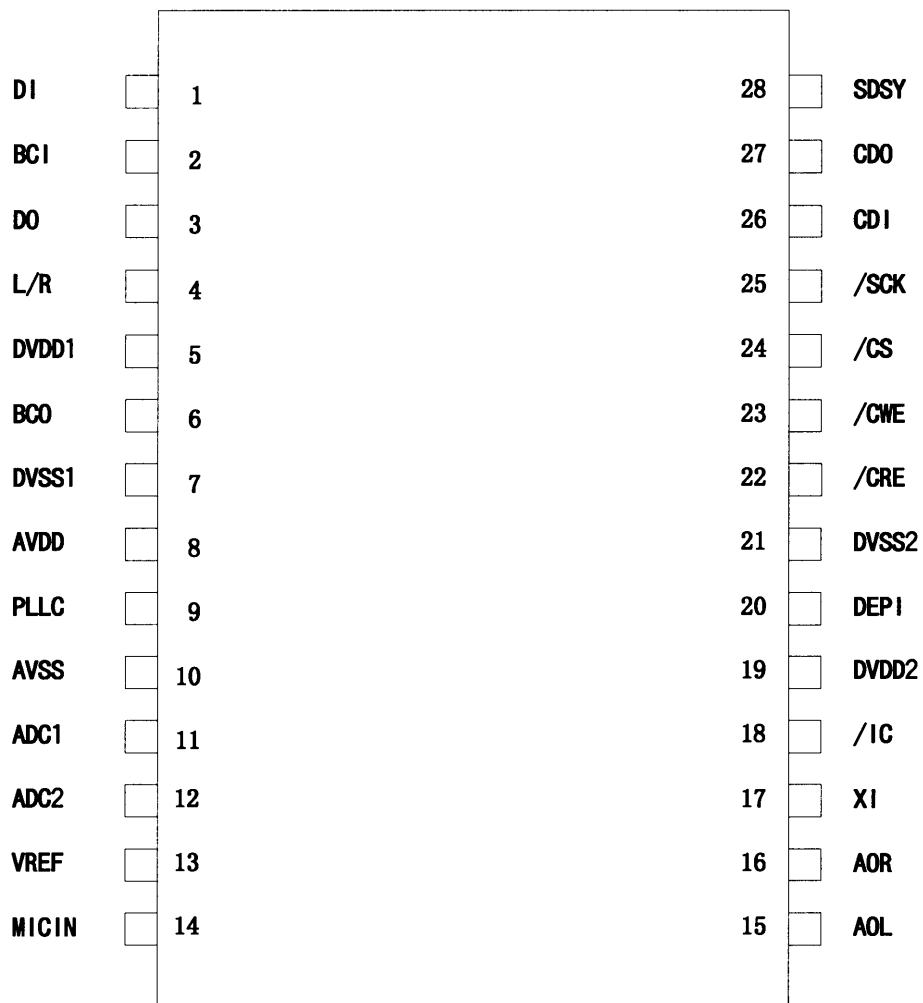

<28pin SOP Top View>

## ■ PIN FUNCTION

No	name	I/O(See Note 1)	Function
1	DI	I+	Digital audio input      Serial data
2	BCI	I+	Digital audio input      Bit clock
3	DO	O	Digital audio output      Serial data
4	L/R	O	Digital audio output      Word clock
5	DVDD1	—	Power supply, +5 V (for digital system)
6	BCO	O	Digital audio output      Bit clock
7	DVSS1	—	Ground (for digital system)
8	AVDD	—A	Power supply, +5 V (for analog system)
9	PLLC	—A	Connecting resistor and capacitor for PLL
10	AVSS	—A	Ground (for analog system)
11	ADC1	—A	Connecting capacitor for ADC
12	ADC2	—A	Connecting capacitor for ADC
13	VREF	OA	Referential voltage output
14	MICIN	IA	Analog audio signal, microphone channel, ADC input
15	AOL	OA	Analog audio signal at L channel, DAC output
16	AOR	OA	Analog audio signal at R channel, DAC output
17	XI	I	External clock input
18	/IC	I	Initial clear (Low active)
19	DVDD2	—	Power supply, +5 V (for digital system)
20	DEPI	I	De-emphasis control (H : On, L : Off)
21	DVSS2	—	Ground (for digital system)
22	/CRE	I+ / O	Switching master clock rate (See Note 2.)
23	/CWE	I+ / O	Test terminal. To be open.
24	/CS	I	Microcomputer interface input      Chip select
25	/SCK	I	Microcomputer interface input      Serial clock
26	CDI	I	Microcomputer interface input      Serial data
27	CDO	O	Microcomputer interface output      Serial data
28	SDSY	I+	Digital audio input      Word clock

Notes:

- (1) + : Pull up,    A : Analog terminal
- (2) 384 fs : /CRE terminal to be open.  
256 fs : Pull down /CRE terminal to digital ground through 4.7 kohm resistor.

■ BLOCK DIAGRAM

This LSI has two input channels (L and R) and two output channels (L and R) for digital audio interface. It also has a one bit Delta-Sigma type AD/DA converter (AD 1 channel (microphone) and DA 2 channels (L and R)) that performs Delta-Sigma modulation at its analog block, and decimation/interpolation of 128 times at its DSP. Karaoke audio signal is processed by DSP for processing Karaoke audio signal and RAM for delay. For the details of Karaoke audio signal processing, please refer to "OPERATIONS". The parameters of this LSI are set through CPU interface. For the details of the parameters, please refer to "REGISTERS".

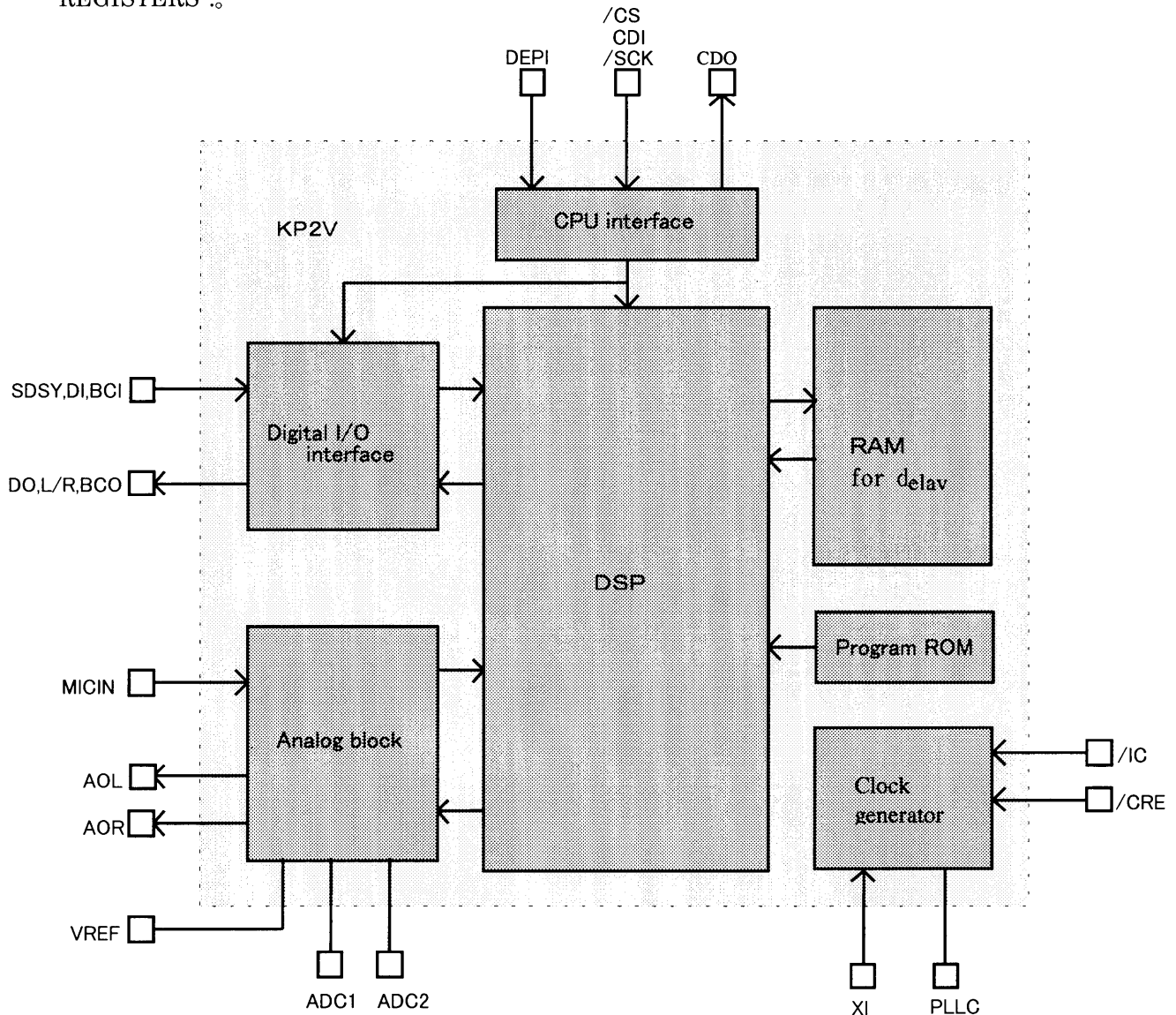

■ MODES

Name of mode	Code	Description
KP2 standard mode	N	The functions of KP2 (YSS216B) can be used. The registers are compatible, except that the coefficient registers (addresses \$27 and \$30 to \$33) of KP2 that controls the analog audio input and analog microphone echo output cannot be used because YSS903 does not have these ports.
KP2V extended mode	E	Every function of this device can be used.

FUNCTIONS

1. Clock signal XI, /CRE, PLLC

Operation of this LSI requires input of clock with frequency of 256 fs (fs : sampling frequency) or 384 fs to XI terminal. Open /CRE terminal when using the 384 fs clock.

Pull down /CRE terminal to the digital ground through 4.7 kohm resistor when using the 256 fs clock.

The sampling frequency is specified by OPR register (\$00). (fs = 32 or 48 kHz can be used only in KP2V extended mode.)

Sampling frequency (fs)	XI input frequency		Available mode (See Note.)
	384fs	256fs	
32.0kHz	12.2880MHz	8.1920MHz	E
37.8kHz	14.5152MHz	9.6768MHz	N,E
44.1kHz	16.9344MHz	11.2896MHz	N,E
48.0kHz	18.4320MHz	12.2880MHz	E

Note.  
N = KP2 standard mode  
E = KP2V extended mode

Connect a resistor and capacitor to PLLC terminal as shown below for adjustment of PLL in the LSI.

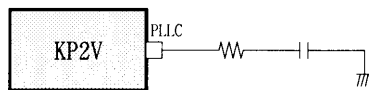

2. Initial clear /IC

This LSI requires initial clear at power on. The initial clear is performed by inputting 'L' to /IC terminal.

3. Analog audio interface MICIN, ADC1, ADC2, AOL, AOR, VREF

This LSI has one channel (microphone input) of Delta-Sigma type AD converter and two channels (audio input L and R) of Delta-Sigma type DA converters.

The following external circuit must be connected to this LSI.

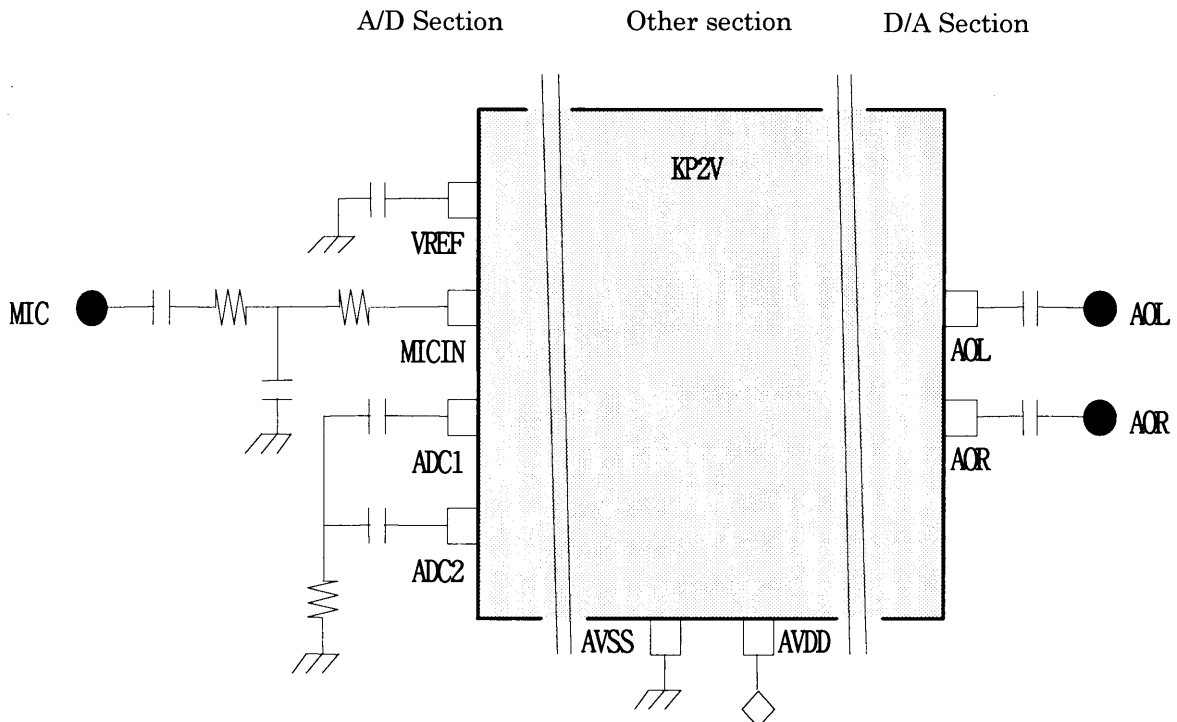

4. Digital audio interface SDSY, BCI, DI, L/R, DO, BCO

4-1) Digital audio signal is inputted through BCI, SDSY and DI pins using the following format.

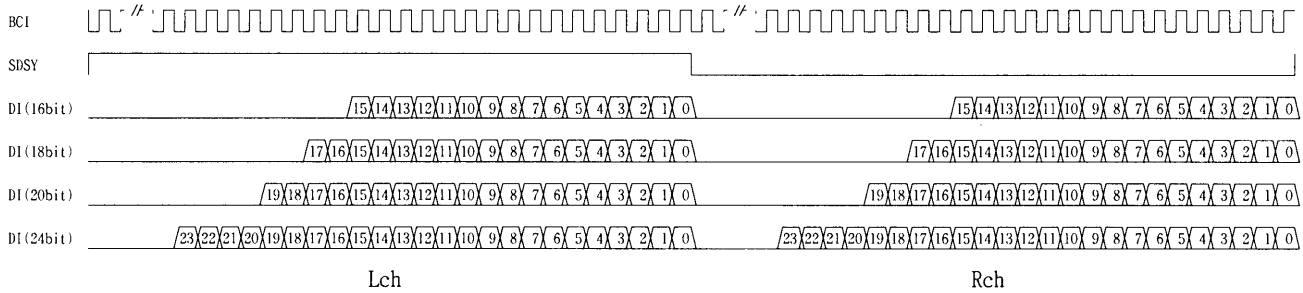

4-2) Digital audio signal is outputted through BCO, L/R, and DO pins using the following format.

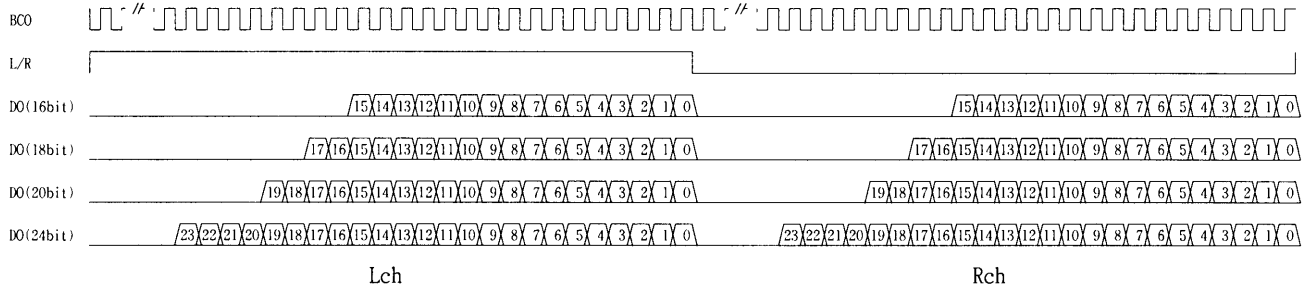

4-3) The digital audio interface is made compatible with the following format with OPR register (\$00) and DAR register (\$04).

Format	BCI	BCO	OPR [5]	DAR [3:2]	Available mode
Format1	-	64fs	1	*	N,E
Format2	32~96fs	64fs	0	0	N,E
Format3	64fs	BCI	0	1	E
	48fs		0	2	
	32fs		0	3	

N=KP2 standard mode  
E=KP2V extended mode

Format1

Use this format when digital audio input is not used.

Format2

Use this format when digital audio input is used.

BCI is able to accept any frequency between and including 32 and 96 fs, while BCO outputs only 64 fs.

BCI, SDSY and DI signals must be synchronized with XI clock.

Format3

Use this format when digital audio input is used.

BCI accepts 32, 48 or 64 fs and BCO outputs inverted clock of BCI.

L/R outputs SDSY delayed by 2.5 clocks with BCI.

BCI, SDSY and DI signals must be synchronized with XI clock.

4-4) Length of data word of the digital audio signal can be set by the DAR register (\$04) to 16, 18, 20 or 24 bits (only in KP2V extended mode). When the data word is 24 bit long, only upper 20 bits are used for processing internal signal.

Length of inputted word	DAR [5:4]	Length of outputted word	DAR [1:0]
16 bits	0	16 bits	0
18 bits	1	18 bits	1
20 bits	2	20 bits	2
24 bits	3	24 bits	3

Note : In KP2 standard mode, both of the input and output word lengths are only 16 bits.

The thru-mode can be selected by using DAR register (\$04) (only in KP2V extended mode).

In thru-mode, BCO outputs inverted clock of BCI, and L/R and DO output SDSY and DI respectively delayed by 2.5 clocks with BCI without being process.

5. Microcomputer interface /CS, /SCK, CDI, CDO, DEPI

These are 8 bit serial interface for writing data into or reading data from internal registers of this device.

Do not write or read data into or from this device in 200 msec from the initial clear moment (rise moment of /IC).

5-1) Writing data

Set the address of an internal register into the first byte, and data into the second byte.

Use the following format.

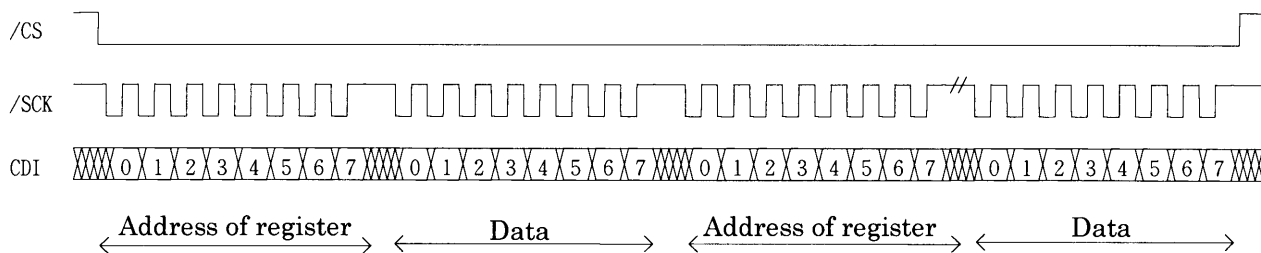

5-2) Reading data (only in KP2V extended mode)

For reading data, only MLR register (\$10) is provided.

Use the following format.

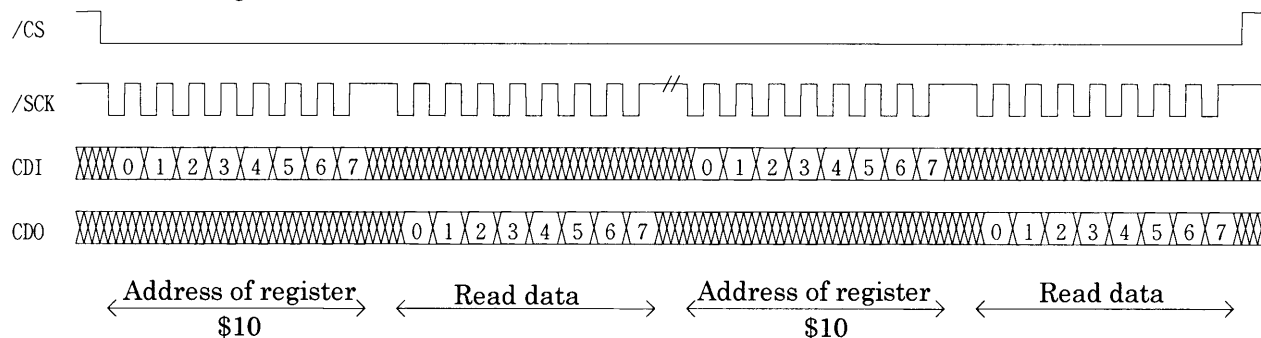

5-3) DEPI

When DEPI is "H", de-emphasis is enabled regardless of the state of internal register. When DEPI is "L", setting of OPR register (\$00) is valid.

OPERATIONS

Process flow chart

1. Karaoke program

Flow of signal in processing Karaoke audio signal in this LSI is as described by the following diagram.

The Karaoke program can be used in both KP2 standard mode or KP2V extended mode.

In KP2 standard mode, the same functions as those of KP2 can be used, and most of the registers of KP2V and KP2 are compatible with each other, except that the registers related to analog audio input and analog microphone echo output cannot be used because KP2V does not have these functions.

In KP2V extended mode, every function of the Karaoke program can be used.

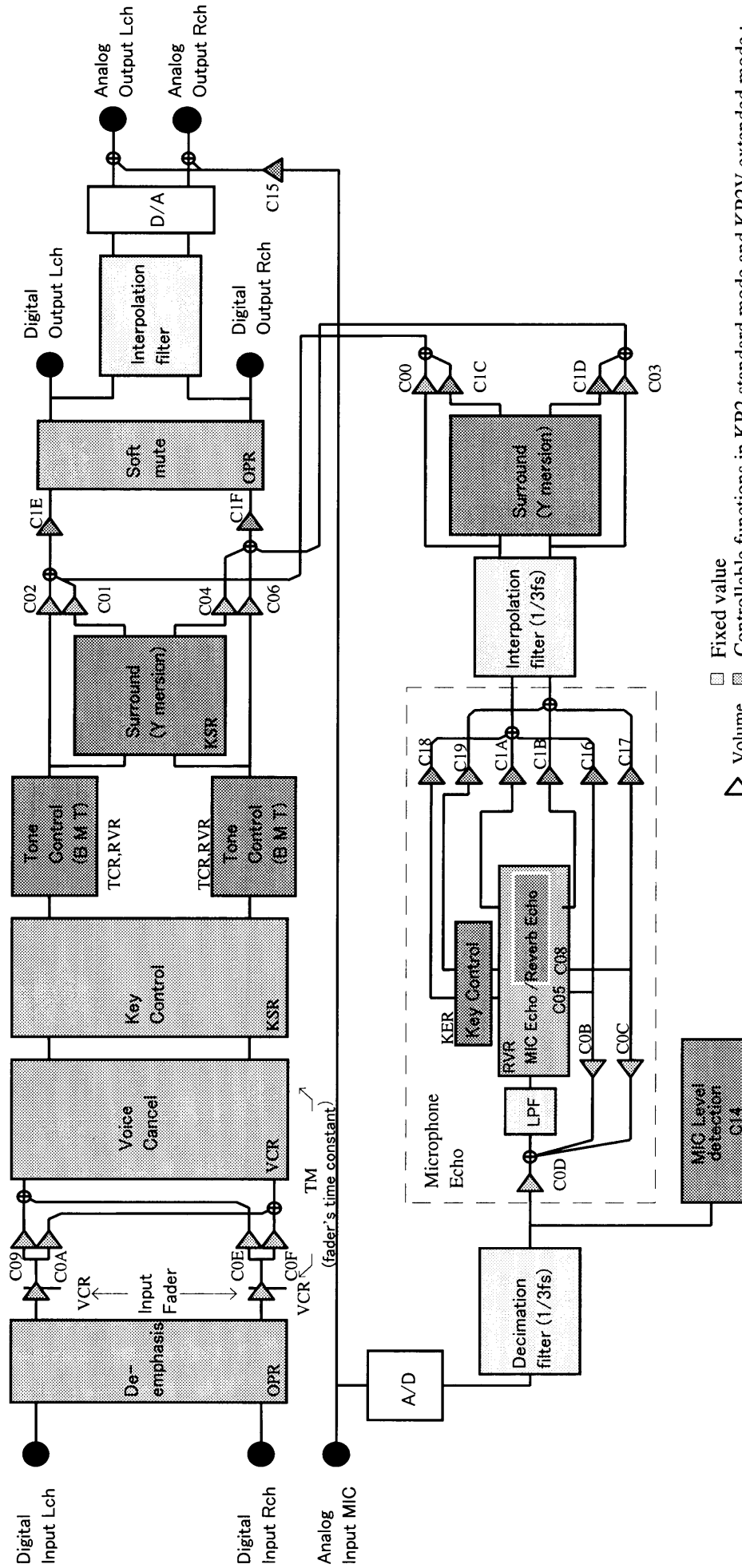



2. Movie and music program

Flow of signal in processing movie and music audio signal in this LSI is as follows  
 The movie or music program can be used in KP2V extended mode

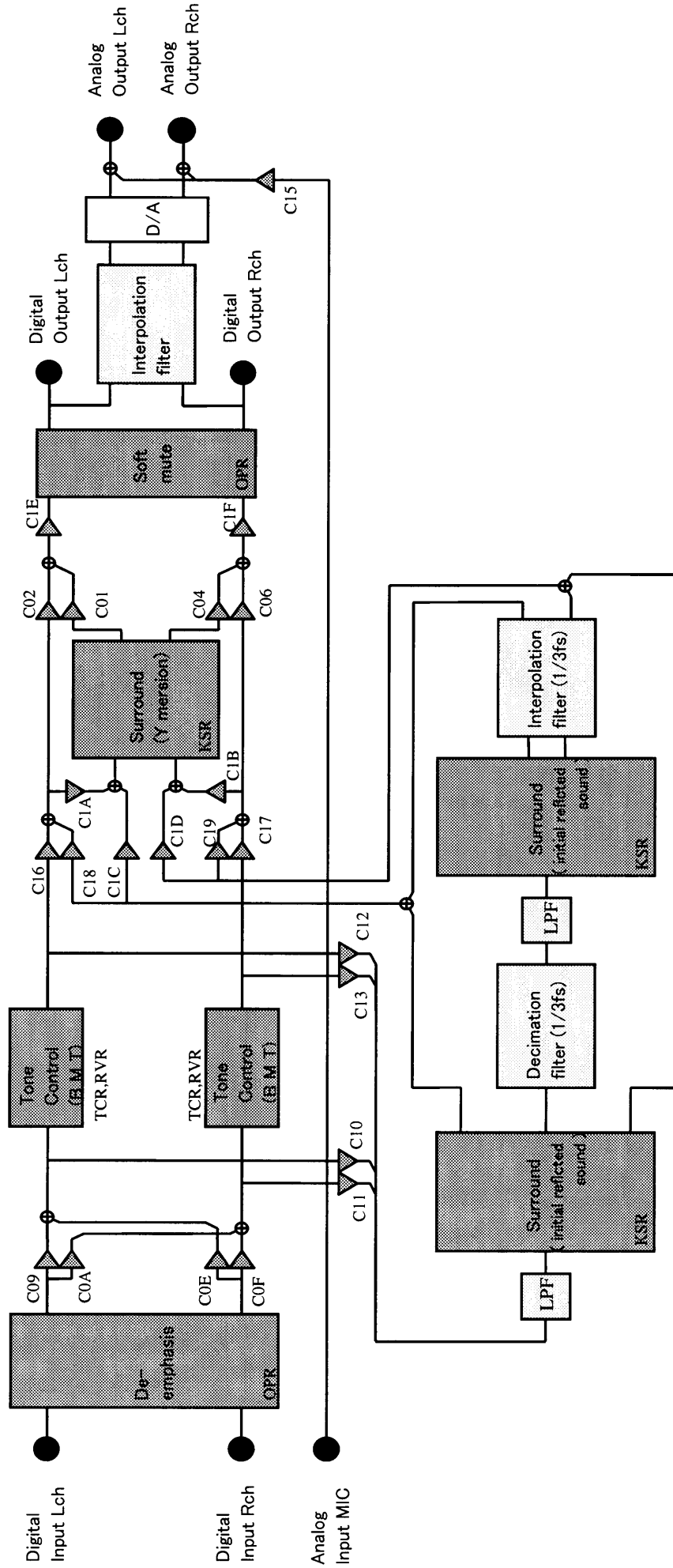

Fixed value  
 Volume  
 Controllable functions only in KP2V extended mode

OPERATIONS OF FUNCTIONS

1. Karaoke program

Function	Description	Control register Coefficient register	Controllable mode
De-emphasis	De-emphasizes audio input signal that has been emphasized. Specifies a sampling frequency and on/off of de-emphasis.	OPR[1] OPR[7:6]	N, E
Input Fader	Controls fade-in/out for audio input signal. Specifies fade-in/out for each channel after setting fade time (See Note.)	VCR[1:0] TMR[7:0]	N, E
Voice Cancel	Reduces mid-range signal of inputted audio signal that is located in the center of the sound field such vocal signal generated by stereophonic CD. Specifies voice cancel on/off after setting sampling frequency and fade time. (See Note.)	VCR[4] TMR[7:0] OPR[7:6]	N, E
Key Control	Changes key of inputted audio signal, and controls key shift for audio input signal. The amount of key shift must be specified.	KSR[4:0]	N, E
Tone Control	Controls tone of inputted audio signal in three frequency bands. Specifies the levels for bass (fc = 200 Hz), treble (fc = 5 kHz), and mid-tone (fc = 1 kHz) after selecting a sampling frequency.	TCR[7:0] RVR[3:0] OPR[7:6]	E
Surround	Applies Y mersion surround to audio input signal. One of four types of surround modes is selected and Output levels for R and L channels are set individually based on the selected surround mode.	KSR[6:5] CO1, CO4	N, E
Microphone level detection	Detects and reads the level of signal input from microphone. Specifies the time constant for level detection.	MLR[7:0] C14	E
Microphone Echo	Applies echo to signal from microphone processed by setting delay and feedback. Specifies delay time, feedback level and output signal level for L/R.	C05, C08, C0B, C0C C16, C17, C00, C03	N, E
Reverberation Echo	Applies microphone echo made by adding reverberation circuit to the delay and feedback of signal inputted from microphone. Specifies delay time, feedback level and output signal level for L/R, and on/off of reverberation.	RVR[4] C05, C08, C0B, C0C, C1A, C1B, C00, C03	E
Microphone key control	Applies microphone echo by subjecting signal inputted from microphone to key shift. Specifies the amount of key shift and output signal level for L/R.	KER[7:0] C18, C19, C00, C03	E
Microphone Y mersion	Applies Y mersion to microphone echo. Specifies output signal level for L/R.	C1C, C1D	E
Soft Mute	Noiseless mute, Specifies on/off.	OPR[3]	N, E
Volume	Controls volume. Some of the functions can be set in either of KP2 standard mode or KP2V extended mode, some only in KP2V extended mode.	C02, C06, C09, C0A C0D, C0E, C0F, C15 C1E, C1F	N, E

Functions for processing the Karaoke audio signals are described here.

## 2. Movie and music program

Functions for processing the movie and music signals are described here.

Function	Description	Control register Coefficient register
De-emphasis	De-emphasizes audio input signal that has been emphasized. Specifies a sampling frequency and on/off of de-emphasis.	OPR[1] OPR[7:6]
Tone Control	Controls tone of inputted audio signal in three frequency bands. Specifies the levels for bass (fc = 200 Hz), treble (fc = 5 kHz), and mid-tone (fc = 1 KHz) after selecting a sampling frequency.	TCR[7:0] RVR[3:0] OPR[7:6]
Surround 1 (Initial reflected sound)	Applies surround that uses initial reflected sound synthesizing system to audio input signal. One of four types of surround modes is selected and Output levels for R and L channels are set individually based on the selected surround mode.	KSR[6:5] C10, C11, C12 C13, C18, C19
Surround 2 (Y mersion)	Applies Y mersion surround to audio input signal. One of two types of surround modes is selected and Output levels for R and L channels are set individually based on the selected surround mode.	KSR[7] C1A, C1B, C1C C1D, C01, C04
Soft Mute	Noiseless mute, Specifies on/off.	OPR[3]
Volume	Controls volume.	C02, C06, C09, C0A, C0E, C0F, C15, C16 C17, C1E, C1F

The movie and music program can be used in KP2V extended mode.

This LSI presents the features of sound field by using a combination of tone control, surround (initial reflected sound) and surround(Y mersion).

The tone control determines frequency characteristics of the sound field.

Initial reflected sound synthesis determines extent and depth of sound field to characterize a surround environment(concert hall and stadium).

Y mersion surround determines size and extent of reverberation.

## ■ REGISTERS

This LSI is controlled by setting data into the registers.

The address, name and function of each register is outlined as follows.

Address	Name	Function
\$00	OPR	Controls internal operations.
\$01	KSR	Controls key and surround.
\$02	VCR	Controls input fader and voice cancel.
\$03	TMR	Controls fade time for input fader and voice cancel.
\$04	DAR	Controls digital audio I/O format.
\$05	TCR	Controls tone (bass, treble).
\$06	RVR	Controls tone (mid-range) and reverb-echo.
\$07	KER	Controls key for microphone.
\$10	MLR	Reads microphone level.
\$1C	MDR	Switching KP2 standard/KP2V extension mode
\$20	C00	Coefficient register (controls volume and delay.)
↓	↓	
\$3F	C1F	

Controllable and uncontrollable registers (bits) vary according to the following modes.  
The mode is specified as follows according to the status of bit 7 of MDR register(\$1C).

Code	Mode	MDR(\$1C)[bit:7]
N	KP2 standard mode	0
E	KP2V extended mode	1

## 1. Functions

Functions, default value and controllable mode are as shown below.

The default value is the value that is set at initial clear or the one obtained in other than the controllable mode.

## 1-1) OPR(\$00): Control of internal operation

bit	Function	Default	Controllable mode
0	Unused (Set this bit to "1".)	1	—
1	Controlling De-emphasis "1" = De-emphasis is disabled. "0" = De-emphasis is enabled. Note : Whenever DEPI is "H", de-emphasis is enable regardless of the status of this bit.	1	N, E
2	Unused (Set this bit to "0".)	1	—
3	Controlling soft mute '1' = Soft mute is off (Fade-in at (1024/fs (sec)) '0' = Soft mute is on (Fade-out at (1024/fs (sec)) Note : fs = sampling frequency (Hz)	1	N, E
4	Controlling internal accumulator output clear on/off '1' = Internal accumulator output clear is on. '0' = Internal accumulator output clear is off (Normal operation).	1	N, E
5	Controlling sync mode '1' = Internal synchronization mode (Digital audio input signals (BCI, SDSY and DI) are not used.) '0' = External synchronization mode (Digital audio input signals (BCI, SDSY and DI) are used.)	1	N, E
6	Selecting sampling frequency 'b7 b6' '0 0' = 37.8kHz '0 1' = 44.1kHz	1	N, E
7	'1 0' = 32.0kHz '1 1' = 48.0kHz Note : The frequencies 32.0 kHz and 48.0 kHz are valid in KP2V extension mode.	0	E

1-2) KSR(\$01): Control of key and surround

bit	Function	Default	Controllable mode
0	Amount of key shift for audio signal key control (This function is valid on Karaoke program. For the correspondence between the setting value for key control and the amount of key shift, refer to the table below.)	0	N, E
1		0	
2		0	
3		0	
4		0	
5	Selecting a type of surround (Y mersion) for Karaoke program, or a type of surround (initial reflected sound) for movie or music program.	0	N, E
6	(For the correspondence between the setting value for key control and the amount of key shift, refer to the table below.)	0	
7	Selecting a surround mode for Y mersion (valid in movie and music mode) '0' = MODE0 '1' = MODE1	0	E

【 Correspondence between the setting value for key control and the amount of key shift for audio signal 】

KSR			
bit 4-0	Amount of key shift	bit 4-0	Amount of key shift
0F	9-1/2 keys up	1F	1/4 key down
0E	1 octave up	1E	2/4 key down
0D	3-1/2 keys up	1D	3/4 key down
0C	3 keys up	1C	1 key down
0B	2-3/4 keys up	1B	1-1/4 keys down
0A	2-2/4 keys up	1A	1-2/4 keys down
09	2-1/4 keys up	19	1-3/4 keys down
08	2 keys up	18	2 keys down
07	1-3/4 keys up	17	2-1/4 keys down
06	1-2/4 keys up	16	2-2/4 keys down
05	1-1/4 keys up	15	2-3/4 keys down
04	1 key up	14	3 keys down
03	3/4 key up	13	3-1/2 keys down
02	2/4 key up	12	1 octave down
01	1/4 key up	11	7 keys down
00	No key shift	10	9-1/2 keys down

【 Correspondence between the surround type and surround selection bit 】

KSR		
bit 6 5	Surround for Karaoke program (Y mersion)	Surround for movie and music program (Initial reflected sound)
0 0	PSEUDO-STEREOPHONIC SOUND	HALL0 (See Note.)
0 1	LIVE	HALL1 (See Note.)
1 0	MOVIE	STADIUM
1 1	KARAOKE	ROCK CONCERT

Note.: HALL0 : Concert hall that provides standard reverberation  
 HALL1 : Concert hall that provides long reverberation

## 1-3) VCR(\$02): Control of input fader and voice cancel

bit	Function	Default	Controllable mode
0	Controlling fade-in/out at digital audio input L channel '1' = Starting fade in '0' = Starting fade out Note : Before this bit is set, set fade time into TMR (\$03).	0	N, E
1	Controlling fade-in/out at digital audio input R channel '1' = Starting fade in '0' = Starting fade out Note : Before this bit is set, set fade time into TMR (\$03)	0	N, E
2	Unused (Set "0" here.)	0	—
3	Unused (Set "0" here.)	0	—
4	Controlling voice cancel on/off '1' = On (switching from thru-path to voice-canceled path) '0' = Off (switching from voice-canceled path to thru-path) Note : Cross fade time is set into TMR (\$03).	0	N, E
5	Unused (Set "0" here.)	0	—
6	Unused (Set "0" here.)	0	—
7	Unused (Set "0" here.)	0	—

## 1-4) TMR( \$03) : Control of fade time for input fader and voice cancel

bit	Function	Default	Controllable mode
0	Fade time for input fader and voice cancel  Fade time = $1024/fs(\text{sec})$ when TMR=00h  $1048576/fs/TMR(\text{sec})$ when TMR=other than 00h  Note : fs = sampling frequency	0	N, E
1		0	
2		0	
3		0	
4		0	
5		0	
6		0	
7		0	

## 1-5) DAR( \$04) : Control of digital audio I/O format

bit	Function	Default	Controllable mode
0	Selecting digital audio output data word length 'b1 b0' '0 0' = 16 bits	0	E
1	'0 1' = 18 bits '1 0' = 20 bits '1 1' = 24 bits	0	
2	This function is valid when bit 5 of OPR(\$00) = 0. When this bit = 1, the digital audio output synchronizes with internal clock (64 fs). 'b3 b2' '0 0' = Synchronizing with internal clock (64 fs)	0	E
3	'0 1' = Synchronizing with BCI (64 fs) '1 0' = Synchronizing with BCI (48 fs) '1 1' = Synchronizing with BCI (32 fs)	0	
4	Selecting digital audio input data word length 'b5 b4' '0 0' = 16 bits	0	E
5	'0 1' = 18 bits '1 0' = 20 bits '1 1' = 24 bits	0	
6	Selecting an output to digital audio output terminal (BCO, L/R and DO) 'b7 b6' '0 0' = Normal (Internally processed data are outputted.)	0	E
7	'0 1' = BCO, L/R and DO are fixed to "L". '1 0' = BCI, SDDY and DI are thru-outputted. (For the details, refer to 4-4 in Page 7.) '1 1' = Inhibited	0	



1-6) TCR( \$05) : Control of tone (bass, treble)

bit	Function	Default	Controllable mode
0	Controlling level of bass (fc = 200 Hz) (fc = cutoff frequency) (For the correspondence between the setting value for key control and the amount of key shift, refer to the table below.)	0	E
1		0	
2		0	
3		0	
4	Controlling level of treble (fc = 5 kHz) (fc = cutoff frequency) (For the correspondence between the setting value and the level, refer to the table below.)	0	E
5		0	
6		0	
7		0	

1-7) RVR(\$06): Control of tone (mid-range) and reverb echo

bit	Function	Default	Controllable mode
0	Controlling level of mid-tone (fc = 1 kHz) (fc = center frequency) (For the correspondence between the setting value and the level, refer to the table below.)	0	E
1		0	
2		0	
3		0	
4	Controlling reverb on/off (valid for Karaoke program) '0' =Reverb off '1' =Reverb on	0	E
5	Unused (Set this bit to "0".)	0	—
6	Unused (Set this bit to "0".)	0	—
7	Unused (Set this bit to "0".)	0	—

【 Correspondence between the setting value and the level.】

TCR				RVR	
bit 3-0	Level of bass	bit 7-4	Level of treble	bit 3-0	Level of mid-tone
7	Inhibited	7	Inhibited	7	Inhibited
6	Inhibited	6	Inhibited	6	Inhibited
5	+10dB	5	+10dB	5	+10dB
4	+8dB	4	+8dB	4	+8dB
3	+6dB	3	+6dB	3	+6dB
2	+4dB	2	+4dB	2	+4dB
1	+2dB	1	+2dB	1	+2dB
0	0dB	0	0dB	0	0dB
F	-2dB	F	-2dB	F	-2dB
E	-4dB	E	-4dB	E	-4dB
D	-6dB	D	-6dB	D	-6dB
C	-8dB	C	-8dB	C	-8dB
B	-10dB	B	-10dB	B	-10dB
A	Inhibited	A	Inhibited	A	Inhibited
9	Inhibited	9	Inhibited	9	Inhibited
8	Inhibited	8	Inhibited	8	Inhibited

1-8) KER( \$07) : Control of Key for microphone

bit	Function	Default	Controllable mode
0	Amount of key shift for controlling microphone key at L channel (This function is valid on Karaoke program. For the correspondence between the setting value and the amount of key shift, refer to the table below.)	0	E
1		0	
2		0	
3		0	
4	Amount of key shift for controlling microphone key at R channel (This function is valid on Karaoke program. For the correspondence between the setting value and the amount of key shift, refer to the table below.)	0	E
5		0	
6		0	
7		0	

【 Correspondence between the setting value and the amount of key shift 】

KER			
bit 3-0	Amount of key shift at L channel	bit 7-4	Amount of key shift at R channel
7	Inhibited	7	Inhibited
6	Inhibited	6	Inhibited
5	1 octave up	5	1 octave up
4	3-1/2 keys up	4	3-1/2 keys up
3	2 keys up	3	2 keys up
2	20 cents up	2	20 cents up
1	10 cents up	1	10 cents up
0	No key shift	0	No key shift
F	10 cents down	F	10 cents down
E	20 cents down	E	20 cents down
D	2 keys down	D	2 keys down
C	3-1/2 keys down	C	3-1/2 keys down
B	1 octave down	B	1 octave down
A	Inhibited	A	Inhibited
9	Inhibited	9	Inhibited
8	Inhibited	8	Inhibited

1-9) MLR( \$10) : Microphone level read register

bit	Function	Default	Controllable mode
0	Detected microphone level ( unsigned binary of 8bits )	0	E
1		0	
2		0	
3		0	
4		0	
5		0	
6		0	
7		0	

## 1-10) MDR( \$ 1C) : Switching KP2 standard mode/KP2V extended mode, and others

bit	Function	Default	Controllable mode
0	Unused (Set "0" to this bit.)	0	—
1	Unused (Set "0" to this bit.)	0	—
2	Unused (Set "0" to this bit.)	0	—
3	Unused (Set "0" to this bit.)	0	—
4	Selecting karaoke/movie & music program '0' = Karaoke program '1' = Movie & music program (When switching the program, be sure to mute, change the setting of coefficient register and this bit, and then release the mute when 250 ms has passed.)	0	E
5	Controlling built-in DAC '0' = On '1' = Off (Mute)	0	E
6	Switching KP2 standard mode/KP2V extended mode '0' = KP2 standard mode '1' = KP2V extended mode	0	N, E
7	Unused (Set "0" to this bit.)	0	—

## 1-11) C \* \* ( \$ 20 ~ \$ 3F ) : Coefficient registers (Controlling volume and delay)

bit 7	bit 6	bit 5	bit 4	bit 3	bit 2	bit 1	bit 0
C7	C6	C5	C4	C3	C2	C1	C0

C7-C0 : Sets volume coefficient or delay coefficient

- For the addresses of the registers their functions for Karaoke and movie & music programs, refer to the following table and flow chart described in "OPERATIONS" section.
- For the relation between the setting value of coefficient, and volume level and delay time, refer to the formula shown later.
- When the coefficient registers controllable only in KP2V extended mode is used in the KP2 standard mode, the following preset values are used as their coefficient of address, and their setting values are not used.
- The values of the registers are indefinite immediately after turning on the power, be sure to set the register values in the controllable mode before releasing the mute.

【 Name, function, preset value and controllable mode of the addresses  
of the coefficient register for Karaoke program 】

Register address	Name	Function	Preset value	Controllable mode
\$ 20	C00	Echo L channel output mixing level	—	N, E
\$ 21	C01	Surround L channel output mixing level	—	N, E
\$ 22	C02	Audio L channel output mixing level	—	N, E
\$ 23	C03	Echo R channel output mixing level	—	N, E
\$ 24	C04	Surround R channel output mixing level	—	N, E
\$ 25	C05	Microphone echo L channel delay	—	N, E
\$ 26	C06	Audio R channel output mixing level	—	N, E
\$ 27	—	Unused	—	—
\$ 28	C08	Microphone echo R channel delay	—	N, E
\$ 29	C09	Digital input L - L channel mixing level	—	N, E
\$ 2A	COA	Digital input L - R channel mixing level	—	N, E
\$ 2B	COB	Microphone echo L channel feedback level	—	N, E
\$ 2C	COC	Microphone echo R channel feedback level	—	N, E
\$ 2D	COD	Microphone echo input level	—	N, E
\$ 2E	COE	Digital input R - L channel mixing level	—	N, E
\$ 2F	COF	Digital input R - R channel mixing level	—	N, E
\$ 30	—	Unused	—	—
\$ 31	—	Unused	—	—
\$ 32	—	Unused	—	—
\$ 33	—	Unused	—	—
\$ 34	C14	Time constant for microphone level detection	\$ 00	E
\$ 35	C15	Microphone direct sound output mixing level	\$ 1F	E
\$ 36	C16	Microphone echo L channel mixing level	\$ 7F	E
\$ 37	C17	Microphone echo R channel mixing level	\$ 7F	E
\$ 38	C18	Microphone key control L channel mixing level	\$ 00	E
\$ 39	C19	Microphone key control R channel mixing level	\$ 00	E
\$ 3A	C1A	Reverb echo L channel mixing level	\$ 00	E
\$ 3B	C1B	Reverb echo R channel mixing level	\$ 00	E
\$ 3C	C1C	Microphone echo Y mersion L channel mixing level	\$ 00	E
\$ 3D	C1D	Microphone echo Y mersion R channel mixing level	\$ 00	E
\$ 3E	C1E	L channel total output level	\$ 7F	E
\$ 3F	C1F	R channel total output level	\$ 7F	E

【 Name, function, and controllable mode of the addresses of the coefficient register for movie and music program 】

Register address	Name	Function	Controllable mode
\$20	—	Unused	—
\$21	C01	Surround (Y mersion) L channel output mixing level	E
\$22	C02	Audio & surround (initial reflected sound) L channel output mixing level	E
\$23	—	Unused	—
\$24	C04	Surround (Y mersion) R channel output mixing level	E
\$25	—	Unused	—
\$26	C06	Audio & surround (initial reflected sound) R channel output mixing level	E
\$27	—	Unused	—
\$28	—	Unused	—
\$29	C09	Digital input L - L channel mixing level	E
\$2A	COA	Digital input L - R channel mixing level	E
\$2B	—	Unused	—
\$2C	—	Unused	—
\$2D	—	Unused	—
\$2E	COE	Digital input R - L channel mixing level	E
\$2F	COF	Digital input R - R channel mixing level	E
\$30	C10	Surround (initial reflected sound) input 1 L channel mixing level	E
\$31	C11	Surround (initial reflected sound) input 1 R channel mixing level	E
\$32	C12	Surround (initial reflected sound) input 2 L channel mixing level	E
\$33	C13	Surround (initial reflected sound) input 2 R channel mixing level	E
\$34	—	Unused	—
\$35	C15	Microphone direct sound output mixing level	E
\$36	C16	Audio L channel output mixing level	E
\$37	C17	Audio R channel output mixing level	E
\$38	C18	Surround (initial reflected sound) L channel mixing level	E
\$39	C19	Surround (initial reflected sound) R channel mixing level	E
\$3A	C1A	Surround (Y mersion) input 1 L channel mixing level	E
\$3B	C1B	Surround (Y mersion) input 1 R channel mixing level	E
\$3C	C1C	Surround (Y mersion) input 2 L channel mixing level	E
\$3D	C1D	Surround (Y mersion) input 2 R channel mixing level	E
\$3E	C1E	L channel total output level	E
\$3F	C1F	R channel total output level	E

【 Correspondence between setting value and level of C15 】

C15					
bit 7-0	Level	bit 7-0	Level	bit 7-0	Level
00	0 dB	0C	-18.0dB	18	-36.0dB
01	-1.5dB	0D	-19.5dB	19	-37.5dB
02	-3.0dB	0E	-21.0dB	1A	-39.0dB
03	-4.5dB	0F	-22.5dB	1B	-40.5dB
04	-6.0dB	10	-24.0dB	1C	-42.0dB
05	-7.5dB	11	-25.5dB	1D	-43.5dB
06	-9.0dB	12	-27.0dB	1E	-45.0dB
07	-10.5dB	13	-28.5dB	1F	MUTE
08	-12.0dB	14	-30.0dB	20	Inhibited
09	-13.5dB	15	-31.5dB		
0A	-15.0dB	16	-33.0dB	FF	Inhibited
0B	-16.5dB	17	-34.5dB		

【 Relation between setting value of coefficient registers (\$20 to \$3F), and  
volume level and delay time 】

Delay time (C05, C08) =

$$(64 \div fs) \times \sum_{N=0}^6 (C_N \times 2^N) \text{ msec when } \left( \sum_{N=0}^7 (C_N \times 2^N) \leq 119 \right)$$

$$173.5 \text{ msec when } \left( \sum_{N=0}^7 (C_N \times 2^N) \geq 120 \right)$$

Except that  $\sum_{N=0}^7 (C_N \times 2^N) \leq 102$

when Reverb echo On (bit4 of RVR(\$06) = "1")

fs: Sampling frequency [kHz]

Other volume level =

$$\sum_{N=1}^{11} 2^{N-12} \text{ when } C_7=0 \text{ and } C_6=C_5=C_4=C_3=C_2=C_1=C_0=1$$

$$(-1) \times C_7 + \sum_{N=0}^6 (C_N \times 2^{N-7}) \text{ in other case}$$

## ■ ELECTRICAL CHARACTERISTICS

### 1. Absolute maximum ratings

Item	Code	Rating	Unit
Power source voltage	AVDD,DVDD	-0.3 to 7.0	V
Digital input voltage	Vi	-0.5 to DVDD + 0.5	V
Analog input voltage	Vi	-0.5 to AVDD + 0.5	V
Operating temperature	Top	0 to 70	°C
Storage temperature	Tstg	-50 to 125	°C

### 2. Recommended operating conditions

Item	Code	Minimum	Typical	Maximum	Unit
Digital power source voltage	DVDD	4.75	5.00	5.25	V
Analog power source voltage	AVDD	4.50	5.00	5.25	V
Operating temperature	Top	0	25	70	°C

### 3. DC characteristics (Conditions : Ta = 0 to 70 °C, DVDD = 5.0 +/- 0.25 V)

Item	Code	Condition	Minimum	Typical	Maximum	Unit
Power source current	IDD	VDD = 5.0V			80	mA
Input voltage H level	VIH1	(See Note 1)	2.0			V
Input voltage H level	VIH2	(See Note 2)	3.5			V
Input voltage L level	VIL				0.8	V
Input leakage current	ILK		-10		10	μA
Output voltage H level	VOH	IOH = -0.4mA	VDD-1.0			V
Output voltage L level	VOL	IOL = 1.6mA			0.4	V

Notes:

- (1) Applies to input terminals other than XI, /IC, /CRE and /CWE.
- (2) Applies to input terminals XI, /IC, /CRE and /CWE.

### 4. Analog characteristics (Conditions : Ta = 25 °C, DVDD=AVDD = 5.0 V)

Item	Code	Condition	Minimum	Typical	Maximum	Unit
Analog input voltage	VIA	(See Note 1)		(See Note 2)		V
Analog output voltage	VOA	(See Note 3)		2.8		V
DAC ·Total harmonic distortion	THD+N	(See Note 4) 0dB		0.03	0.1	%
·Dynamic range	DR	(See Note 4,5) -60 dB	75	80		dB
·Signal/Noise ratio	S/N	(See Note 4,5) Digital "0"	75	80		dB
ADC ·Total harmonic distortion	THD+N	(See Note 6,7) 0dB		0.04	0.2	%
·Dynamic range	DR	(See Note 6,7,5) -60dB	75	80		dB
Analog through						
·Total harmonic distortion	THD+N	(See Note 8,7) 0dB		0.005	0.02	%
·Dynamic range	DR	(See Note 8,7,5) -60 dB	90	95		dB

Notes: Input signal frequency is 1KHz.

- (1) Peak to peak value. Applies to MICIN terminal
- (2) Any voltage can be used if input resistor attached externally to MICIN is selected properly  
VIA=R/9.4K, When value of a resistor was shown with R,
- (3) Peak to peak value. Applies to AOL and AOR terminals. The output voltage is in proportion to AVDD.
- (4) The signal is outputted through digital inputs to AOL and AOR via DAC.
- (5) Uses IHF-A
- (6) The signal is outputted through MICIN inputs to AOL and AOR via ADC.
- (7) Input resistor attached externally to MICIN : 47 kΩ . 0 dB = 4.65 Vpp
- (8) The signal is outputted through MICIN inputs to AOL and AOR via volume.

## 5. AC characteristics (Conditions : Ta = 0 to 70 °C, DVDD = 5.0 +/- 0.25 V)

Item	Code	Minimum	Typical	Maximum	Unit
XI	Input frequency	fc(See Note 1)	12.0	18.5	MHz
		fc(See Note 2)	8.0	12.5	MHz
XI	Duty factor	Rc	50		%
BCI	Frequency	fBC	1.0	4.7(See Note 3)	MHz
BCI	On/off time	tBO	100(See Note 4)		ns
	Transfer time	tBT		20	ns
DI, SDSY	Setup time	tDS	80(See Note 5)		ns
	Hold time	tDH	80(See Note 5)		ns
DO, L/R	Access time	tD	-20	20	ns
/CS	Setup time	tCS	1/50fs(See Note 6)		s
/SCK	On/off time	tSO	1/50fs(See Note 6)		s
/CS, /SCK	Transfer time	tCT		1/150fs(See Note 6)	s
CDI	Setup time	tSS	1/100fs(See Note 6)		s
	Hold time	tSH	1/100fs(See Note 6)		s
CDO	Access time	tCD	220	600	ns

## Notes:

- (1) XI = 384 fs (See Note 6.)
- (2) XI = 256 fs (See Note 6.)
- (3) 6.2 MHz in thru mode
- (4) 70 ns in thru mode
- (5) 50 ns in thru mode
- (6) fs : sampling frequency



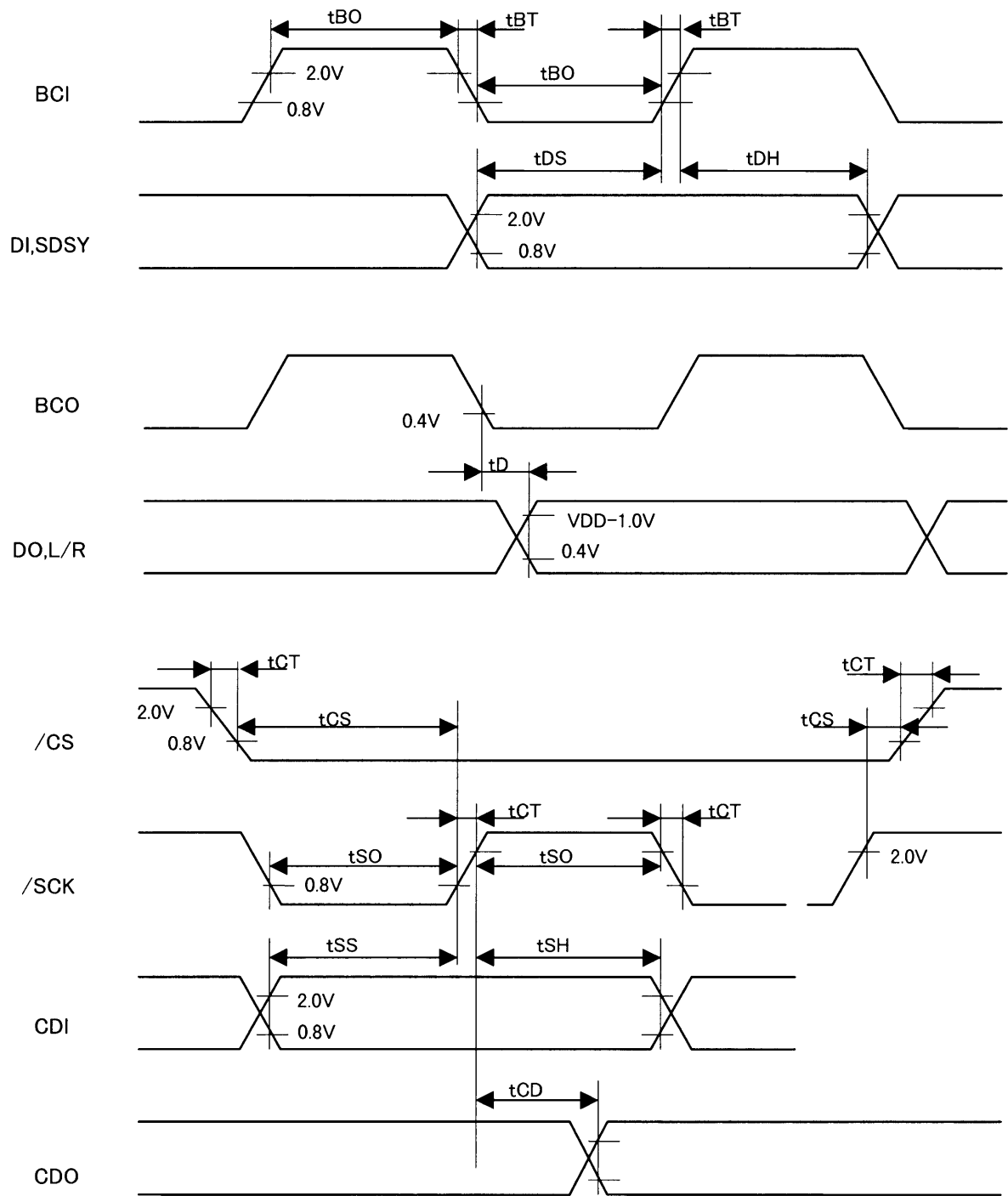

EXTERNAL DIMENSIONS

C-PK28MP-1

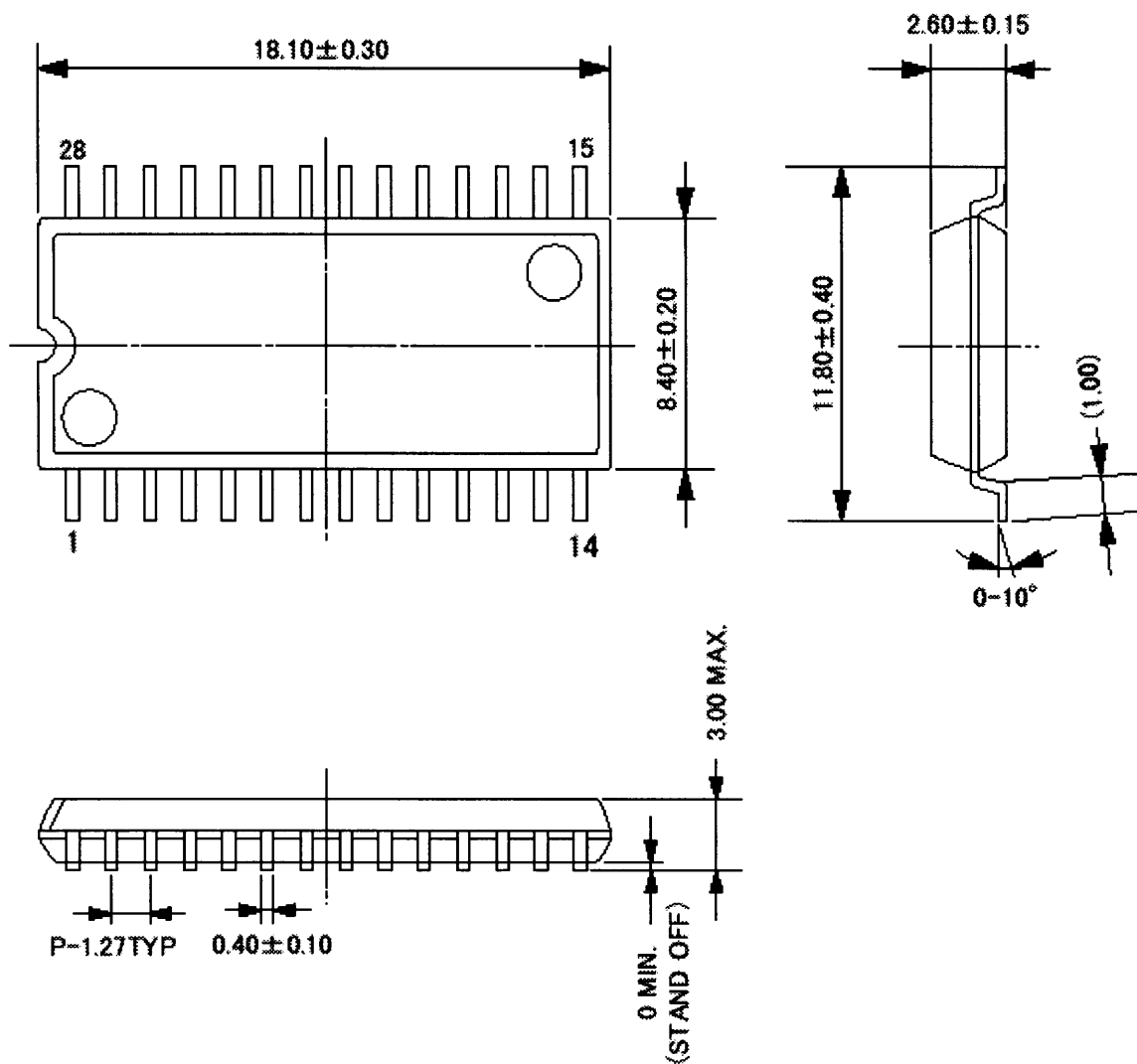

LEAD THICKNESS :  $0.15 \pm 0.10$

The figure in the parenthesis ( )  
Should be used as a reference.  
UNIT:mm



**IMPORTANT NOTICE**

1. Yamaha reserves the right to make changes to its Products and to this document without notice. The information contained in this document has been carefully checked and is believed to be reliable. However, Yamaha assumes no responsibilities for inaccuracies and makes no commitment to update or to keep current the information contained in this document.
2. These Yamaha Products are designed only for commercial and normal industrial applications, and are not suitable for other uses, such as medical life support equipment, nuclear facilities, critical care equipment or any other application the failure of which could lead to death, personal injury or environmental or property damage. Use of the Products in any such application is at the customer's sole risk and expense.
3. YAMAHA ASSUMES NO LIABILITY FOR INCIDENTAL, CONSEQUENTIAL OR SPECIAL DAMAGES OR INJURY THAT MAY RESULT FROM MISAPPLICATION OR IMPROPER USE OR OPERATION OF THE PRODUCTS.
4. YAMAHA MAKES NO WARRANTY OR REPRESENTATION THAT THE PRODUCTS ARE SUBJECT TO INTELLECTUAL PROPERTY LICENSE FROM YAMAHA OR ANYTHIRD PARTY, AND YAMAHA MAKES NO WARRANTY OR REPRESENTATION OF NON-INFRINGEMENT WITH RESPECT TO THE PRODUCTS. YAMAHA SPECIFICALLY EXCLUDES ANY LIABILITY TO THE CUSTOMER OR ANY THIRD PARTY ARISING FROM OR RELATED TO THE PRODUCTS' INFRINGEMENT OF ANY THIRD PARTY'S INTELLECTUAL PROPERTY RIGHTS, INCLUDING THE PATENT, COPYRIGHT, TRADEMARK OR TRADE SECRET RIGHTS OF ANY THIRD PARTY.
5. EXAMPLES OF USE DESCRIBED HEREIN ARE MERELY TO INDICATE THE CHARACTERISTICS AND PERFORMANCE OF YAMAHA PRODUCTS. YAMAHA ASSUMES NO RESPONSIBILITY FOR ANY INTELLECTUAL PROPERTY CLAIMS OR OTHER PROBLEMS THAT MAY RESULT FROM APPLICATIONS BASED ON THE EXAMPLES DESCRIBED HEREIN. YAMAHA MAKES NO WARRANTY WITH RESPECT TO THE PRODUCTS EXPRESS OR IMPLIED, INCLUDING, BUT NOT LIMITED TO THE WARRANTIES OF MERCHANTABILITY, FITNESS FOR A PARTICULAR USE AND TITLE.

Note) The Specifications of this product are subject to improvement changes without prior notice

_____ AGENCY _____
--------------------------

---

**YAMAHA CORPORATION**

---

Address inquiries to:  
Semiconductor Sales & Marketing Department

- Head Office 203, Matsunokijima, Toyooka-mura,  
Iwata-gun, Shizuoka-ken, 438-0192  
Tel. +81-539-62-4918 Fax. +81-539-62-5054
- Tokyo Office 2-17-11, Takanawa, Minato-ku,  
Tokyo, 108-8568  
Tel. +81-3-5488-5431 Fax. +81-3-5488-5088
- Osaka Office Namba Tsujimoto Nissei Bldg. 4F  
1-13-17, Namba Naka, Naniwa-ku,  
Osaka City, Osaka, 556-0011  
Tel. +81-6-6633-3690 Fax. +81-6-6633-3691
- U.S.A. Office YAMAHA Systems Technology  
100 Century Center Court, San Jose,  
CA 95112  
Tel. +1-408-467-2300 Fax. +1-408-437-8791