

File No	RDPS-MF041	
Revision	R0	
System Application	High Speed Digital Services	
Product Type	Dual In-Line filter	
Product Name	MF614A	
Date	Mar. 21 th , 2002	
Issued By	Kevin Lee - Design Engineer, R&D_1	
	kevinlee@ycl.com.tw	
Approved By	Roger Wu - Manager, R&D_1	
	roger@ycl.com.tw	
Issued Date	Mar. 21 th , 2002	



YCL Electronics Co., Ltd.

No.95, Feng Jen Road, Feng Shan City, Kaohsiung County, Taiwan, R.O.C.

This controlled document is the property of YCL Electronics Co., Ltd. Any duplication reproduction or transmission by unauthorized parties without the prior written permission of YCL Electronics Co., Ltd. is prohibited.

Table of contents

<u>Item</u>	<u>Description</u>	<u>Page</u>
1.	Introduction	3
2.	References	4
3.	Abbreviations	4
4.	Technical requirements	5
	4.1. Schematic	5
	4.2. ZHP-r definition	5
	4.3. Electrical specification	6
	4.4. DC characteristics	9
	4.5.1. On hook insertion loss	9
	4.5.2 . Off hook insertion loss	10
	4.5.3 . Return loss	11
	4.5.3.1. Phone port return loss	11
	4.5.3.2. Line port return loss	11
5.	Environmental conditions	12
	5.1. Resistibility to overvoltages and overcurrents	12
	5.2 : Climatic conditions	12
	5.2.1. Operating temperature	12
	5.2.2. Storage and transport	12
	5.2.3. Operation humidity	12
6.	Reliability conditions	13
7.	Mechanical conditions	14
	7.1. Mechanical	14
	7.2. Connector information	14

1. Introduction:

The In-Line filter has been specifically designed to implement the functionality of low pass filter in G.Lite system. G.Lite technology is similar to full rate ADSL in using DMT technology but operates at a lower data rate of up to 1.5 Mbps downstream and 512 kbps upstream, depending on line conditions and lengths.

ADSL Lite is proposed as a lower speed version of ADSL that will eliminate the need for telecom to install and maintain a premise based POTS splitter. Recent field trials of ADSL Lite equipment jointly carried out by a group of manufacturers and a North America network operator has proved the technology, achieving maximum data rate for distance up to 15000 feet, It was found necessary to include one or more low pass filters in series with the POTS terminals in order to reliably achieve maximum data rates. The In-Line filter for phones or telephone equipments sharing a two-line phone jack. The low pass filters provide protection from ADSL signal which may impact through non-linear or other effects remote devices (telephone sets, facsimile machine, answering machine, voice band modem, etc.) on line 1 and line 2. For ADSL signal, it also provides protection from the high frequency transients and impedance effects that occur during POTS operation (ringing transients, on / off hook transients and so on). This In-Line filter provides one filtered jack for any single or two-line phone devices.

Because the In-Line filter connects directly to the subscriber loop media, it must also provide some protection for externally induced line hits or faults which could damage any attached equipments or endanger humans interacting with the installed equipments. The circuit protection will be provided mostly by standard central office line protection means and additional protection measures built into the In-Line filter to protect against line overstress which could damage the In-Line filter itself. The electrical and transmission specifications are designed to meet T1E1.4/2001-007R3 and as per customer' s requirement.

2. References:

Ref. 1 : ETS 300 001	Attachments to the Public Switched Telephone Network (PSTN); General technical requirements for equipment connected to analogue subscriber interface in the PSTN.
Ref. 2 : ANSI T1.413	Network and Customer Installation Interfaces - Asymmetric Digital Subscriber Line (ADSL) Metallic Interface
Ref. 3 : ITU-T G.992.1	Asymmetrical Digital Subscriber Line (ADSL) Transceiver
Ref. 4 : ITU-T G.992.2	Splitterless Asymmetric Digital Subscriber Line (ADSL) Transceivers
Ref. 4 : T1E1.4/2001-007R3	In-Line Filter Standard
Ref. 5 : ITU-T K.21	Resistibility of Telecommunication Equipment Installed in Customer Premises to Overvoltages and Overcurrents
Ref. 6 : ITU-T K.44	Resistibility tests for telecommunication equipment exposed to overvoltages and overcurrents - Basic Recommendation

3. Abbreviations:

ADSL	Asymmetric Digital Subscriber Line
CO	Central Office
CPE	Customer Premise Equipment.
POTS	Plain Old Telephone Service
RT	Remote Terminal
DSL-NT	Network termination of ADSL

4. Technical requirements:

4.1. Schematic:

The following drawing illustrates the schematic of this product.

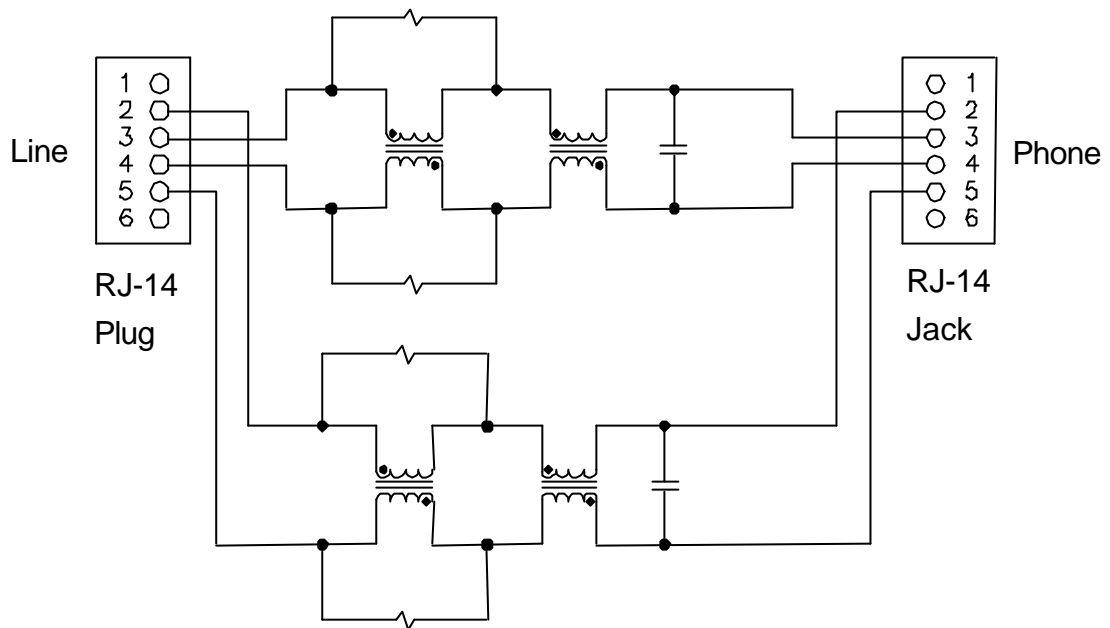

4.2. ZHP-r definition:

To facilitate testing of the In-Line filter independently of the actual modem or specific vendor, ZHP-r is defined to allow proper termination of the Line port during voice band testing. The ZHP-r is valid only for voice band frequency. The combination of capacitors in the ZHP-r is only representative. The input shall be 27nF however derived. ZHP-r equivalent circuit is shown below.

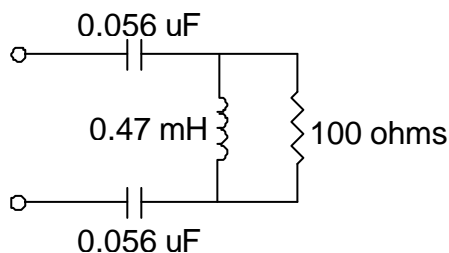

4.3. Electrical specification:

The In-Line filter shall satisfy the following parametric limits which are shown in this table.

Splitter parameters	Electrical requirements	
	Range	Values
Frequency range		
Nominal voice band		200 Hz to 4 kHz
On-hook voice band		200 Hz to 2.8 kHz
Off-hook voice band		200 Hz to 4 kHz
Ringing frequency		15.3 Hz to 68 Hz
High frequency band		25 kHz to 12 MHz
Line Impedance ZNL-r	200 Hz to 4 kHz	1330ohm // (348ohm // 0.1 μF)
Modem impedance	25 kHz to 12 MHz	100 ohm
Operation voltage voice band		
Nominal signal		21 mVpp to 5.4 Vpp
Ringing signal		40 Vrms to 150 Vrms (113Vpp to 424 Vpp)
DC voltage		0 V to 105 V
Max. AC voltage		150 Vrms with -105 VDC offset
Max. differential		320 V
Current voice band		
Loop current		< 100 mA
DC resistance		
Loop resistance (relative to 20 mA)	Tip to Ring 20 mA	Rdc < 25 ohm
	Tip to Ring 5 mA	Rdc + / - 10 %
	Tip to Ring 7 mA	Rdc + / - 10 %
	Tip to Ring 10 mA	Rdc + / - 10 %
	Tip to Ring 90 mA	Rdc + / - 10 %
Isolation resistance	Tip to Ring 0 V to 100 V	> 10 Mohm
	Tip to Ring 100 V to 200 V	> 30 kohm

Splitter parameters	Electrical requirements	
	Range	Values
Voice band characteristics		
Insertion loss (single filter) On-hook	1004 Hz	< +1.5 ~ -0.5 dB
Insertion loss (multiple five filters) On-hook	1004 Hz	< +6.5 ~ -1.0 dB
Insertion loss (single filter) Off-hook	1004 Hz	< +0.5 ~ -0.5 dB
Insertion loss (multiple five filters) Off-hook	1004 Hz	< +1.0 ~ -1.0 dB
Insertion loss distortion (single filter) On-hook (relative to 1004 Hz)	200 Hz to 1 kHz	< +1.5 ~ -1.5 dB
	1 kHz to 2.8 kHz	< +1.5 ~ -1.5 dB
Insertion loss distortion (multiple five filters) On-hook (relative to 1004 Hz)	200 Hz to 1 kHz	< +2.0 ~ -5.5 dB
	1 kHz to 2.8 kHz	< +2.0 ~ -2.0 dB
Insertion loss distortion (single filter) Off-hook (relative to 1004 Hz)	200 Hz to 3.4 kHz	< +0.5 ~ -1.0 dB
	3.4 kHz to 4 kHz	< +1.0 ~ -1.5 dB
Insertion loss distortion (multiple five filters) Off-hook (relative to 1004 Hz)	200 Hz to 3.4 kHz	< +2.5 ~ -1.5 dB
	3.4 kHz to 4 kHz	< +3.25 ~ -2.0 dB
Return loss with four added parallel filters at phone port	ERL	> 9.0 dB
	SRL-L	> 13.0dB
	SRL-H	> 3 dB
Return loss with four added parallel filters at Line port	ERL	> 10 dB
	SRL-L	> 12 dB
	SRL-H	> 5 dB
On / Off-hook delay distortion	200 Hz to 4 kHz	< 250 μ s
Inter-Modulation distortion	2nd	> 57 dB
	3rd	> 60 dB

Splitter parameters	Electrical requirements	
	Range	Values
High frequency band characteristics		
Stop band attenuation On-hook (0 mA)	25 kHz to 50 kHz	> 12 dB
	50 kHz to 12 MHz	> 12 dB
Stop band attenuation Off-hook (20 mA to 90 mA)	25 kHz to 50 kHz	> 21 dB
	50 kHz to 12 MHz	> 25 dB
Stop band attenuation Off-hook (7 mA)	25 kHz to 50 kHz	> 13 dB
	50 kHz to 12 MHz	> 22 dB
Bridging loss Off-hook (single filter)	25 kHz to 1.2 MHz	< 0.5 dB
	1.2 MHz to 12 MHz	< 3 dB
Bridging loss Off-hook (multiple five filters)	25 kHz to 1.2 MHz	< 1.25 dB
	1.2 MHz to 12 MHz	< 4 dB
Transverse balance On-hook (0 mA)	200 Hz to 1 kHz	> 60 dB
	1 kHz to 12 kHz	> 40 dB
	12 kHz to 1.544 MHz	> 35 dB
	1.544 MHz to 12 MHz	> 30 dB
Transverse balance Off-hook (7 mA to 90 mA)	200 Hz to 1 kHz	> 40 dB
	1 kHz to 12 kHz	> 40 dB
	12 kHz to 1.544 MHz	> 35 dB
	1.544 MHz to 12 MHz	> 30 dB

4.4. DC characteristics:

All requirement of this specification can be met in the presence of all POTS loop currents from 0 mA to 100 mA. This In-Line filter can pass POTS tip-to-ring DC voltages of 0 V to 105 V and ringing signals of 40 Vrms to 150 Vrms at any frequencies from 15.3 Hz to 68 Hz with a DC component in the range from 0 V to 105 V. The DC resistance from tip-to-ring at the line port interface with the phone interface shorted, shall be less than or equal to 25 ohms for one filter. The DC resistance from tip-to-ground and from ring-to-ground at the Phone interface with the Line interface open shall be greater than or equal to 10 Megohms. The ground point shall be local building or green wire ground. As an objective, the DC resistance should exceed 10 MΩ.

4.5. Test methods:

4.5.1. On-hook insertion loss:

The insertion loss of a device connected into a given transmission system is defined as the ratio, expressed in dB, of the load power available (before and after insertion) delivered to the output network beyond the point of insertion at a given frequency. In general, the insertion loss is defined as the ratio, expressed in dB of the power delivered to a load with the circuit in place and the power delivered to a load without the circuit in place. The added insertion loss shall be measured using the test setup in figure 1. For measuring POTS band insertion loss for single filter module also for single filter with four added parallel load filters.

General Insertion loss equation can be expressed as follows.

$$\text{Insertion loss} = 20 \log |V2 / V1| \text{ dB where}$$

V1 = the measured voltage value of load without LPF in circuit.

V2 = the measured voltage value of load with LPF in circuit.

The test setup is shown in drawing below.

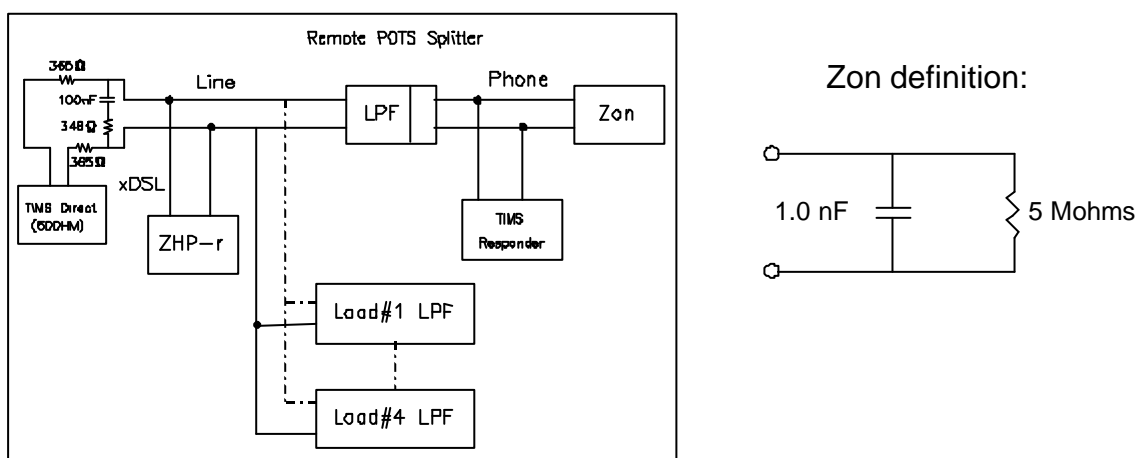

Figure 1.

4.5.2. Off-hook insertion loss:

The insertion loss of a device connected into a given transmission system is defined as the ratio, expressed in dB, of the load power available (before and after insertion) delivered to the output network beyond the point of insertion at a given frequency. In general, the insertion loss is defined as the ratio, expressed in dB of the power delivered to a load with the circuit in place and the power delivered to a load without the circuit in place. The added insertion loss shall be measured using the test up in figure 2. For measuring POTS band insertion loss for single filter module also for single filter with four added parallel load filters. General Insertion loss equation can be expressed as follows.

Insertion loss = $20 \log | V2 / V1 |$ dB where

V1 = the measured voltage value of load without LPF in circuit.

V2 = the measured voltage value of load with LPF in circuit.

The test setup is shown in drawing below.

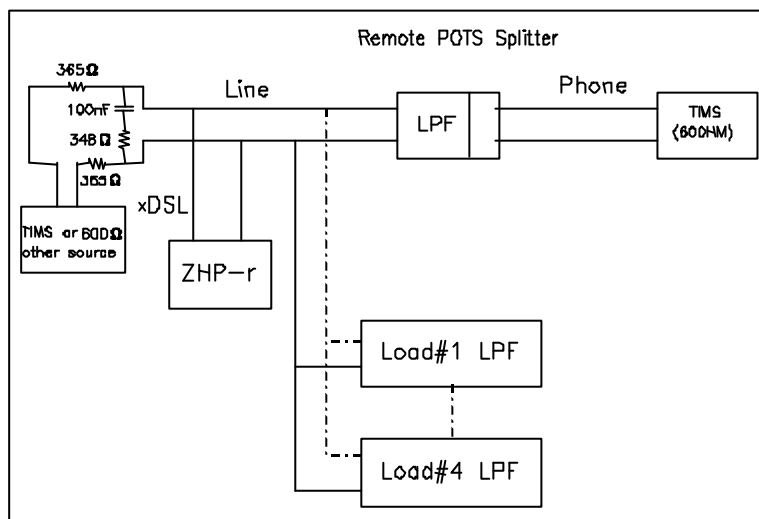

Figure 2.

4.5.3. Return loss:

Return loss measure the amount of energy that is lost due to reflection which resulted from impedance mismatching at the interface. Return loss is essentially defined as the ratio of the power incident upon a given transmission system to the power reflected caused by impedance mismatch with respect to reference impedance at the interface between source and device. Return loss figure are a function of the impedance of the circuit involved and are therefore frequency dependent. These impedance must be closely maintained in order to reduce the possibility of undesirable reflection and echoes which in long distance circuit the telephone user or destroy the data being sent. To perform the return loss test, open, short, load calibration must be done prior measurement while the LCR impedance analyzer being selected in impedance mode. Return loss is general expressed in decibels. General return loss equation is as follows.

$$\text{Return loss} = 20 \log \left| \frac{Z_L + Z_M}{Z_L - Z_M} \right| \text{ dB}$$

Where Z_L = the reference impedance

Z_M = the measured impedance

The test setup is shown in drawing below.

4.5.3.1. Phone port return loss:

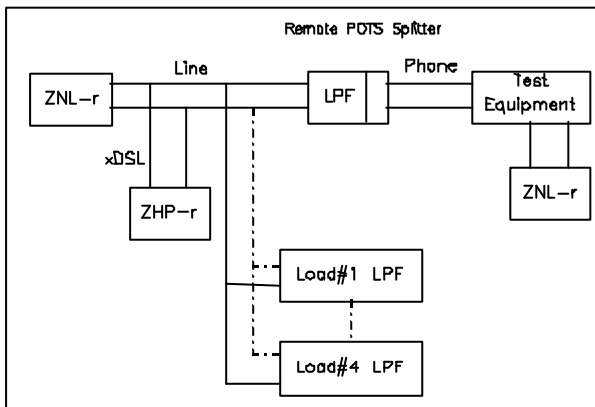

ZNL-r definition:

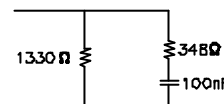
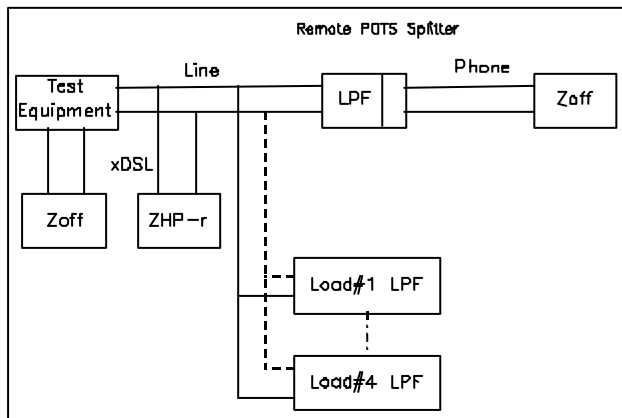

Figure 3.

4.5.3.2. Line port return loss:



Zoff definition:

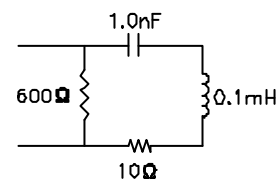

Figure 4.

5. Environmental conditions:

5.1 . Resistibility to overvoltages and overcurrents:

The dual In-Line filter has to comply with requirements as per ITU-T K.21.

5.2. Climatic conditions:

5.2.1. Operating temperature:

Application	indoor
Long time operation guarantee temperature (5 to 40 °C)	
Short time operation guarantee temperature (0 to 50 °C)	
(According to ETS 300 019, class 3.2)	

5.2.2. Storage and transport:

Low ambient temperature	- 20 °C
High ambient temperature	+85 °C
(According to MIL-STD-202 method 107 / QC-0-20)	

5.2.3. Operation humidity:

Long time operation guarantee humidity (5 to 85 %)
Short time operation guarantee humidity (5 to 90 %)
Short time : within 72 continuous hours and 15 days in a year

6. Reliability conditions:

Test Item	Description of Testing	Test Condition	Acceptance	Sampling Quantities	
				D.V.T. Pilot Run	Mass Product
1	Visual/Mechanical Examination	By Visual Examination or by using X-Ray , Microscope etc. to Examine sample.	No cracking , broken , marking color changing and lose marking after washing.	2	4
		Reference:QC-0-12&QC-0-22			
2	Electrical Characteristic	According to clause 4.3 Electrical Specification , pp. 6-8.	No electrical failure.	2	4
		Reference: QC-0-16			
3	Thermal Shock	-20 °C +85 °C , for 5 cycles.	No electrical failure.	1	2
		Reference: MIL-STD-202 method 107 / QC-0-20			
4	Temperature Humidity Exposure	+50 °C / 95 RH , 96 hrs.	No electrical failure.	1	2
		Reference: MIL-STD-202 method 103 / QC-0-11			
5	Vibration Test	Random vibration / Freq. : 5 ~ 500 Hz / Sweep time : 1 hr. / axis / Force : 2.4 grams	No electrical failure & mechanical faults.	1 box	1 box
		Reference: MIL-STD-202 method 204 / QC-0-21			

7. Mechanical conditions:

7.1. Mechanical:

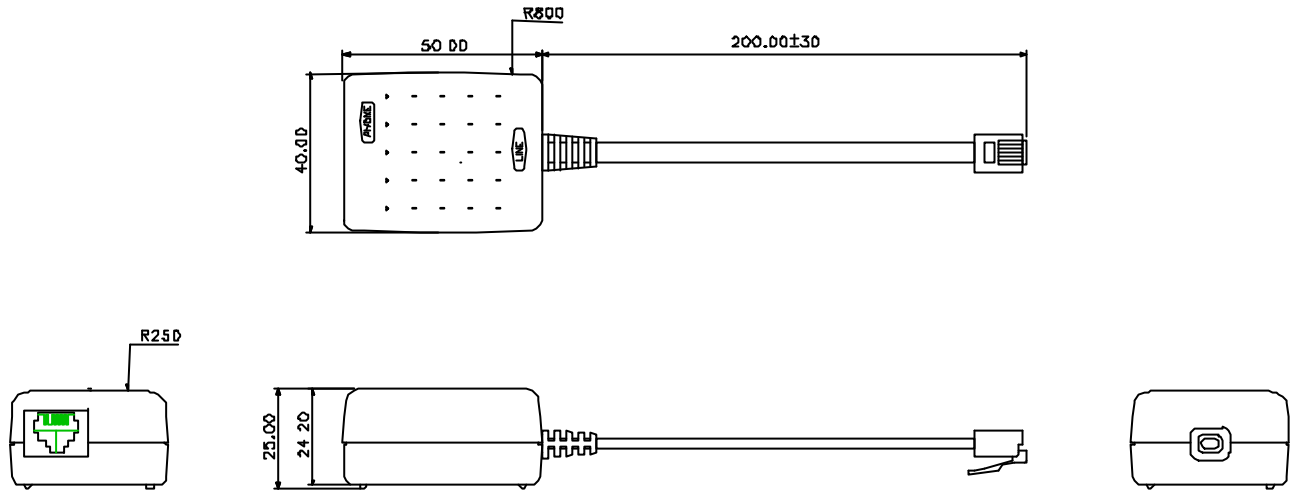

TOLERANCES	
-	±0.5
.X	±0.2
.XX	±0.10

Note: Unit mm

7.2. Connector information:

Position	Type	Tip	Ring
Line 1	RJ 14 Plug (gold plating 50 u")	Pin 3	Pin 4
Phone 1	RJ 14 Jack (gold plating 50 u")	Pin 3	Pin 4
Line 2	RJ 14 Plug (gold plating 50 u")	Pin 2	Pin 5
Phone 2	RJ 14 Jack (gold plating 50 u")	Pin 2	Pin 5