

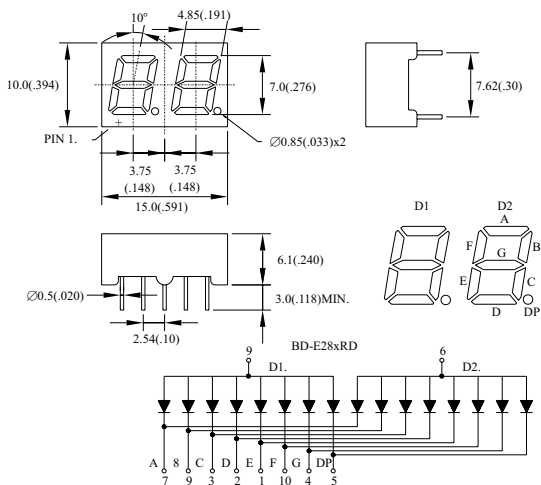
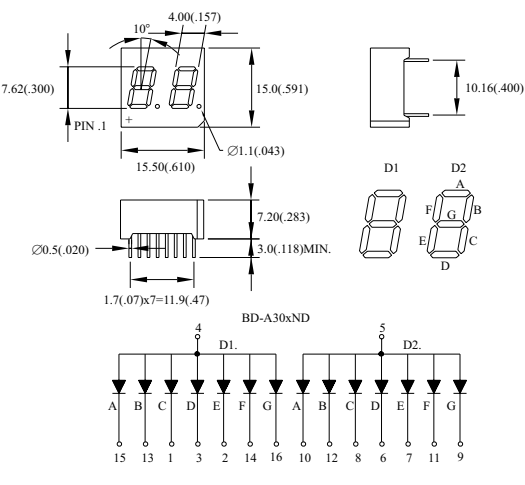
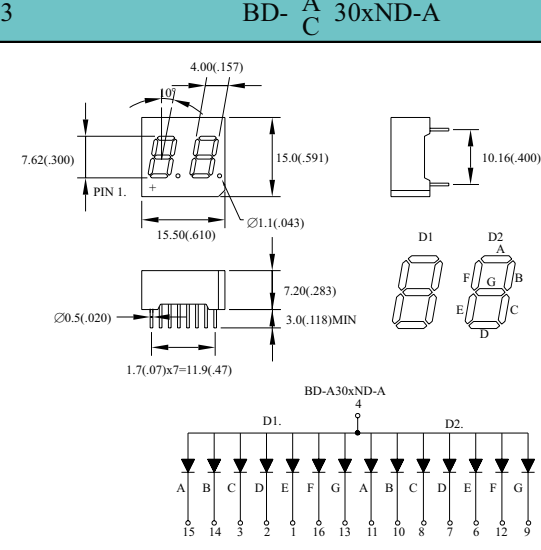
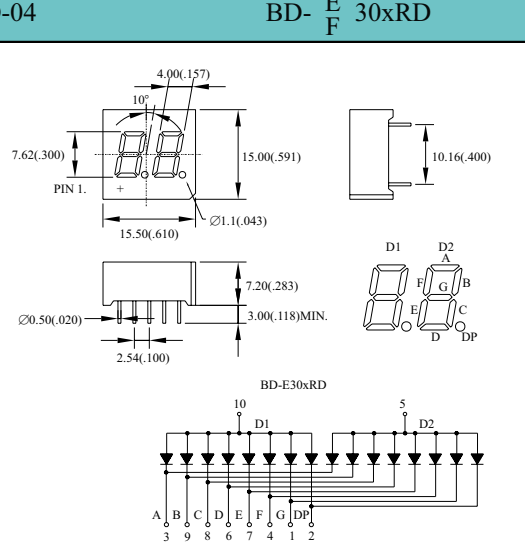
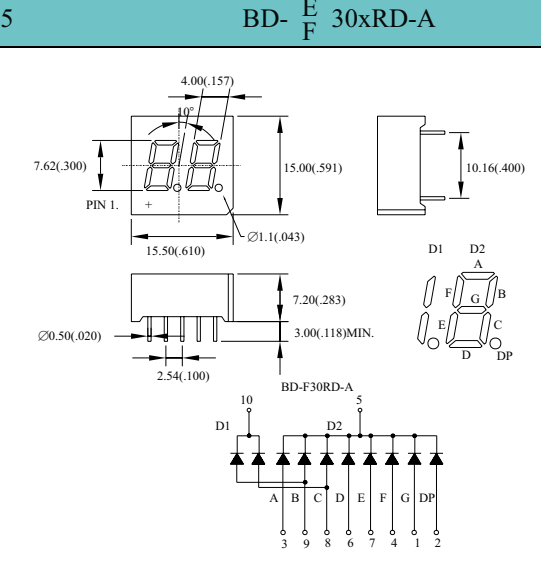
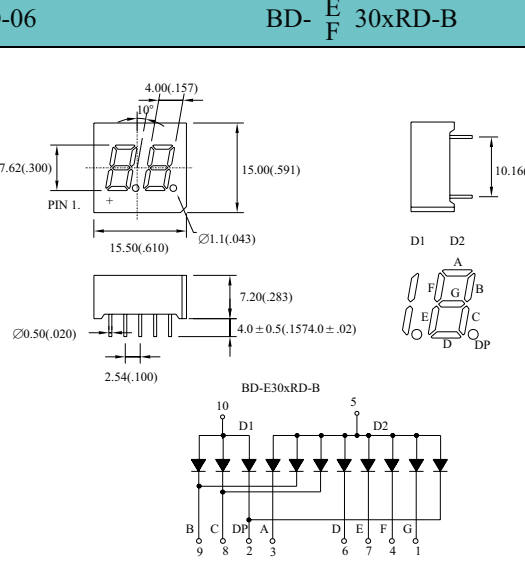

DUAL DIGIT LED DISPLAYS

Digit Size	Part No.		Chip		Absolute Maximum Ratings				Electro-optical Data(At 10mA)			Drawing No.
	Common Anode	Common Cathode	Material/Emitted Color	Peak Wave Length λ_p (nm)	$\Delta \lambda$ (nm)	Pd (mw)	If (mA)	Ifp (mA)	Vf (v)		Iv. Typ. Per.Seg. (mcd)	
									Typ.	Max.		
0.28" Dual-Digit	BD-E281RD	BD-F281RD	GaAsP/Red	655	40	80	40	200	1.7	2.0	0.5	DD-01
	BD-E285RD	BD-F285RD	GaP/ Bright Red	700	90	40	15	50	2.2	2.5	1.0	
	BD-E285RE	BD-F285RE										
	BD-E282RD	BD-F282RD	GaP/ Green	568	30	80	30	150	2.2	2.5	2.5	
	BD-E283RD	BD-F283RD	GaAsP/GaP/ Yellow	585	35	80	30	150	2.1	2.5	2.0	
	BD-E284RD	BD-F284RD	GaAsP/GaP/ Hi-Eff.Red	635	45	80	30	150	2.0	2.5	2.5	
			GaAsP/GaP/ Orange									
	BD-E286RD	BD-F286RD	GaAlAs/ SH Super Red	660	20	80	30	150	1.7	2.5	5.0	
BD-E28DRD	BD-F28DRD	GaAlAs/ DH Super Red	660	20	80	30	150	1.7	2.5	6.0		
0.30" Dual-Digit	BD-A301ND	BD-C301ND	GaAsP/Red	655	40	80	40	200	1.7	2.0	0.6	DD-02
	BD-A305ND	BD-C305ND	GaP/ Bright Red	700	90	40	15	50	2.2	2.5	1.2	
	BD-A305NE	BD-C305NE										
	BD-A302ND	BD-C302ND	GaP/ Green	568	30	80	30	150	2.2	2.5	3.0	
	BD-A303ND	BD-C303ND	GaAsP/GaP/ Yellow	585	35	80	30	150	2.1	2.5	2.0	
	BD-A304ND	BD-C304ND	GaAsP/GaP/ Hi-Eff.Red	635	45	80	30	150	2.0	2.5	3.0	
			GaAsP/GaP/ Orange									
	BD-A306ND	BD-C306ND	GaAlAs/ SH Super Red	660	20	80	30	150	1.7	2.5	6.0	
BD-A30DND	BD-C30DND	GaAlAs/ DH Super Red	660	20	80	30	150	1.7	2.5	7.0		
0.30" Dual-Digit	BD-A301ND-A	BD-C301ND-A	GaAsP/Red	655	40	80	40	200	1.7	2.0	0.6	DD-03
	BD-A305ND-A	BD-C305ND-A	GaP/ Bright Red	700	90	40	15	50	2.2	2.5	1.2	
	BD-A305NE-A	BD-C305NE-A										
	BD-A302ND-A	BD-C302ND-A	GaP/ Green	568	30	80	30	150	2.2	2.5	3.0	
	BD-A303ND-A	BD-C303ND-A	GaAsP/GaP/ Yellow	585	35	80	30	150	2.1	2.5	2.0	
	BD-A304ND-A	BD-C304ND-A	GaAsP/GaP/ Hi-Eff.Red	635	45	80	30	150	2.0	2.5	3.0	
			GaAsP/GaP/ Orange									
	BD-A306ND-A	BD-C306ND-A	GaAlAs/ SH Super Red	660	20	80	30	150	1.7	2.5	6.0	
BD-A30DND-A	BD-C30DND-A	GaAlAs/ DH Super Red	660	20	80	30	150	1.7	2.5	7.0		
0.30" Dual-Digit	BD-E301RD	BD-F301RD	GaAsP/Red	655	40	80	40	200	1.7	2.0	0.6	DD-04
	BD-E305RD	BD-F305RD	GaP/ Bright Red	700	90	40	15	50	2.2	2.5	1.2	
	BD-E305RE	BD-F305RE										
	BD-E302RD	BD-F302RD	GaP/ Green	568	30	80	30	150	2.2	2.5	3.0	
	BD-E303RD	BD-F303RD	GaAsP/GaP/ Yellow	585	35	80	30	150	2.1	2.5	2.0	
			GaAsP/GaP/ Hi-Eff.Red									
	BD-E304RD	BD-F304RD	GaAsP/GaP/ Orange	635	45	80	30	150	2.0	2.5	3.0	
			GaAsP/GaP/ Orange									
BD-E306RD	BD-F306RD	GaAlAs/ SH Super Red	660	20	80	30	150	1.7	2.5	6.0		
BD-E30DRD	BD-F30DRD	GaAlAs/ DH Super Red	660	20	80	30	150	1.7	2.5	7.0		
0.30" Dual-Digit	BD-E301RD-A	BD-F301RD-A	GaAsP/Red	655	40	80	40	200	1.7	2.0	0.6	DD-05
	BD-E305RD-A	BD-F305RD-A	GaP/ Bright Red	700	90	40	15	50	2.2	2.5	1.2	
	BD-E305RE-A	BD-F305RE-A										
	BD-E302RD-A	BD-F302RD-A	GaP/ Green	568	30	80	30	150	2.2	2.5	3.0	
	BD-E303RD-A	BD-F303RD-A	GaAsP/GaP/ Yellow	585	35	80	30	150	2.1	2.5	2.0	
	BD-E304RD-A	BD-F304RD-A	GaAsP/GaP/ Hi-Eff.Red	635	45	80	30	150	2.0	2.5	3.0	
			GaAsP/GaP/ Orange									
	BD-E306RD-A	BD-F306RD-A	GaAlAs/ SH Super Red	660	20	80	30	150	1.7	2.5	6.0	
BD-E30DRD-A	BD-F30DRD-A	GaAlAs/ DH Super Red	660	20	80	30	150	1.7	2.5	7.0		
0.30" Dual-Digit	BD-E301RD-B	BD-F301RD-B	GaAsP/Red	655	40	80	40	200	1.7	2.0	0.6	DD-06
	BD-E305RD-B	BD-F305RD-B	GaP/ Bright Red	700	90	40	15	50	2.2	2.5	1.2	
	BD-E305RE-B	BD-F305RE-B										
	BD-E302RD-B	BD-F302RD-B	GaP/ Green	568	30	80	30	150	2.2	2.5	3.0	
	BD-E303RD-B	BD-F303RD-B	GaAsP/GaP/ Yellow	585	35	80	30	150	2.1	2.5	2.0	
	BD-E304RD-B	BD-F304RD-B	GaAsP/GaP/ Hi-Eff.Red	635	45	80	30	150	2.0	2.5	3.0	
			GaAsP/GaP/ Orange									
	BD-E306RD-B	BD-F306RD-B	GaAlAs/ SH Super Red	660	20	80	30	150	1.7	2.5	6.0	
BD-E30DRD-B	BD-F30DRD-B	GaAlAs/ DH Super Red	660	20	80	30	150	1.7	2.5	7.0		

DUAL DIGIT LED DISPLAYS

DD-01	DD-02
<p style="text-align: center;">BD-$\frac{E}{F}$ 28xRD</p>  <p style="text-align: center;">BD-E28xRD</p>	<p style="text-align: center;">BD-$\frac{A}{C}$ 30xND</p>  <p style="text-align: center;">BD-A30xND</p>
<p style="text-align: center;">BD-$\frac{A}{C}$ 30xND-A</p>  <p style="text-align: center;">BD-A30xND-A</p>	<p style="text-align: center;">BD-$\frac{E}{F}$ 30xRD</p>  <p style="text-align: center;">BD-E30xRD</p>
<p style="text-align: center;">BD-$\frac{E}{F}$ 30xRD-A</p>  <p style="text-align: center;">BD-F30RD-A</p>	<p style="text-align: center;">BD-$\frac{E}{F}$ 30xRD-B</p>  <p style="text-align: center;">BD-E30xRD-B</p>

NOTES: 1.All Dimensions are in millimeters(inches).
3.Specifications are subject to change without notice.

2.Tolerance is $\pm 0.25\text{mm}(.010")$.
4.NP:No Pin. 5.NC:No Connect.