

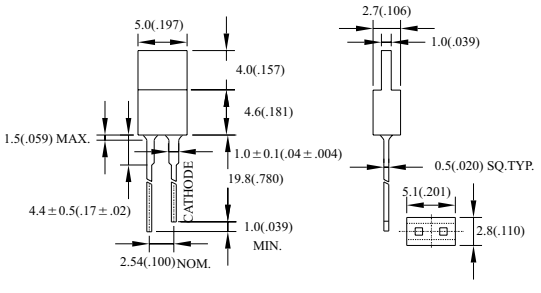
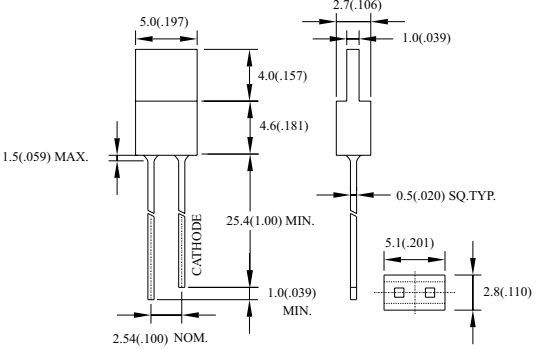
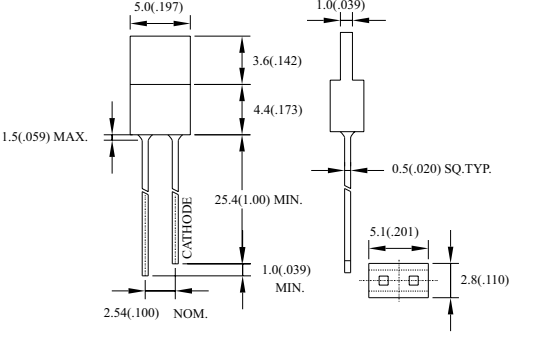
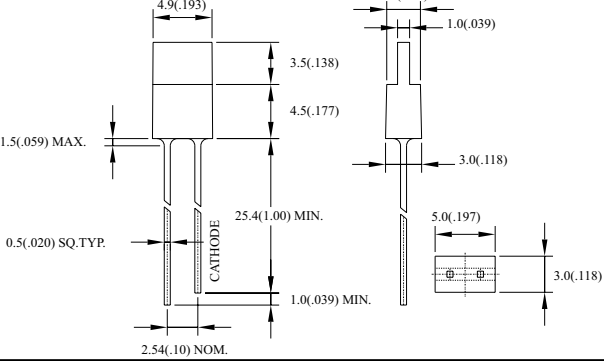
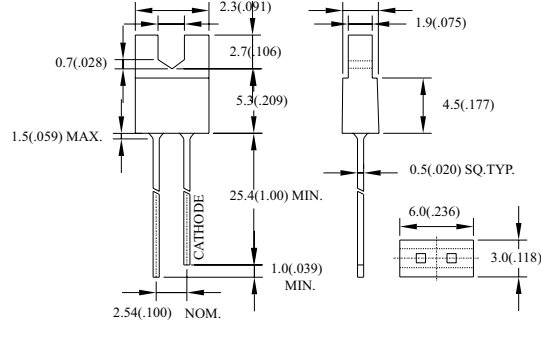
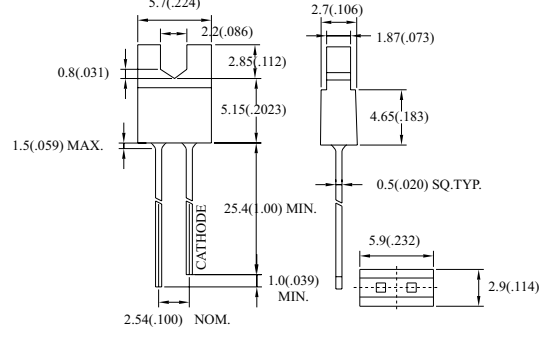
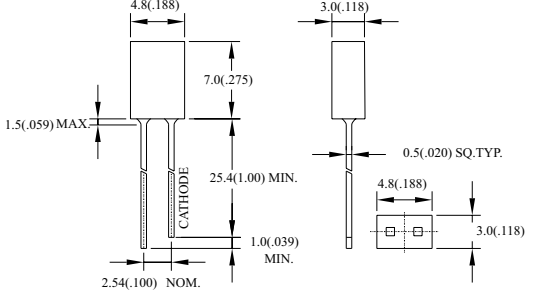
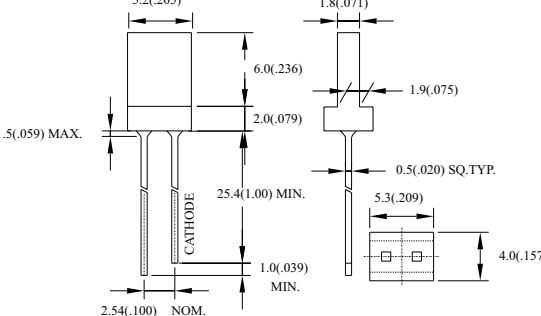

# STANDARD LED LAMPS(RECTANGULAR TYPES)

| Package                              | Part No.   | Chip                     |                          | Lens Appearance | Absolute Maximum Ratings |         |         |           | Electro-optical Data(At 20mA) |     |          | Viewing Angle 2θ 1/2 (deg) | Drawing No. |
|--------------------------------------|------------|--------------------------|--------------------------|-----------------|--------------------------|---------|---------|-----------|-------------------------------|-----|----------|----------------------------|-------------|
|                                      |            | Material/ Emitted Color  | Peak Wave Length λp (nm) |                 | Δλ (nm)                  | Pd (mw) | If (mA) | Peak (mA) | Vf (V)                        |     | Iv (mcd) |                            |             |
|                                      |            |                          |                          |                 |                          |         |         |           | Typ                           | Max | Typ.     |                            |             |
| 1.0x5.0x 8.6mm 0.8" Lead Rectangular | BL-R1115   | GaAsP/GaAs/ Red          | 655                      | Red Diffused    | 40                       | 80      | 40      | 200       | 1.7                           | 2.0 | 0.4      | 120                        | L-089       |
|                                      | BL-R5115   | GaP/GaP/ Bright Red      | 700                      |                 | 90                       | 40      | 15      | 50        | 2.2                           | 2.6 | 0.8      |                            |             |
|                                      | BL-R4515   | GaAsP/GaP/ Hi-Eff Red    | 635                      |                 | 45                       | 80      | 30      | 150       | 2.0                           | 2.6 | 5.0      |                            |             |
|                                      | BL-R2115   | GaP/GaP / Green          | 568                      | Green Diffused  | 30                       | 80      | 30      | 150       | 2.2                           | 2.6 | 5.0      |                            |             |
|                                      | BL-RX1115  | GaAsP/GaP / Hi-Eff Green | 568                      |                 | 30                       | 80      | 30      | 150       | 2.2                           | 2.6 | 8.0      |                            |             |
|                                      | BL-R3115   | GaAsP/GaP/ Yellow        | 585                      | Yellow Diffused | 35                       | 80      | 30      | 150       | 2.1                           | 2.6 | 7.0      |                            |             |
|                                      | BL-R4115   | GaAsP/GaP /Orange        | 635                      | Orange Diffused | 45                       | 80      | 30      | 150       | 2.0                           | 2.6 | 8.0      |                            |             |
| 1.0x5.0x 8.6mm 1.0" Lead Rectangular | BL-R1135   | GaAsP/GaAs/Red           | 655                      | Red Diffused    | 40                       | 80      | 40      | 200       | 1.7                           | 2.0 | 0.8      | 120                        | L-090       |
|                                      | BL-R5135   | GaP/GaP/ Bright Red      | 700                      |                 | 90                       | 40      | 15      | 50        | 2.2                           | 2.6 | 1.5      |                            |             |
|                                      | BL-R4535   | GaAsP/GaP/ Hi-Eff Red    | 635                      |                 | 45                       | 80      | 30      | 150       | 2.0                           | 2.6 | 8.0      |                            |             |
|                                      | BL-R2135   | GaP/GaP / Green          | 568                      | Green Diffused  | 30                       | 80      | 30      | 150       | 2.2                           | 2.6 | 8.0      |                            |             |
|                                      | BL-RX1135  | GaAsP/GaP / Hi-Eff Green | 568                      |                 | 30                       | 80      | 30      | 150       | 2.2                           | 2.6 | 10.0     |                            |             |
|                                      | BL-R3135   | GaAsP/GaP/ Yellow        | 585                      | Yellow Diffused | 35                       | 80      | 30      | 150       | 2.1                           | 2.6 | 7.0      |                            |             |
|                                      | BL-R4135   | GaAsP/GaP / Orange       | 635                      | Orange Diffused | 45                       | 80      | 30      | 150       | 2.0                           | 2.6 | 8.0      |                            |             |
| 1.0x5.0x 8.0mm 1.0" Lead Rectangular | BL-R1135A  | GaAsP/GaAs/ Red          | 655                      | Red Diffused    | 40                       | 80      | 40      | 200       | 1.7                           | 2.0 | 0.8      | 120                        | L-091       |
|                                      | BL-R5135A  | GaP/GaP/ Bright Red      | 700                      |                 | 90                       | 40      | 15      | 50        | 2.2                           | 2.6 | 1.5      |                            |             |
|                                      | BL-R4535A  | GaAsP/GaP/ Hi-Eff Red    | 635                      |                 | 45                       | 80      | 30      | 150       | 2.0                           | 2.6 | 8.0      |                            |             |
|                                      | BL-R2135A  | GaP/GaP / Green          | 568                      | Green Diffused  | 30                       | 80      | 30      | 150       | 2.2                           | 2.6 | 8.0      |                            |             |
|                                      | BL-RX1135A | GaAsP/GaP / Hi-Eff Green | 568                      |                 | 30                       | 80      | 30      | 150       | 2.2                           | 2.6 | 10.0     |                            |             |
|                                      | BL-R3135A  | GaAsP/GaP/ Yellow        | 585                      | Yellow Diffused | 35                       | 80      | 30      | 150       | 2.1                           | 2.6 | 7.0      |                            |             |
|                                      | BL-R4135A  | GaAsP/GaP / Orange       | 635                      | Orange Diffused | 45                       | 80      | 30      | 150       | 2.0                           | 2.6 | 8.0      |                            |             |
| 1.0x4.9x 8.0mm 1.0" Lead Rectangular | BL-R1135B  | GaAsP/GaAs/Red           | 655                      | Red Diffused    | 40                       | 80      | 40      | 200       | 1.7                           | 2.0 | 0.8      | 120                        | L-092       |
|                                      | BL-R5135B  | GaP/GaP/ Bright Red      | 700                      |                 | 90                       | 40      | 15      | 50        | 2.2                           | 2.6 | 1.5      |                            |             |
|                                      | BL-R4535B  | GaAsP/GaP/ Hi-Eff Red    | 635                      |                 | 45                       | 80      | 30      | 150       | 2.0                           | 2.6 | 8.0      |                            |             |
|                                      | BL-R2135B  | GaP/GaP / Green          | 568                      | Green Diffused  | 30                       | 80      | 30      | 150       | 2.2                           | 2.6 | 8.0      |                            |             |
|                                      | BL-RX1135B | GaAsP/GaP / Hi-Eff Green | 568                      |                 | 30                       | 80      | 30      | 150       | 2.2                           | 2.6 | 10.0     |                            |             |
|                                      | BL-R3135B  | GaAsP/GaP/ Yellow        | 585                      | Yellow Diffused | 35                       | 80      | 30      | 150       | 2.1                           | 2.6 | 7.0      |                            |             |
|                                      | BL-R4135B  | GaAsP/GaP / Orange       | 635                      | Orange Diffused | 45                       | 80      | 30      | 150       | 2.0                           | 2.6 | 8.0      |                            |             |
| 1.9x6.0x 8.0mm 1.0" Lead Rectangular | BL-R1136   | GaAsP/GaAs/ Red          | 655                      | Red Diffused    | 40                       | 80      | 40      | 200       | 1.7                           | 2.0 | 0.4      | 120                        | L-093       |
|                                      | BL-R5136   | GaP/GaP/ Bright Red      | 700                      |                 | 90                       | 40      | 15      | 50        | 2.2                           | 2.6 | 0.6      |                            |             |
|                                      | BL-R4536   | GaAsP/GaP/ Hi-Eff Red    | 635                      |                 | 45                       | 80      | 30      | 150       | 2.0                           | 2.6 | 4.0      |                            |             |
|                                      | BL-R2136   | GaP/GaP / Green          | 568                      | Green Diffused  | 30                       | 80      | 30      | 150       | 2.2                           | 2.6 | 4.0      |                            |             |
|                                      | BL-R3136   | GaAsP/GaP/ Yellow        | 585                      |                 | Yellow Diffused          | 35      | 80      | 30        | 150                           | 2.1 | 2.6      |                            |             |
|                                      | BL-R4136   | GaAsP/GaP/ Orange        | 635                      | Orange Diffused | 25                       | 80      | 30      | 150       | 2.0                           | 2.6 | 4.0      |                            |             |
|                                      | BL-R9136   | GaP/GaP/ Pure Green      | 555                      | Green Diffused  | 30                       | 80      | 30      | 150       | 2.2                           | 2.6 | 0.4      |                            |             |
| 187x5.7x 6.8mm 1.0" Lead Rectangular | BL-R1136A  | GaAsP/GaAs/ Red          | 655                      | Red Diffused    | 40                       | 80      | 40      | 200       | 1.7                           | 2.0 | 0.4      | 120                        | L-094       |
|                                      | BL-R5136A  | GaP/GaP/ Bright Red      | 700                      |                 | 90                       | 40      | 15      | 50        | 2.2                           | 2.6 | 0.6      |                            |             |
|                                      | BL-R4536A  | GaAsP/GaP/ Hi-Eff Red    | 635                      |                 | 45                       | 80      | 30      | 150       | 2.0                           | 2.6 | 4.0      |                            |             |
|                                      | BL-R2136A  | GaP/GaP/ Green           | 568                      | Green Diffused  | 30                       | 80      | 30      | 150       | 2.2                           | 2.6 | 4.0      |                            |             |
|                                      | BL-R3136A  | GaAsP/GaP/ Yellow        | 585                      |                 | Yellow Diffused          | 35      | 80      | 30        | 150                           | 2.1 | 2.6      |                            |             |
|                                      | BL-R4136A  | GaAsP/GaP / Orange       | 635                      | Orange Diffused | 25                       | 80      | 30      | 150       | 2.0                           | 2.6 | 4.0      |                            |             |
|                                      | BL-R9136A  | GaP/GaP/Pure Green       | 555                      | Green Diffused  | 30                       | 80      | 30      | 150       | 2.2                           | 2.6 | 0.4      |                            |             |
| 3.0x4.8x 7.0mm 1.0" Lead Rectangular | BL-R1137   | GaAsP/GaAs/ Red          | 655                      | Red Diffused    | 40                       | 80      | 40      | 200       | 1.7                           | 2.0 | 0.4      | 120                        | L-095       |
|                                      | BL-R5137   | GaP/GaP/ Bright Red      | 700                      |                 | 90                       | 40      | 15      | 50        | 2.2                           | 2.6 | 0.6      |                            |             |
|                                      | BL-R4537   | GaAsP/GaP/ Hi-Eff Red    | 635                      |                 | 45                       | 80      | 30      | 150       | 2.0                           | 2.6 | 4.0      |                            |             |
|                                      | BL-R2137   | GaP/GaP / Green          | 568                      | Green Diffused  | 30                       | 80      | 30      | 150       | 2.2                           | 2.6 | 4.0      |                            |             |
|                                      | BL-R3137   | GaAsP/GaP/ Yellow        | 585                      |                 | Yellow Diffused          | 35      | 80      | 30        | 150                           | 2.1 | 2.6      |                            |             |
|                                      | BL-R4137   | GaAsP/GaP/ Orange        | 635                      | Orange Diffused | 25                       | 80      | 30      | 150       | 2.0                           | 2.6 | 4.0      |                            |             |
| 1.8x5.2 8.0mm 1.0" Lead Rectangular  | BL-R1138   | GaAsP/GaAs/ Red          | 655                      | Red Diffused    | 40                       | 80      | 40      | 200       | 1.7                           | 2.0 | 0.6      | 120                        | L-096       |
|                                      | BL-R5138   | GaP/GaP/ Bright Red      | 700                      |                 | 90                       | 40      | 15      | 50        | 2.2                           | 2.6 | 1.0      |                            |             |
|                                      | BL-R4538   | GaAsP/GaP/ Hi-Eff Red    | 635                      |                 | 45                       | 80      | 30      | 150       | 2.0                           | 2.6 | 7.0      |                            |             |
|                                      | BL-R2138   | GaP/GaP / Green          | 568                      | Green Diffused  | 30                       | 80      | 30      | 150       | 2.2                           | 2.6 | 7.0      |                            |             |
|                                      | BL-R3138   | GaAsP/GaP/ Yellow        | 585                      |                 | Yellow Diffused          | 35      | 80      | 30        | 150                           | 2.1 | 2.6      |                            |             |

Remark : 1.Hi-Eff Red / High-Efficiency Red.  
 2.Trans / Transparent.  
 3.2θ 1/2 The off-axis angle at which the luminous intensity is half the axial luminous intensity.

| L-089 BL-Rxx15 Series   | L-090 BL-Rxx35 Series  |
|---|--|
|    |    |
| L-091 BL-Rxx35A Series  | L-092 BL-Rxx35B Series   |
|   |   |
| L-093 BL-Rxx36 Series   | L-094 BL-Rxx36A Series   |
|  |  |
| L-095 BL-Rxx37 Series   | L-096 BL-Rxx38 Series  |
|  |  |

Notes : 1.All Dimensions are in millimeters (inches).  
2.Tolerance is  $\pm 0.25\text{mm}$  (.010").