

SM-8 DUAL NPN MEDIUM POWER DARLINGTON TRANSISTORS

ISSUE 1 - NOVEMBER 1995

ZDT605

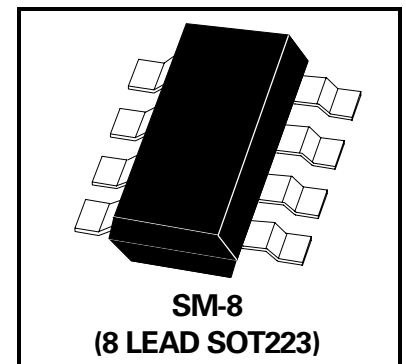
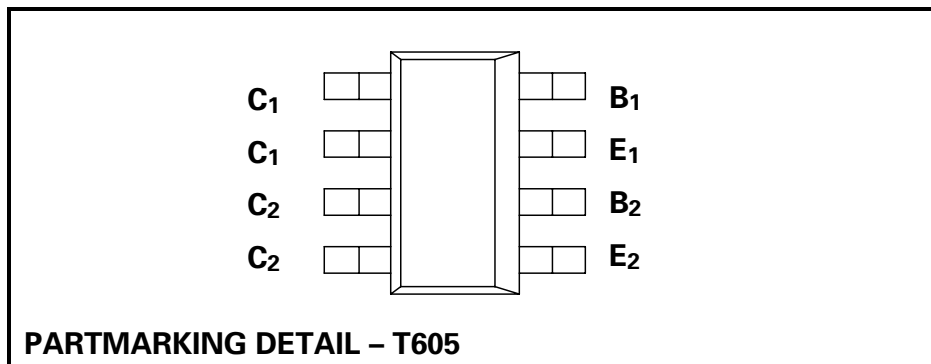

ABSOLUTE MAXIMUM RATINGS.

PARAMETER	SYMBOL	VALUE	UNIT
Collector-Base Voltage	V_{CBO}	140	V
Collector-Emitter Voltage	V_{CEO}	120	V
Emitter-Base Voltage	V_{EBO}	10	V
Peak Pulse Current	I_{CM}	4	A
Continuous Collector Current	I_C	1	A
Operating and Storage Temperature Range	$T_j; T_{stg}$	-55 to +150	°C

THERMAL CHARACTERISTICS

PARAMETER	SYMBOL	VALUE	UNIT
Total Power Dissipation at $T_{amb} = 25^\circ\text{C}^*$ Any single die "on" Both die "on" equally	P_{tot}	2.25 2.75	W W
Derate above 25°C^* Any single die "on" Both die "on" equally		18 22	mW/°C mW/°C
Thermal Resistance - Junction to Ambient* Any single die "on" Both die "on" equally		55.6 45.5	°C/W °C/W

* The power which can be dissipated assuming the device is mounted in a typical manner on a PCB with copper equal to 2 inches square.

ZDT605

ELECTRICAL CHARACTERISTICS (at $T_{amb} = 25^{\circ}\text{C}$ unless otherwise stated).

PARAMETER	SYMBOL	MIN.	MAX.	UNIT	CONDITIONS.
Collector-Base Breakdown Voltage	$V_{(BR)CBO}$	140		V	$I_C=100\mu\text{A}$
Collector-Emitter Breakdown Voltage	$V_{CEO(SUS)}$	120		V	$I_C=10\text{mA}^*$
Emitter-Base Breakdown Voltage	$V_{(BR)EBO}$	10		V	$I_E=100\mu\text{A}$
Collector Cutoff Current	I_{CBO}		0.01 10	μA μA	$V_{CB}=120\text{V}$ $V_{CB}=120\text{V}, T_{amb}=100^{\circ}\text{C}$
Collector Cutoff Current	I_{CES}		10	μA	$V_{CES}=120\text{V}$
Emitter Cutoff Current	I_{EBO}		0.1	μA	$V_{EB}=8\text{V}$
Collector-Emitter Saturation Voltage	$V_{CE(sat)}$		1.0 1.5	V V	$I_C=250\text{mA}, I_B=0.25\text{mA}^*$ $I_C=1\text{A}, I_B=1\text{mA}^*$
Base-Emitter Saturation Voltage	$V_{BE(sat)}$		1.8	V	$I_C=1\text{A}, I_B=1\text{mA}^*$
Base-Emitter TurnOn Voltage	$V_{BE(on)}$		1.7	V	$I_C=1\text{A}, V_{CE}=5\text{V}^*$
Static Forward Current Transfer Ratio	h_{FE}	2K 5K 2K 0.5K	100K		$I_C=50\text{mA}, V_{CE}=5\text{V}^*$ $I_C=500\text{mA}, V_{CE}=5\text{V}^*$ $I_C=1\text{A}, V_{CE}=5\text{V}^*$ $I_C=2\text{A}, V_{CE}=5\text{V}^*$
Transition Frequency	f_T	150		MHz	$I_C=100\text{mA}, V_{CE}=10\text{V}$ $f=20\text{MHz}$
Input Capacitance	C_{ibo}	90 Typical		pF	$V_{EB}=0.5\text{V}, f=1\text{MHz}$
Output Capacitance	C_{obo}	15 Typical		pF	$V_{CE}=10\text{V}, f=1\text{MHz}$
Switching Times	t_{on}	0.5 Typical		μs	$I_C=0.5\text{A}, V_{CE}=10\text{V}$ $I_{B1}=I_{B2}=0.5\text{mA}$
	t_{off}	1.6 Typical		μs	

*Measured under pulsed conditions. Pulse width=300 μs . Duty cycle $\leq 2\%$

ZDT605

TYPICAL CHARACTERISTICS

