

# Z86E02 SL1925

## CMOS Z8® OTP MICROCONTROLLER

### FEATURES

Part Number	ROM (Kilobytes)	RAM* (Bytes)	Speed (MHz)
Z86E02	0.5	61	8

\* General-Purpose

- 18-Pin DIP and SOIC Packages
- 3.5V to 5.5V Operating Range @ 0°C to +70°C  
4.5V to 5.5V Operating Range @ -40°C to +105°C
- 14 Input / Output Lines
- Five Vectored, Prioritized Interrupts with Programmable Polarity
- Two Analog Comparators
- WDT/Power-On Reset (POR)

- Program Options:
  - Low Noise
  - ROM Protect
  - Auto Latch
  - Permanent Watch-Dog Timer (WDT)
  - EPROM/TEST Mode Disable
  - RC Oscillator
- One Programmable 8-Bit Counter/Timer, with 6-Bit Programmable Prescaler
- On-Chip Oscillator that Accepts RC, XTAL, Ceramic Resonance, LC, or External Clock
- Clock-Free WDT Reset
- Low-Power Consumption (50 mw)
- Fast Instruction Pointer (1.5  $\mu$ s @ 8 MHz)

### GENERAL DESCRIPTION

Zilog's Z86E02 Microcontroller (MCU) is a One-Time Programmable (OTP) member of the Z8 single-chip microcontroller family which allow easy software development, debug, prototyping, and small production runs not economically desirable with masked ROM versions.

For applications demanding powerful I/O capabilities, the Z86E02's dedicated input and output lines are grouped into three ports, and are configurable under software control to provide timing, status signals, or parallel I/O.

An on-chip counter/timer, with a large number of user selectable modes, offload the system of administering real-time tasks such as counting/timing and I/O data communications.

**Note:** All Signals with a preceding front slash, "/", are active Low, e.g.: B//W (WORD is active Low); /B/W (BYTE is active Low, only).

Power connections follow conventional descriptions below:

Connection	Circuit	Device
Power	V <sub>CC</sub>	V <sub>DD</sub>
Ground	GND	V <sub>SS</sub>

GENERAL DESCRIPTION (Continued)

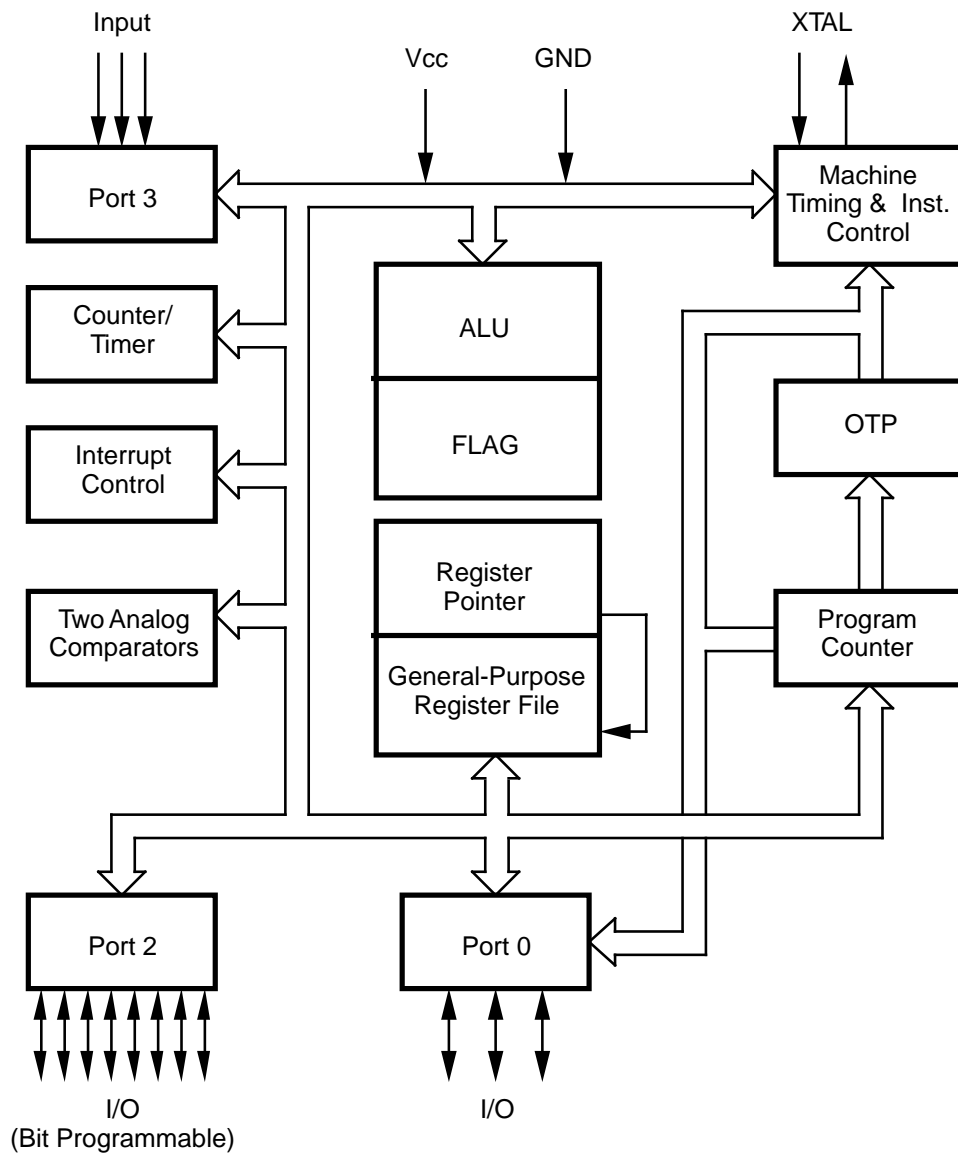

Figure 1. Functional Block Diagram

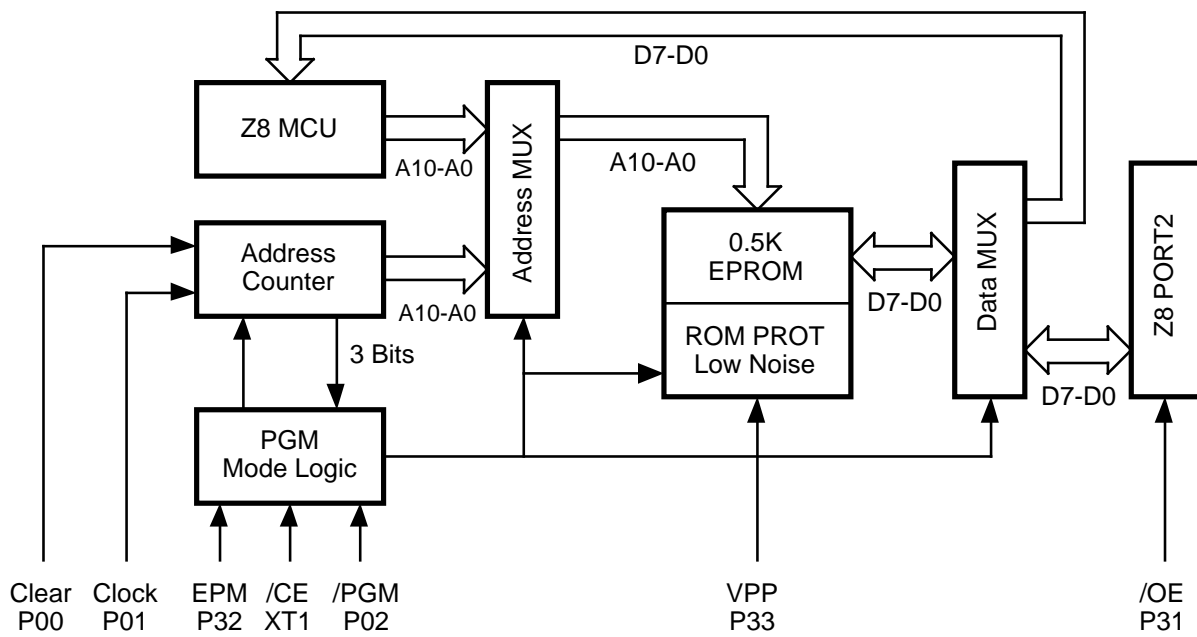
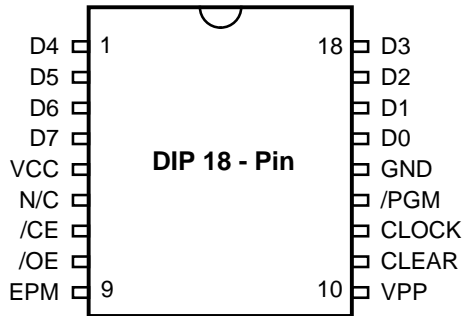

Figure 2. EPROM Programming Mode Block Diagram

**PIN DESCRIPTION**



**Figure 3. 18-Pin EPROM Mode Configuration**

**Table 1. 18-Pin DIP Pin Identification**

EPROM Programming Mode			
Pin #	Symbol	Function	Direction
1–4	D4–D7	Data 4, 5, 6, 7	In/Output
5	V <sub>CC</sub>	Power Supply	
6	N/C	No Connection	
7	/CE	Chip Enable	Input
8	/OE	Output Enable	Input
9	EPM	EPROM Prog Mode	Input
10	V <sub>PP</sub>	Prog Voltage	Input
11	Clear	Clear Clock	Input
12	Clock	Address	Input
13	/PGM	Prog Mode	Input
14	GND	Ground	
15–18	D3–D0	Data 0,1, 2, 3	In/Output

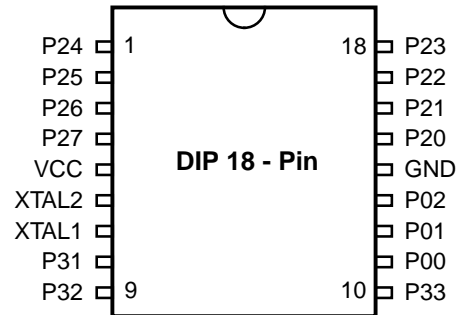

**Figure 4. 18-Pin DIP/SOIC Standard Mode Configuration**

**Table 2. 18-Pin DIP/SOIC Pin Identification**

Standard Mode			
Pin #	Symbol	Function	Direction
1–4	P24–P27	Port 2, Pins 4,5,6,7	In/Output
5	V <sub>cc</sub>	Power Supply	
6	XTAL2	Crystal Osc. Clock	Output
7	XTAL1	Crystal Osc. Clock	Input
8	P31	Port 3, Pin 1, AN1	Input
9	P32	Port 3, Pin 2, AN2	Input
10	P33	Port 3, Pin 3, REF	Input
11–13	P00–P02	Port 0, Pins 0,1,2	In/Output
14	GND	Ground	
15–18	P20–P23	Port 2, Pins 0,1,2,3	In/Output

## ABSOLUTE MAXIMUM RATINGS

Stresses greater than those listed under Absolute Maximum Ratings may cause permanent damage to the device. This is a stress rating only; functional operation of the device at any condition above those indicated in the operational sections of these specifications is not implied. Exposure to absolute maximum rating conditions for an extended period may affect device reliability. Total power

dissipation should not exceed 462 mW for the package. Power dissipation is calculated as follows:

$$\begin{aligned} \text{Total Power Dissipation} = & V_{DD} \times [I_{DD} - (\text{sum of } I_{OH})] \\ & + \text{sum of } [(V_{DD} - V_{OH}) \times I_{OH}] \\ & + \text{sum of } (V_{OL} \times I_{OL}) \end{aligned}$$

Parameter	Min	Max	Units	Note
Ambient Temperature under Bias	-40	+105	C	
Storage Temperature	-65	+150	C	
Voltage on any Pin with Respect to $V_{SS}$	-0.7	+12	V	1
Voltage on $V_{DD}$ Pin with Respect to $V_{SS}$	-0.3	+7	V	
Voltage on Pins 7, 8, 9, 10 with Respect to $V_{SS}$	-0.6	$V_{DD}+1$	V	2
Total Power Dissipation		462	mW	
Maximum Allowable Current out of $V_{SS}$		240	mA	
Maximum Allowable Current into $V_{DD}$		240	mA	
Maximum Allowable Current into an Input Pin	-600	+600	$\mu\text{A}$	3
Maximum Allowable Current into an Open-Drain Pin	-600	+600	$\mu\text{A}$	4
Maximum Allowable Output Current Sunked by Any I/O Pin		20	mA	
Maximum Allowable Output Current Sourced by Any I/O Pin		20	mA	

### Notes:

- [1] This applies to all pins except where otherwise noted. Maximum current into pin must be  $\pm 600 \mu\text{A}$ .  
 [2] There is no input protection diode from pin to  $V_{SS}$  (not applicable to EPROM Mode).  
 [3] This excludes Pin 6 and Pin 7.  
 [4] Device pin is not at an output Low state.

## STANDARD TEST CONDITIONS

The characteristics listed below apply for standard test conditions as noted. All voltages are referenced to Ground. Positive current flows into the referenced pin (Figure 5).

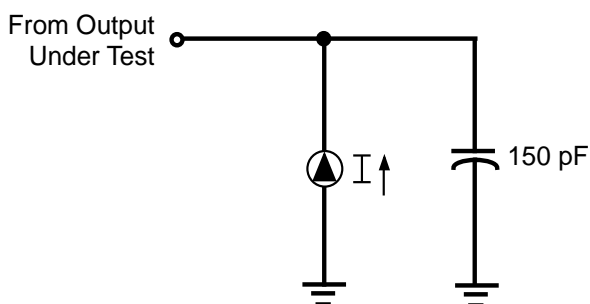

Figure 5. Test Load Diagram

## CAPACITANCE

$T_A = 25^\circ\text{C}$ ,  $V_{CC} = \text{GND} = 0\text{V}$ ,  $f = 1.0\text{ MHz}$ , unmeasured pins returned to GND.

Parameter	Min	Max
Input capacitance	0	10 pF
Output capacitance	0	20 pF
I/O capacitance	0	25 pF

## DC ELECTRICAL CHARACTERISTICS

Sym	Parameter	$V_{CC}$ [4]	$T_A = 0^\circ\text{C to } +70^\circ\text{C}$		Typical Note 4 @ $25^\circ\text{C}$	Units	Conditions	Notes
			Min	Max				
$V_{inmax}$	Max Input Voltage	3.5V		12		V	$I_{in} < 250\ \mu\text{A}$	1
		5.5V		12		V	$I_{in} < 250\ \mu\text{A}$	1
$V_{CH}$	Clock Input High Voltage	3.5V	$0.8 V_{CC}$	$V_{CC} + 0.3$	1.7	V	Driven by External Clock Generator	
		5.5V	$0.8 V_{CC}$	$V_{CC} + 0.3$	2.8	V	Driven by External Clock Generator	
$V_{CL}$	Clock Input Low Voltage	3.5V	$V_{SS} - 0.3$	$0.2 V_{CC}$	0.8	V	Driven by External Clock Generator	
		5.5V	$V_{SS} - 0.3$	$0.2 V_{CC}$	1.7	V	Driven by External Clock Generator	
$V_{IH}$	Input High Voltage	3.5V	$0.7 V_{CC}$	$V_{CC} + 0.3$	1.8	V		
		5.5V	$0.7 V_{CC}$	$V_{CC} + 0.3$	2.8	V		
$V_{IL}$	Input Low Voltage	3.5V	$V_{SS} - 0.3$	$0.2 V_{CC}$	0.8	V		
		5.5V	$V_{SS} - 0.3$	$0.2 V_{CC}$	1.5	V		
$V_{OH}$	Output High Voltage	3.5V	$V_{CC} - 0.4$		3.0	V	$I_{OH} = -2.0\ \text{mA}$	5
		5.5V	$V_{CC} - 0.4$		4.8	V	$I_{OH} = -2.0\ \text{mA}$	5
		3.5V	$V_{CC} - 0.4$		3.0	V	Low Noise @ $I_{OH} = -0.5\ \text{mA}$	
		5.5V	$V_{CC} - 0.4$		4.8	V	Low Noise @ $I_{OH} = -0.5\ \text{mA}$	
$V_{OL1}$	Output Low Voltage	3.5V		0.8	0.2	V	$I_{OL} = +4.0\ \text{mA}$	5
		5.5V		0.4	0.1	V	$I_{OL} = +4.0\ \text{mA}$	5
		3.5V		0.4	0.2	V	Low Noise @ $I_{OL} = 1.0\ \text{mA}$	
		5.5V		0.4	0.1	V	Low Noise @ $I_{OL} = 1.0\ \text{mA}$	
$V_{OL2}$	Output Low Voltage	3.5V		1.2	1.0	V	$I_{OL} = +10\ \text{mA}$ ,	5
		5.5V		1.2	0.8	V	$I_{OL} = +10\ \text{mA}$ ,	5
$V_{OFFSET}$	Comparator Input Offset Voltage	3.5V		25.0	10.0	mV		
		5.5V		25.0	10.0	mV		
$V_{LV}$	$V_{CC}$ Low Voltage Protection		2.6	3.2	2.9	V	@ 4 MHz Max. Int. CLK Freq.	
$I_{IL}$	Input Leakage (Input Bias Current of Comparator)	3.5V	-1.0	1.0		$\mu\text{A}$	$V_{IN} = 0\text{V}$ , $V_{CC}$	
		5.5V	-1.0	1.0		$\mu\text{A}$	$V_{IN} = 0\text{V}$ , $V_{CC}$	

Sym	Parameter	V <sub>CC</sub> [4]	T <sub>A</sub> = 0°C to +70°C		Typical Note 4 @ 25°C	Units	Conditions	Notes
			Min	Max				
I <sub>OL</sub>	Output Leakage	3.5V	-1.0	1.0		μA	V <sub>IN</sub> = 0V, V <sub>CC</sub>	
		5.5V	-1.0	1.0		μA	V <sub>IN</sub> = 0V, V <sub>CC</sub>	
V <sub>VICR</sub>	Comparator Input Common Mode Voltage Range		V <sub>SS</sub> -0.3	V <sub>CC</sub> -1.0		V		
I <sub>CC</sub>	Supply Current	3.5V		3.5	1.5	mA	All Output and I/O Pins Floating @ 2 MHz	5,7
		5.5V		7.0	6.8	mA	All Output and I/O Pins Floating @ 2 MHz	5,7
		3.5V		8.0	3.0	mA	All Output and I/O Pins Floating @ 8 MHz	5,7
		5.5V		11.0	8.2	mA	All Output and I/O Pins Floating @ 8 MHz	5,7
I <sub>CC1</sub>	Standby Current	3.5V		2.5	0.7	mA	HALT mode V <sub>IN</sub> = 0V, V <sub>CC</sub> @ 2 MHz	5,7
		5.5V		4.0	2.5	mA	HALT mode V <sub>IN</sub> = 0V, V <sub>CC</sub> @ 2 MHz	5,7
		3.5V		4.0	1.0	mA	HALT mode V <sub>IN</sub> = 0V, V <sub>CC</sub> @ 8 MHz	5,7
		5.5V		5.0	3.0	mA	HALT mode V <sub>IN</sub> = 0V, V <sub>CC</sub> @ 8 MHz	5,7
CC	Supply Current (Low Noise Mode)	3.5V		3.5	1.5	mA	All Output and I/O Pins Floating @ 1 MHz	7
		5.5V		7.0	6.8	mA	All Output and I/O Pins Floating @ 1 MHz	7
CC	Supply Current (Low Noise Mode)	3.5V		5.8	2.5	mA	All Output and I/O Pins Floating @ 2 MHz	7
		5.5V		9.0	7.5	mA	All Output and I/O Pins Floating @ 2 MHz	7
		3.5V		8.0	3.0	mA	All Output and I/O Pins Floating @ 4 MHz	7
		5.5V		11.0	8.2	mA	All Output and I/O Pins Floating @ 4 MHz	7

DC ELECTRICAL CHARACTERISTICS (Continued)

Sym	Parameter	V <sub>CC</sub> [4]	T <sub>A</sub> = 0°C to +70°C		Typical Note 4 @ 25°C	Units	Conditions	Notes
			Min	Max				
I <sub>CC1</sub>	Standby Current (Low Noise Mode)	3.5V		1.2	0.4	mA	HALT mode V <sub>IN</sub> = 0V, V <sub>CC</sub> @ 1 MHz	7
		5.5V		1.6	0.9	mA	HALT mode V <sub>IN</sub> = 0V, V <sub>CC</sub> @ 1 MHz	7
		3.5V		1.5	0.5	mA	HALT mode V <sub>IN</sub> = 0V, V <sub>CC</sub> @ 2 MHz	7
		5.5V		1.9	1.0	mA	HALT mode V <sub>IN</sub> = 0V, V <sub>CC</sub> @ 2 MHz	7
		3.5V		2.0	0.8	mA	HALT mode V <sub>IN</sub> = 0V, V <sub>CC</sub> @ 4 MHz	7
		5.5V		2.4	0.3	mA	HALT mode V <sub>IN</sub> = 0V, V <sub>CC</sub> @ 4 MHz	7
I <sub>CC2</sub>	Standby Current	3.5V		10.0	1.0	μA	STOP mode V <sub>IN</sub> = 0V, V <sub>CC</sub> WDT is not Running	7,8
		5.5V		10.0	1.0	μA	STOP mode V <sub>IN</sub> = 0V, V <sub>CC</sub> WDT is not Running	7,8
I <sub>ALL</sub>	Auto Latch Low Current	3.5V		12.0	3.0	μA	0V < V <sub>IN</sub> < V <sub>CC</sub>	6
		5.5V		32	16	μA	0V < V <sub>IN</sub> < V <sub>CC</sub>	6
I <sub>ALH</sub>	Auto Latch High Current	3.5V		-8.0	-1.5	μA	0V < V <sub>IN</sub> < V <sub>CC</sub>	6
		5.5V		-16.0	-8.0	μA	0V < V <sub>IN</sub> < V <sub>CC</sub>	6

Notes:

1. Port 2 and Port 0 only.
2. V<sub>SS</sub> = 0V = GND.
3. The device operates down to V<sub>RST</sub> of the specified frequency for V<sub>RST</sub>. The minimum operational V<sub>CC</sub> is determined on the value of the voltage V<sub>RST</sub> at the ambient temperature. The V<sub>RST</sub> increases as the temperature decreases.
4. V<sub>CC</sub> = 4.5V to 5.5V, typical values measured at V<sub>CC</sub> = 5.0V.
5. Standard Mode (not Low EMI mode).
6. Autolatches are enabled.
7. All outputs unloaded and all inputs are at V<sub>CC</sub> or V<sub>SS</sub> level.
8. If analog comparator is selected, then the comparator inputs must be at V<sub>CC</sub> level.



Sym	Parameter	V <sub>CC</sub> [4]	T <sub>A</sub> = -40°C to +105°C		Typical Note 4 @ 25°C	Units	Conditions	Notes
			Min	Max				
	Max Input Voltage	4.5V		12.0		V	I <sub>IN</sub> < 250 μA	1
		5.5V		12.0		V	I <sub>IN</sub> < 250 μA	1
V <sub>CH</sub>	Clock Input High Voltage	4.5V	0.8 V <sub>CC</sub>	V <sub>CC</sub> +0.3	2.8	V	Driven by External Clock Generator	
		5.5V	0.8 V <sub>CC</sub>	V <sub>CC</sub> +0.3	2.8	V	Driven by External Clock Generator	
V <sub>CL</sub>	Clock Input Low Voltage	4.5V	V <sub>SS</sub> -0.3	0.2 V <sub>CC</sub>	1.7	V	Driven by External Clock Generator	
		5.5V	V <sub>SS</sub> -0.3	0.2 V <sub>CC</sub>	1.7	V	Driven by External Clock Generator	
V <sub>IH</sub>	Input High Voltage	4.5V	0.7 V <sub>CC</sub>	V <sub>CC</sub> +0.3	2.8	V		
		5.5V	0.7 V <sub>CC</sub>	V <sub>CC</sub> +0.3	2.8	V		
V <sub>IL</sub>	Input Low Voltage	4.5V	V <sub>SS</sub> -0.3	0.2 V <sub>CC</sub>	1.5	V		
		5.5V	V <sub>SS</sub> -0.3	0.2 V <sub>CC</sub>	1.5	V		
V <sub>OH</sub>	Output High Voltage	4.5V	V <sub>CC</sub> -0.4		4.8	V	I <sub>OH</sub> = -2.0 mA	5
		5.5V	V <sub>CC</sub> -0.4		4.8	V	I <sub>OH</sub> = -2.0 mA	5
		4.5V	V <sub>CC</sub> -0.4			V	Low Noise @ I <sub>OH</sub> = -0.5 mA	
		5.5V	V <sub>CC</sub> -0.4			V	Low Noise @ I <sub>OH</sub> = -0.5 mA	
V <sub>OL1</sub>	Output Low Voltage	4.5V		0.8	0.1	V	I <sub>OL</sub> = +4.0 mA	5
		5.5V		0.4	0.1	V	I <sub>OL</sub> = +4.0 mA	5
		4.5V		0.4	0.1	V	Low Noise @ I <sub>OL</sub> = 1.0 mA	
		5.5V		0.4	0.1	V	Low Noise @ I <sub>OL</sub> = 1.0 mA	
V <sub>OL2</sub>	Output Low Voltage	4.5V		1.2	1.0	V	I <sub>OL</sub> = +10 mA,	5
		5.5V		1.2	0.8	V	I <sub>OL</sub> = +10 mA,	5
V <sub>OFFSET</sub>	Comparator Input Offset Voltage	4.5V		25.0	10.0	mV		
		5.5V		25.0	10.0	mV		
V <sub>LV</sub>	V <sub>CC</sub> Low Voltage Protection		2.3	3.5	2.9	V	@ 4 MHz Max. Int. CLK Freq.	3
I <sub>IL</sub>	Input Leakage (Input Bias Current of Comparator)	4.5V		-1.0	1.0	μA	V <sub>IN</sub> = 0V, V <sub>CC</sub>	
		5.5V		-1.0	1.0	μA	V <sub>IN</sub> = 0V, V <sub>CC</sub>	
I <sub>OL</sub>	Output Leakage	4.5V		-1.0	1.0	μA	V <sub>IN</sub> = 0V, V <sub>CC</sub>	
		5.5V		-1.0	1.0	μA	V <sub>IN</sub> = 0V, V <sub>CC</sub>	
V <sub>VICR</sub>	Comparator Input Common Mode Voltage Range		V <sub>SS</sub> -0.3	V <sub>CC</sub> -1.5		V		
I <sub>CC</sub>	Supply Current	4.5V		7.0	6.8	mA	All Output and I/O Pins Floating @ 2 MHz	5,7
		5.5V		7.0	6.8	mA	All Output and I/O Pins Floating @ 2 MHz	5,7
		4.5V		11.0	8.2	mA	All Output and I/O Pins Floating @ 8 MHz	5,7
		5.5V		11.0	8.2	mA	All Output and I/O Pins Floating @ 8 MHz	5,7

**DC ELECTRICAL CHARACTERISTICS** (Continued)

Sym	Parameter	V <sub>CC</sub> [4]	T <sub>A</sub> = -40°C to +105°C		Typical Note 4 @ 25°C	Units	Conditions	Notes
			Min	Max				
I <sub>CC1</sub>	Standby Current	4.5V		3.0	2.5	mA	HALT mode V <sub>IN</sub> = 0V, V <sub>CC</sub> @ 2 MHz	5,7
		5.5V		3.0	2.5	mA	HALT mode V <sub>IN</sub> = 0V, V <sub>CC</sub> @ 2 MHz	5,7
		4.5V		5.0	3.0	mA	HALT mode V <sub>IN</sub> = 0V, V <sub>CC</sub> @ 8 MHz	5,7
		5.5V		5.0	3.0	mA	HALT mode V <sub>IN</sub> = 0V, V <sub>CC</sub> @ 8 MHz	5,7
I <sub>CC</sub>	Supply Current (Low Noise Mode)	4.5V		7.0	6.8	mA	All Output and I/O Pins Floating @ 1 MHz	7
		5.5V		7.0	6.8	mA	All Output and I/O Pins Floating @ 1 MHz	7
		4.5V		9.0	7.5	mA	All Output and I/O Pins Floating @ 2 MHz	7
		5.5V		9.0	7.5	mA	All Output and I/O Pins Floating @ 2 MHz	7
		4.5V		11.0	8.2	mA	All Output and I/O Pins Floating @ 4 MHz	7
		5.5V		11.0	8.2	mA	All Output and I/O Pins Floating @ 4 MHz	7

Sym	Parameter	V <sub>CC</sub> [4]	T <sub>A</sub> = -40°C to +105°C		Typical Note 4 @ 25°C	Units	Conditions	Notes
			Min	Max				
I <sub>CC1</sub>	Standby Current (Low Noise Mode)	4.5V		1.6	0.9	mA	HALT mode V <sub>IN</sub> = 0V, V <sub>CC</sub> @ 1 MHz	7
		5.5V		1.6	0.9	mA	HALT mode V <sub>IN</sub> = 0V, V <sub>CC</sub> @ 1 MHz	7
		4.5V		1.9	1	mA	HALT mode V <sub>IN</sub> = 0V, V <sub>CC</sub> @ 2 MHz	7
		5.5V		1.9	1	mA	HALT mode V <sub>IN</sub> = 0V, V <sub>CC</sub> @ 2 MHz	7
I <sub>CC2</sub>	Standby Current	4.5V		20	1.0	μA	STOP mode V <sub>IN</sub> = 0V, V <sub>CC</sub> WDT is not Running	7,8
		5.5V		20	1.0	μA	STOP mode V <sub>IN</sub> = 0V, V <sub>CC</sub> WDT is not Running	7,8
ALL	Auto Latch Low Current	4.5V		40	16	μA	0V < V <sub>IN</sub> < V <sub>CC</sub>	6
		5.5V		40	16	μA	0V < V <sub>IN</sub> < V <sub>CC</sub>	6
I <sub>ALH</sub>	Auto Latch High Current	4.5V		-20.0	-8.0	μA	0V < V <sub>IN</sub> < V <sub>CC</sub>	6
		5.5V		-20.0	-8.0	μA	0V < V <sub>IN</sub> < V <sub>CC</sub>	6

**Notes:**

- Port 2 and Port 0 only.
- V<sub>SS</sub> = 0V = GND.
- The device operates down to V<sub>RST</sub> of the specified frequency for V<sub>RST</sub>. The minimum operational V<sub>CC</sub> is determined on the value of the voltage V<sub>RST</sub> at the ambient temperature. The V<sub>RST</sub> increases as the temperature decreases.
- V<sub>CC</sub> = 4.5V to 5.5V, typical values measured at V<sub>CC</sub> = 5.0V.
- Standard Mode (not Low EMI mode).
- Autolatches are enabled.
- All outputs unloaded and all inputs are at V<sub>CC</sub> or V<sub>SS</sub> level.
- If analog comparator is selected, then the comparator inputs must be at V<sub>CC</sub> level.

AC ELECTRICAL CHARACTERISTICS

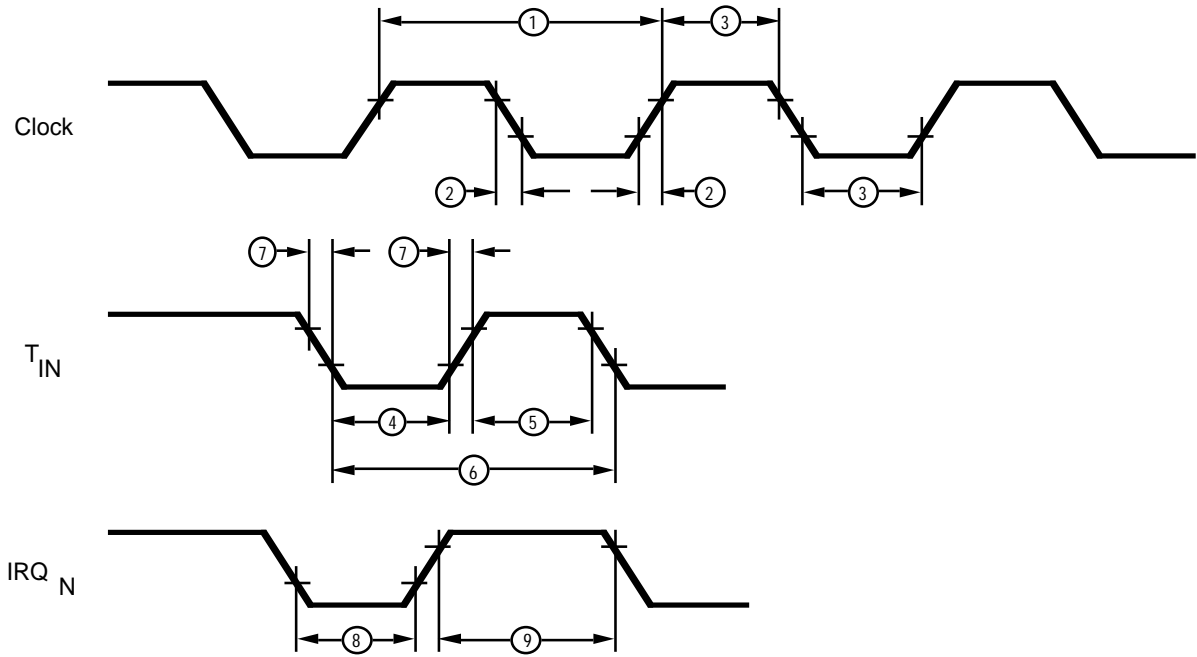

Figure 6. AC Electrical Timing Diagram

**AC ELECTRICAL CHARACTERISTICS**

Timing Table (Standard Mode for SCLK/TCLK = XTAL/2)

$T_A = 0^\circ\text{C to } +70^\circ\text{C}$							
8 MHz							
No	Symbol	Parameter	$V_{CC}$	Min	Max	Units	Notes
1	TpC	Input Clock Period	3.5V	125	DC	ns	1
			5.5V	125	DC	ns	1
2	TrC,TfC	Clock Input Rise and Fall Times	3.5V		25	ns	1
			5.5V		25	ns	
3	TwC	Input Clock Width	3.5V	62		ns	1
			5.5V	62		ns	1
4	TwTinL	Timer Input Low Width	3.5V	100		ns	[
			5.5V	70		ns	1
5	TwTinH	Timer Input High Width	3.5V	5TpC			1
			5.5V	5TpC			1
6	TpTin	Timer Input Period	3.5V		8TpC		1
			5.5V		8TpC		[
7	TrTin, TtTin	Timer Input Rise and Fall Time	3.5V		100	ns	1
			5.5V		100	ns	1
8	TwlL	Int. Request Input Low Time	3.5V	100		ns	1,2
			5.5V	70		ns	1,2
9	TwhH	Int. Request Input High Time	3.5V		5TpC		1
			5.5V		5TpC		1,2
10	Twdt	Watch-Dog Timer Delay Time for Timeout	3.5V	10		ms	1
			5.5V	5		ms	1
11	Tpor	Power-On Reset Time	3.5V	4	36	ms	1
			5.5V	2	18	ms	1

**Notes:**

1. Timing Reference uses 0.7  $V_{CC}$  for a logic 1 and 0.2  $V_{CC}$  for a logic 0.
2. Interrupt request through Port 3 (P33-P31).

## AC ELECTRICAL CHARACTERISTICS

Timing Table (Standard Mode for SCLK/TCLK = XTAL/2)

$T_A = -40^{\circ}\text{C to } +105^{\circ}\text{C}$ 8 MHz							
No	Symbol	Parameter	$V_{CC}$	Min	Max	Units	Notes
1	TpC	Input Clock Period	4.5V	125	DC	ns	1
			5.5V	125	DC	ns	1
2	TrC,TfC	Clock Input Rise and Fall Times	4.5V		25	ns	1
			5.5V		25	ns	
3	TwC	Input Clock Width	4.5V		62	ns	1
			5.5V		62	ns	1
4	TwTinL	Timer Input Low Width	4.5V	70		ns	1
			5.5V	70		ns	1
5	TwTinH	Timer Input High Width	4.5V	5TpC			1
			5.5V	5TpC			1
6	TpTin	Timer Input Period	4.5V	8TpC			1
			5.5V	8TpC			1
7	TrTin, TtTin	Timer Input Rise and Fall Timer	4.5V		100	ns	1
			5.5V		100	ns	1
8	TwIL	Int. Request Input Low Time	4.5V	70		ns	1,2
			5.5V	70		ns	1,2
9	TwIH	Int. Request Input High Time	4.5V	5TpC			1
			5.5V	5TpC			1,2
10	Twdt	Watch-Dog Timer Delay Time for Timeout	4.5V	5		ms	1
			5.5V	5		ms	1
11	Tpor	Power-On Reset Time	4.5V	2	20	ms	1
			5.5V	2	20	ms	1

**Notes:**

1. Timing Reference uses 0.7  $V_{CC}$  for a logic 1 and 0.2  $V_{CC}$  for a logic 0.
2. Interrupt request through Port 3 (P33-P31).

**AC ELECTRICAL CHARACTERISTICS**

## Low Noise Mode

No	Symbol	Parameter	V <sub>CC</sub>	T <sub>A</sub> = 0°C to +70°C				Units	Notes
				1 MHz		4 MHz			
				Min	Max	Min	Max		
1	TPC	Input Clock Period	3.5V	1000	DC	250	DC	ns	1
			5.5V	1000	DC	250	DC	ns	1
2	TrC TfC	Clock Input Rise and Fall Times	3.5V		25		25	ns	1
			5.5V		25		25	ns	1
3	TwC	Input Clock Width	3.5V	500		125		ns	1
			5.5V	500		125		ns	1
4.	TwTinL	Timer Input Low Width	3.5V	100		100		ns	1
			5.5V	70		70		ns	1
5	TwTinH	Timer Input High Width	3.5V	2.5TpC		2.5TpC			1
			5.5V	2.5TpC		2.5TpC			1
6	TpTin	Timer Input Period	3.5V	4TpC		4TpC			1
			5.5V	4TpC		4TpC			1
7	TrTin, TtTin	Timer Input Rise and Fall Timer	3.5V		100		100	ns	1
			5.5V		100		100	ns	1
8	TwlL Low Time	Int. Request Input	3.5V	100		100		ns	1,2
			5.5V	70		70		ns	1,2
9	TwhH High Time	Int. Request Input	3.5V	2.5TpC		2.5TpC			1
			5.5V	2.5TpC		2.5TpC			1,2
10	Twdt	Watch-Dog Timer Delay Time for Timeout	3.5V	10		10		ms	1
			5.5V	5		5		ms	1

**Notes:**

1. Timing Reference uses 0.7 V<sub>CC</sub> for a logic 1 and 0.2 V<sub>CC</sub> for a logic 0.
2. Interrupt request through Port 3 (P33-P31).

## AC ELECTRICAL CHARACTERISTICS

### Low Noise Mode

No	Symbol	Parameter	V <sub>CC</sub>	T <sub>A</sub> = -40°C to +105°C				Units	Notes
				1 MHz		4 MHz			
				Min	Max	Min	Max		
1	TPC	Input Clock Period	4.5V	1000	DC	250	DC	ns	1
			5.5V	1000	DC	250	DC	ns	1
2	TrC TfC	Clock Input Rise and Fall Times	4.5V		25		25	ns	1
			5.5V		25		25	ns	1
3	TwC	Input Clock Width	4.5V	500		125		ns	1
			5.5V	500		125		ns	1
4.	TwTinL	Timer Input Low Width	4.5V	70		70		ns	1
			5.5V	70		70		ns	1
5	TwTinH	Timer Input High Width	4.5V	2.5TpC		2.5TpC			1
			5.5V	2.5TpC		2.5TpC			1
6	TpTin	Timer Input Period	4.5V		4TpC	4TpC			1
			5.5V		4TpC	4TpC			1
7	TrTin, TtTin	Timer Input Rise and Fall Timer	4.5V		100		100	ns	1
			5.5V		100		100	ns	1
8	TwlL	Int. Request Input Low Time	4.5V	70		70		ns	1,2
			5.5V	70		70		ns	1,2
9	TwhH	Int. Request Input High Time	4.5V	2.5TpC		2.5TpC			1
			5.5V	2.5TpC		2.5TpC			1,2
10	Twdt	Watch-Dog Timer Delay Time for Timeout	4.5V	5		5		ms	1
			5.5V	5		5		ms	1

**Notes:**

1. Timing Reference uses 0.7 V<sub>CC</sub> for a logic 1 and 0.2 V<sub>CC</sub> for a logic 0.
2. Interrupt request through Port 3 (P33-P31).



## LOW NOISE VERSION

### Low EMI Emission

The Z86E02 can be programmed to operate in a Low EMI emission mode by means of a mask ROM bit option. Use of this feature results in:

- All pre-driver slew rates reduced to 10 ns typical.
- Internal SCLK/TCLK operation limited to a maximum of 4 MHz - 250 ns cycle time.

- Output drivers have resistances of 200 ohms (typical).
- Oscillator divide-by-two circuitry eliminated.

The Low EMI mode is mask-programmable to be selected by the customer at the time the ROM code is submitted.

---

© 1997 by Zilog, Inc. All rights reserved. No part of this document may be copied or reproduced in any form or by any means without the prior written consent of Zilog, Inc. The information in this document is subject to change without notice. Devices sold by Zilog, Inc. are covered by warranty and patent indemnification provisions appearing in Zilog, Inc. Terms and Conditions of Sale only. Zilog, Inc. makes no warranty, express, statutory, implied or by description, regarding the information set forth herein or regarding the freedom of the described devices from intellectual property infringement. Zilog, Inc. makes no warranty of merchantability or fitness for any purpose. Zilog, Inc. shall not be responsible for any errors that may appear in this document. Zilog, Inc. makes no commitment to update or keep current the information contained in this document.

Zilog's products are not authorized for use as critical components in life support devices or systems unless a specific written agreement pertaining to such intended use is executed between the customer and Zilog prior to use. Life support devices or systems are those which are intended for surgical implantation into the body, or which sustains life whose failure to perform, when properly used in accordance with instructions for use provided in the labeling, can be reasonably expected to result in significant injury to the user.

Zilog, Inc. 210 East Hacienda Ave.  
Campbell, CA 95008-6600  
Telephone (408) 370-8000  
FAX 408 370-8056  
Internet: <http://www.zilog.com>

